

HELIOS[®]

LED Processing Platform

User Guide

Legal

Copyright © 2020-2026 Megapixel.

The Megapixel® logo is a registered trademark of H2VR HoldCo, Inc. Other trademarks and trade names may be used in this document to refer to products by other entities. Megapixel claims no proprietary interest in trademarks and trade names owned by others.

Information and specifications in this document are subject to change without notice. Megapixel assumes no responsibility or liability for any errors or inaccuracies that may appear in this manual.

Contact

+1 818 884 5488

<https://megapixelvr.com/>



Warranty Information

Megapixel warrants the HELIOS® LED Processing Platform, and other hardware products, against defects in materials and workmanship under normal use for a period of one (1) year from the date of retail purchase by the original end-user purchaser.

Megapixel does not warrant that the operation of the product will be uninterrupted or error free. Megapixel is not responsible for damage arising from failure to follow product or installation instructions.

Safety Information

The symbols below are used in this manual to identify important safety information. Heed all warnings and safety information.

Symbol	Meaning
	Warning, Danger, or Caution Risk of injury to yourself or the product.
	Risk of Electrical Shock Risk of severe electrical shock.



This device contains Electrostatic Sensitive Devices. Wear anti-electrostatic gloves or bracelet when handling the device.



This device passed testing under the condition of being used with professional devices only. It may cause frequency interference when used in a domestic environment.



Signal may become disconnected when electrostatic is induced externally.

Installation Environment

The HELIOS® Processor is designed to be rack mounted in a central control room for fixed installations or flight cased for rental / temporary applications.

The unit has been qualified to operate in a dry environment within a temperature range of 10°C to 35°C.

NOTE: Never obstruct the airflow to the side ventilation slots. The front filters need to be regularly checked and cleaned.



WARNING: Below is a set of environmental conditions that must be met prior to installing Megapixel products. The installation and/or use of products in these environments not meeting these conditions may void all warranties.

- Installation locations must be free of moisture.
- Installation locations must be dust free.
- All heavy and dirty site work must be complete. This includes re-working or modifications to walls, ceiling and floor.
- All construction materials and debris must be removed, area swept, vacuum cleaned, and the floor wet-mopped.
- Building structure, roof, and walls are sealed and weatherproofed. Roof successfully tested for leaks.
- Outside drainage system and floor drains checked and tested to protect the equipment from flooding.
- Floors sealed and cleaned.
- All doors and windows installed and operational with weather seals.
- All final wall preparation complete including all taping, joint compound, and fire sealant. Walls to be primed and finish painted.
- Overhead fire sprinkler or suppression system installed and pressure tested.
- HVAC ducts blown free of debris. HVAC shall be operational/balanced and running 72 hours prior to equipment installation.

EMI Statement

FCC

This equipment has been tested and found to comply with the limits for a class A digital device, pursuant to Part 15 of the FCC rules. These limits are designed to provide reasonable protection against harmful interference when the equipment is operated in a commercial environment.

This equipment generates, uses, and can radiate radio frequency energy. If the equipment is not installed and used as directed in the instruction manual, it may cause harmful interference to radio communications. It is the responsibility of the user to correct any interference.

CQC

警告：在居住环境中，运行此设备可能会造成无线电干扰

Warning: Operation of this equipment in a residential environment may cause radio interference.

Carrying and Handling the Equipment

Before you handle the HELIOS® LED Processing Platform equipment, disconnect all cables and cords. Do not operate the HELIOS® LED Processing Platform equipment in areas with significant amounts of airborne dust or smoke, or near a humidifier. Tiny airborne particles can damage the equipment.

Power

Unplug the power cord (by disconnecting from the power source) and disconnect all other cables if any of the following conditions exist:

- The power cord or plug becomes frayed or otherwise damaged.
- Liquid has spilled onto the equipment.
- The equipment is exposed to rain or excess moisture or humidity.
- The equipment has been dropped, and has been damaged.
- You suspect that the equipment needs service or repair.
- You want to clean the case (use only the recommended procedure, described later in this document).



IMPORTANT: The only way to completely turn off power is to unplug the power cord.



WARNING: The AC cord has a three-wire grounding connector. This connector fits only a grounded AC outlet. If you are unable to insert the connector into an outlet because the outlet isn't grounded, contact a licensed electrician to replace the outlet with a properly grounded one. Do not defeat the purpose of the grounding pin.

Liquid Exposure

Keep the HELIOS® LED Processing Platform equipment away from all sources of liquid. Protect equipment from dampness, humidity, or wet weather, such as rain, snow, and fog.

Repairing

The HELIOS® LED Processing Platform equipment does not have any user-serviceable parts. Do not attempt to replace or repair any components inside the equipment. If the equipment needs service, contact the company that provided or installed the equipment. If you open the equipment or install items, you risk damaging the equipment. Such damage isn't covered by the limited warranty on the equipment.

Medical Device Interference

HELIOS® LED Processing Platform equipment contains components that emit electromagnetic fields, which may interfere with pacemakers, defibrillators, or other medical devices. Maintain a safe distance of separation between your medical device and equipment. Consult your physician and medical device manufacturer for information specific to your medical device. If you suspect equipment is interfering with your pacemaker or any other medical device, stop using the equipment.

Medical Conditions

If you have a medical condition that could be affected by using HELIOS® Processing equipment (e.g., seizures, blackouts), consult with your physician prior to using HELIOS® LED Processing Platform equipment.

High-Consequence Activities

HELIOS® LED Processing Platform equipment is not intended to be used where failure could lead to death, injury, or severe environmental damage.

Explosive Atmospheres

Using HELIOS® LED Processing Platform equipment in any area with a potentially explosive atmosphere (e.g., where the air contains high levels of flammable chemicals, vapors, or particles (such as grain, dust, or metal powders), may be hazardous. Obey all signs and instructions.

Using Connectors and Ports

Never force a connector into a port. When connecting a device, make sure the port is free of debris, that the connector matches the port, and that you have oriented the connector correctly in relation to the port.

Storing the Equipment

If you are going to store the HELIOS® LED Processing Platform equipment for an extended period of time, keep it in a cool and dry location (ideally, 71° F or 22° C).

Cleaning the Equipment

When cleaning the outside of the HELIOS® LED Processing Platform equipment and its components, first shut down the equipment, then unplug all cords and cables. Use canned air such as ‘Turbo Blast’ by ACL Staticide Inc. or a clean, soft, lint-free cloth to wipe the equipment exterior. Avoid getting moisture in any openings. Do not spray liquid on the equipment. Do not use sprays, solvents, abrasives, or cleaners.

Changes

Megapixel provides this manual ‘as is’ without warranty of any kind, either expressed or implied, including but not limited to the implied warranties of merchantability and fitness for a particular purpose. Megapixel may make improvements and/or changes to the product(s) and/or the program(s) described in this publication at any time without notice.

This publication could contain technical inaccuracies or typographical errors. Changes are periodically made to the information in this publication; these changes are incorporated in new editions of this publication.

Certifications



Table of Contents

Chapters

1 - System Components	1
1.1 Overview	1
1.2 HELIOS® Overview	2
1.3 HELIOS® Front Panel	3
1.4 HELIOS® Rear Panel	3
1.5 Network Switch Overview	5
1.5.1 RS12 Network Switch	5
1.5.2 M4250-12M2XF (MSM4214X) Network Switch	6
1.5.3 M4200-10MG-PoE+ (GSM4210P) Network Switch (No longer in production)	7
1.6 Display Tiles	8
1.7 Display Tile Components	9
2 - System Planning	10
2.1 Overview	10
2.2 Video Input	10
2.3 Custom DisplayPort and HDMI Input Data Rate Calculations	11
2.4 Custom ST 2110 Input Data Rate Calculations	11
2.5 Creating a Raster Map	12
2.6 Dual Input Cards	13
2.7 Data Distribution	13
3 - Connections	15
3.1 Overview	15
3.2 System Latency	15
3.3 HELIOS® Connections	16
4 - Networking	19
4.1 Overview	19
4.2 IP Addressing	20
5 - Configuration	23
5.1 Overview	23
5.2 Front Panel UI	23
5.3 Web UI	24
5.3.1 Processor Name	25
5.3.2 System Status Indicators	25
5.3.3 Feedback	25
5.3.4 Command Palette	26
5.3.5 Processor Stacks	27
5.3.6 Global Controls	28
5.3.7 Canvas Lock	32
5.3.8 Keyboard Shortcuts Menu	33
5.3.9 Advanced Mode	33

Table of Contents

Chapters

5.4 Creating Maps	34
5.4.1 Mapping Pane	35
5.4.2 Positioning Tools	36
5.4.3 Positioning Tools (Advanced)	36
5.4.4 Tile Configuration	37
5.4.5 Tile Test Patterns	37
5.4.6 Tile Groups	39
5.4.7 Baseline	43
5.4.8 Tile Notes	45
5.4.9 Tile Maintenance	46
5.4.10 Tile Maintenance (Advanced)	46
5.5 Input Pane	48
5.5.1 Input Details	49
5.5.2 NanoSync®	61
5.5.3 NanoSync® (Advanced)	62
5.5.4 Output Window	64
5.5.5 Output Window (Advanced)	65
5.5.6 Canvas Repeat - Output Window (Advanced)	67
5.5.7 Crop region (Advanced)	68
5.5.8 Input Adjustments	69
5.5.9 Input Adjustments (Advanced)	70
5.5.10 EOTF Adjustments (Advanced)	71
5.5.11 Signal Transformation Best Practices	76
5.5.12 High Dynamic Range	77
5.6 Output Pane	79
5.6.1 Display Gamut	79
5.6.2 Calibration Report	80
5.6.3 Validating HDR Display Performance	81
5.6.4 Custom Gamut (Advanced)	82
5.6.5 Display bit depth	83
5.6.6 LightScience®	83
5.6.7 Output Pane (Advanced)	84
5.6.8 Color grading tools - Color wheels	84
5.6.9 Color grading tools - Curves	85
5.6.10 Ultra Low Latency (Advanced)	87
5.6.11 Output adjustments (Advanced)	91
5.7 GhostFrame® (Advanced)	92
5.7.1 GhostFrame® Licensing	93
5.7.2 GhostFrame® Configuration	94
5.7.3 Sub-frame Slice Gains	96
5.7.4 Video Streams	97
5.7.5 Camera (Advanced)	99
5.8 Devices Pane	100
5.8.1 Processing Tab	100
5.8.2 Processor	101
5.8.3 Network Switches	103
5.8.4 Display Devices Tab	104

Table of Contents

Chapters

5.9 Health Pane	105
5.9.1 Alerts	105
5.9.2 Temperature Heat Map	106
5.9.3 Humidity Heat Map	107
5.9.4 Network Errors Heat Map	108
5.9.5 Reports	109
5.9.6 Troubleshooting with Counters Reports	110
5.10 Settings Pane	111
5.10.1 Processor Settings	111
5.11 Security (Advanced) User Authentication	123
5.11.1 Security (Advanced) Previews	127
5.12 Still Store	129
5.13 Scheduler (Advanced)	130
5.14 Saved Configurations	135
5.15 Update Center	139
5.15.1 Software upgrade steps	140
5.16 Shortcuts	141
5.17 About	142
5.18 Preview Pane	143
5.19 Seams Pane	145
5.20 Adjustments Pane	150

Table of Contents

Appendices

A - Maintenance	151
A.1 General Maintenance	151
A.2 Processor Filter Maintenance	151
A.3 Processor Fuse Replacement	152
B - Unknown User / Password	153
B.1 Overview	153
B.2 Restoring to Factory Default	154
C - Troubleshooting Fiber	155
C.1 Overview	155
C.2 Troubleshooting checklist:	155
C.3 SFP+ Types	156
C.4 Testing SFP+ units	156
C.5 Incompatible SFP Alert	157
C.6 Troubleshooting License Checklist:	157
D - Low Level Noise Reduction	159
D.1 Overview	159
D.2 Low Level Noise Reduction Steps	160
E - Content to Panel Luminance Curves	162
E.1 Overview	162
F - Data Redundancy	165
F.1 Overview	165
F.2 Seamless Redundancy	165
F.3 Seamless Loop™ - HELIOS® Jr. Redundancy	166
F.4 Seamless Loop™ - Tile Link Redundancy	167
F.5 Seamless Loop™ - Switch Redundancy	168
F.6 Redundancy Settings	169
F.7 Processor Role	169
F.8 Redundancy Modes	170
F.9 Override test pattern (when in backup role)	171
F.10 Take processor offline on input failure	171
F.11 Redundancy States	172
F.12 Manual Overrides	172
F.13 Redundant System Status Indicator	173
F.14 Processor Stacking	174
F.15 Front Panel Redundancy Info	174
F.16 Devices Pane Processing Tab	175
F.17 Devices Pane Link Icon	176
F.18 Software Upgrade Process	176
F.19 Troubleshooting Failover Mode Redundant Systems	177
F.20 Troubleshooting Seamless Mode Redundant Systems	177

Table of Contents

Appendices

G - ST 2110	178
G.1 Overview	178
G.2 Example SDP Record	180
G.2.1 Session Level	180
G.2.2 Media Level	180
G.2.3 Media Level Attributes	180
G.3 NMOS Overview	181
G.3.1 NMOS Setup	183
G.4 PTP Settings	184
G.5 ST 2022-7 Redundant Streams	185
H - Masks	186
H.1 Overview	186
H.2 Mask Image Requirements	187
H.3 Mask Behavior	187
H.4 Tile Group Behavior	187
H.5 Mask Nudging	187
H.6 Mask Algorithm	188
H.7 Mask Mayhem	188
H.8 Example Masks	189
I - HELIOS® HTTPS	193
I.1 Overview	193
I.2 Workflow	193
I.3 Certificate & Key PEM file format	194
I.4 Including intermediary certificates	194
I.5 Verifying uploaded certificate	195
I.6 HSTS	196
I.7 Generating a self-signed certificate	196
I.8 Supported ciphers	197
I.9 Security settings for HTTPS	198
J - HDR Workflows	199
J.1 HDR as a Pipeline, Not a Setting	199
J.2 Core HDR Parameters	200
J.3 Common Points of Variation	200
J.4 Upstream Pipeline Considerations	201
J.4.1 Content Creation	201
J.4.2 Content Packaging and Playback	202
J.4.3 Signal Transport	202
J.5 HDR Quick Diagnostic Checklist	203
J.6 Validation and Measurement	204

Table of Contents

Appendices

K - Technical Specifications	205
K.1 RS12 Network Switch - Specifications Table	205
K.2 M4250-12M2XF (MSM4214X) Network Switch - Specifications Table	205
K.3 M4200-10MG-PoE+ (GSM4210P) Network Switch - Specifications Table	206
K.4 I/O Module shipping weights	206
K.5 HELIOS® - Specifications Table	207
K.6 HELIOS® - I/O Configurations	208
K.7 HELIOS® - Input Capability Matrices	209
K.8 HELIOS® - HDMI 2.1 Specifications	211
K.9 HELIOS® - ST 2110 Input Specifications	212
K.10 HELIOS® - Supported SDI Input Formats	213
K.11 HELIOS® - Megapixel SFPs	214
K.12 HELIOS® - Supported 100GB SFPs	215
K.13 HELIOS® - Supported DAC (Direct Attached Cables)	215
K.14 HELIOS® & Switch - Output Port Capacity (Pixels)	216
K.15 HELIOS® - Fiber Out / Data to GSM4210P Network Switch	216
K.16 HELIOS® - Network Ports	217
K.17 HELIOS® - API	217
K.18 HELIOS® & Tile - Sensor Ranges	218
K.19 HELIOS® - Normal Voltage Ranges	218
K.20 HELIOS® - Functions Tracked by Stacking	219
K.21 HELIOS® - Shipping Info.	220
K.22 HELIOS® - Dimensions	220
L - Glossary	221
L.1 Megapixel Proprietary Terms	221
L.2 Video & Color Standards	222
L.3 Networking & Protocols	224

1 - System Components

1.1 Overview

The HELIOS® LED Processing Platform was designed to support high-density display products for use in studios, live events, and fixed installs. The HELIOS® is compatible with video sources that have up to 8K resolution (i.e., media servers, production network switchers, and broadcast cameras). The HELIOS® system will automatically integrate system components as they are connected or replaced.

The HELIOS® system consists of a processor unit and one or more network switches. The HELIOS® is designed to be located near the video source. The HELIOS® ingests the source video and converts it into a fiber signal. The HELIOS® is also responsible for serving the web-based user interface (web UI) that is the user interface of the system. The network switches carry both the video signal and the communication signals to and from panels. As such, there is information passing in both directions on the HELIOS® fiber links that can be up to 10km in length.

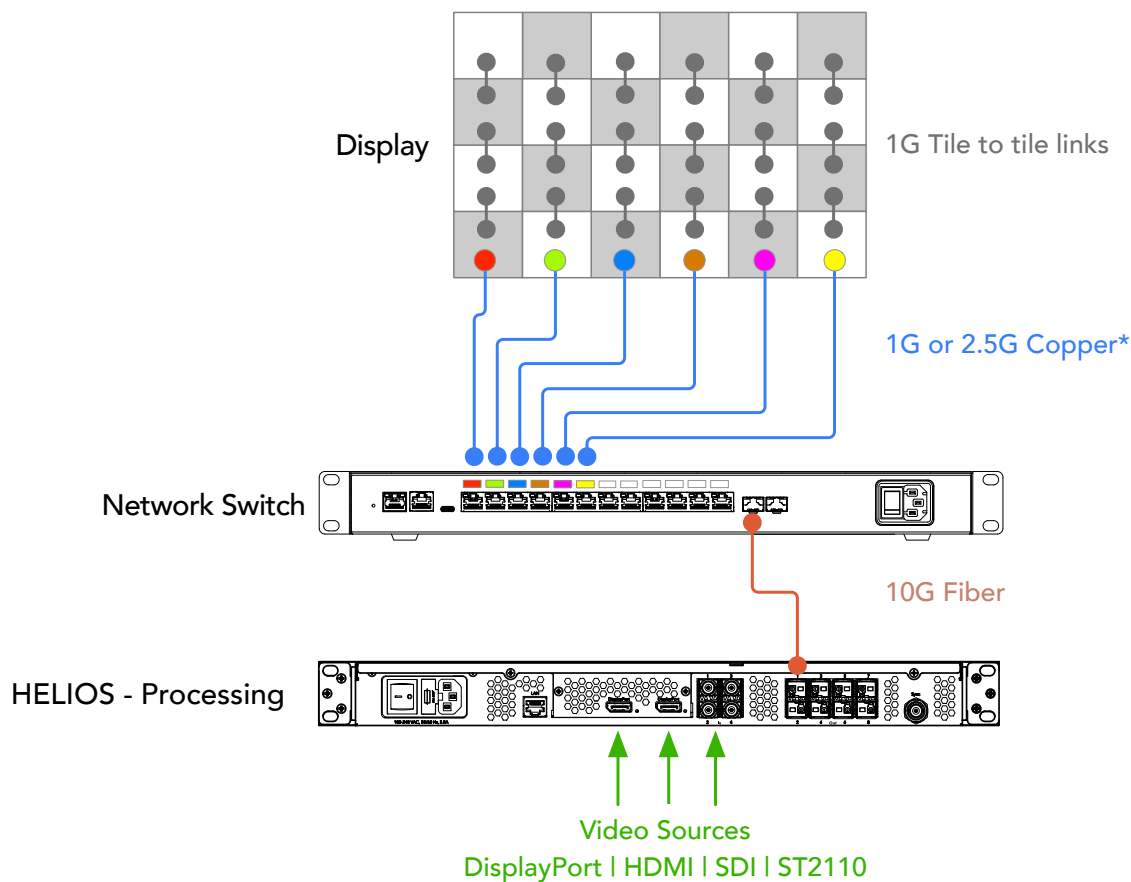

Figure 1: HELIOS® system diagram

* 2.5G connectivity is dependent on the tile design capabilities set by the tile manufacturer. Check tile specifications to ensure the tiles are 2.5G capable. Most tiles are only 1G capable.

1.2 HELIOS® Overview

The HELIOS® is a one RU (1.75”) tall rack mount unit that can receive video in resolutions up to 8K and outputs that video as a proprietary stream to compatible video panels.

The HELIOS® is capable of receiving HDMI 2.0b, HDMI 2.1, DisplayPort 1.4, SDI, and ST 2110 signals. The HDMI and DisplayPort inputs are designed to be modular. Alternate combinations of DisplayPort and HDMI 2.0b inputs are supported (e.g., two DisplayPort, or two HDMI 2.0b). Contact your Megapixel representative for more details. SDI inputs are provided by four Megapixel SFP+ units which can receive quad 12G SDI. To receive ST 2110, the SDI SFPs are replaced with ones that support the ST 2110 protocol. The default 8K HELIOS® configuration consists of (1) x HDMI, (1) x DisplayPort and (4) x SDI.

The system is configured remotely via a web UI running Chrome or Safari browsers. The input image can be scaled up or down to suit LED panel configurations and also has all the common controls for brightness, gamma, color temperature, etc.

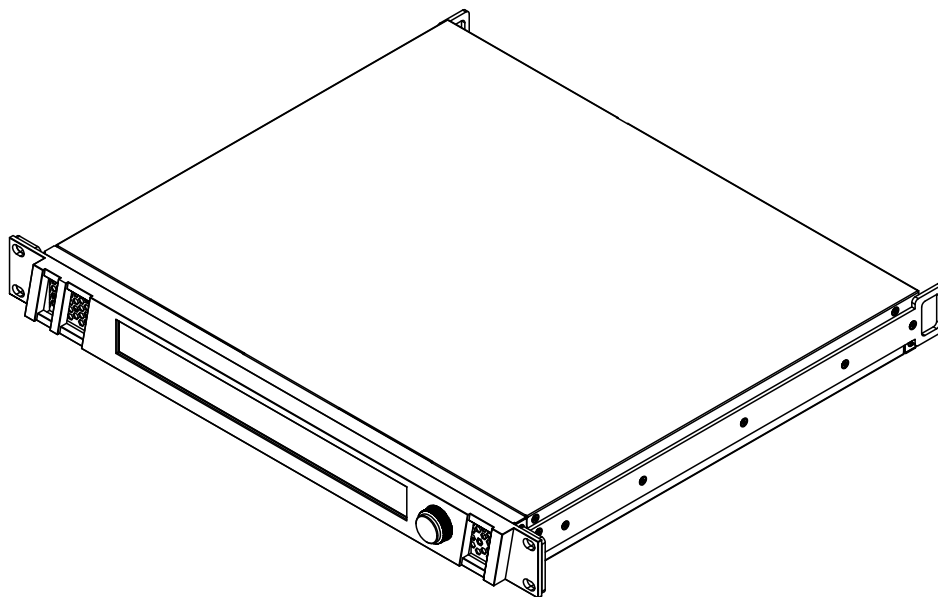

Figure 2: HELIOS®

1.3 HELIOS® Front Panel

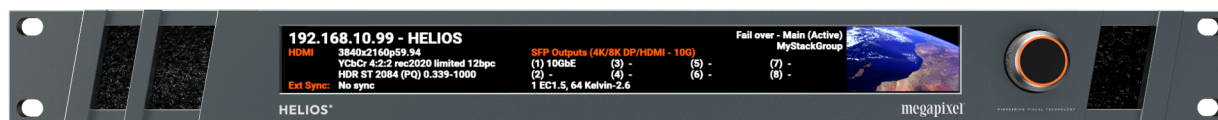

Figure 3: HELIOS® front items

Configuration Interface – The front of the HELIOS® has an LCD display and turn/push knob interface.

Air Inlets – Slots to the left and right of the LCD display are filtered vents for chassis airflow.

1.4 HELIOS® Rear Panel

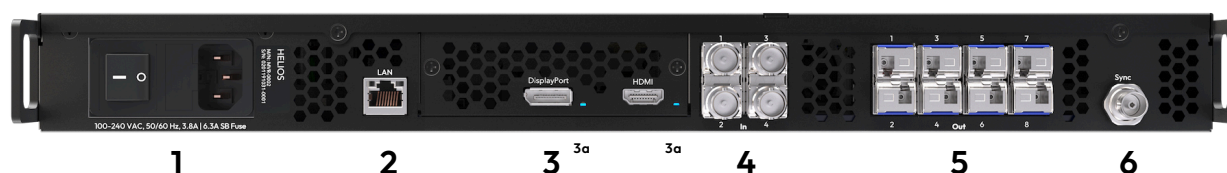

Figure 4: HELIOS® rear items

- 1 - **Power Entry Module** – A rocker switch, a fuse holder, and an IEC C14 style socket. The HELIOS® typical power usage is 65W maximum. Fuse information can be found in Section [K.5](#) of the tech specs.
- 2 - **Control Port** – An Ethernet port. This port should be used to place the HELIOS® on the system control LAN. A laptop may directly connect, or in larger systems a wireless router connects here.
- 3 - **VFMC Video Inputs** – The video inputs are modular. At the center of the unit is a removable plate that houses removable VFMC input boards. The HELIOS® system supports HDMI and DisplayPort cards in these slots. HELIOS® units can be configured with dual HDMI or dual DisplayPort cards.
- 3a - **VFMC Video Input Indicators** – A small status LED next to each VFMC input link.

Indicator Color	Meaning
White	System boot
Black	No link (no cable)
Yellow	Valid link, no video
Blue	Valid link, valid video
Red	Error detected in the last 1.25 sec
Green / Cyan / Magenta	Training cycle

4 - SFP+ Inputs — Four (4) SFP+ slots provide copper SDI inputs. Each input requires a Megapixel 12G SFP+ and supports formats up to 12G SDI. See the [Input Capability Matrix](#) in Appendix K for details. Indicators on each SFP+ slot show link status.

Indicator Color	Meaning
Green	Receiving a carrier signal
Blue	Valid frame detected

5 - SFP+ Outputs — HELIOS® Standard units support up to eight (8) Megapixel 10G fiber SFP+ outputs for data transmission to the display. Likewise, HELIOS® Jr. units support up to eight (8) Megapixel 1G copper SFP outputs. Indicators on each SFP+ slot show link status.

Indicator Color	Meaning
Green	Link to switch
Blue	Connected to tiles

6 - External Sync — The BNC connector to the right of the fiber outputs allows the HELIOS® to receive genlock timing signals. An external sync is required when using multiple processors for data redundancy.

1.5 Network Switch Overview

The HELIOS® system leverages network switches for data distribution to the tiles. The network switch connects to the HELIOS® via 10Gb fiber SFP+ uplinks and has twelve (12) 1 / 2.5Gb copper Ethernet ports that serve as outputs to the display. Systems may have up to eight (8) switches per HELIOS® and are typically co-located with the display. All user controllable functions of the network switch are accessed via the HELIOS® web UI.

1.5.1 RS12 Network Switch

The RS12 (MVR-0050) is a ruggedized HELIOS® compatible network switch. Custom-engineered to withstand rigorous outdoor environments when used with the optional weather resistant enclosure (MVR-0051) or to provide an expanded selection of mounting points for indoor racks or rear of screen, the RS12 offers more flexibility for HELIOS® deployments.

12 x Display Outputs — 1Gb/2.5Gb copper Ethernet ports, transmit video and control data to and from connected panels. The RS12 makes use of etherCON CAT6A panel mount connectors. These connectors are compatible with the following connector types: etherCON TOP, etherCON, and etherCON CAT6A. They are NOT compatible with etherCON CAT6 family connectors.

Fiber ports — Port 13 is used as the primary data channel to HELIOS®. All HELIOS® to switch communication is over port 13. Port 14 can be used as an auxiliary data channel, adding 10Gb of additional bandwidth between the HELIOS® and the RS12. Either Neutrik opticalCON DUO with single mode fiber or an individual LC single mode fiber cable can be used.

Power Inlet — a Neutrik™ powerCON TRUE1 Input (100V-240V, 50/60Hz, 16A).

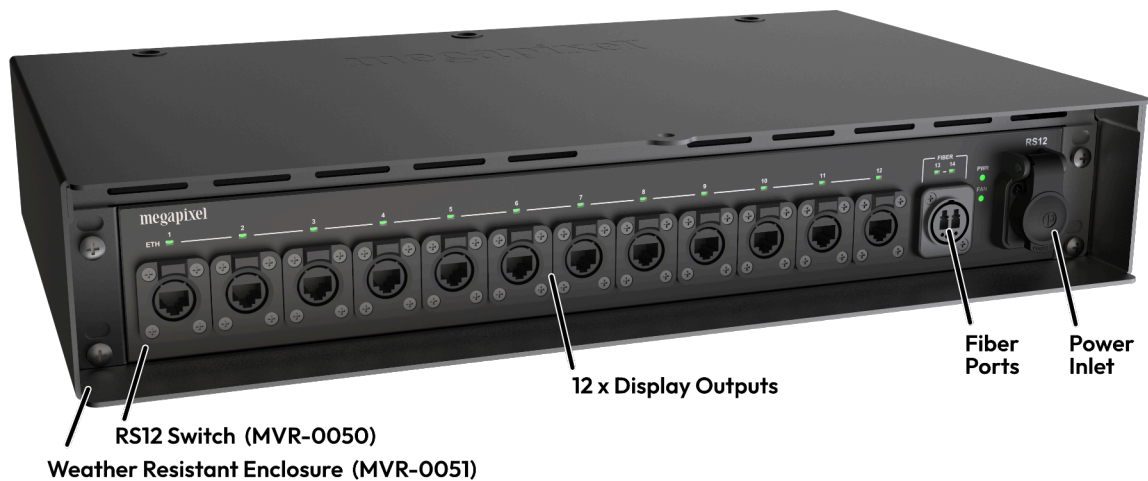

Figure 5: RS12 Network switch

NOTE: Do not factory reset switches. A factory reset switch requires an RMA to Megapixel to restore to functionality.

1.5 Network Switch Overview

1.5.2 M4250-12M2XF (MSM4214X) Network Switch

OOB and Console ports — These ports are never connected in a HELIOS® system.

Display Outputs — 1Gb/2.5Gb copper Ethernet ports, transmit video and control data to and from panels.

Port 13 — Input from HELIOS®, a 10Gb fiber SFP+ input, receives display data from HELIOS® processor.

Port 14 — Unlike the legacy switch (GSM4210P shown on the next page) the MSM4214X switch does not support copper SFPs. With the addition of a 10Gb SFP, Port 14 can be used as an auxiliary data channel, adding 10Gb of additional bandwidth between the HELIOS® and the switch. All HELIOS® to switch communication is still sent over port 13. Ports 13 and 14 are not interchangeable.

Power Inlet — IEC C14 A/C power connector. The switch will boot as soon as power is supplied and switched on.

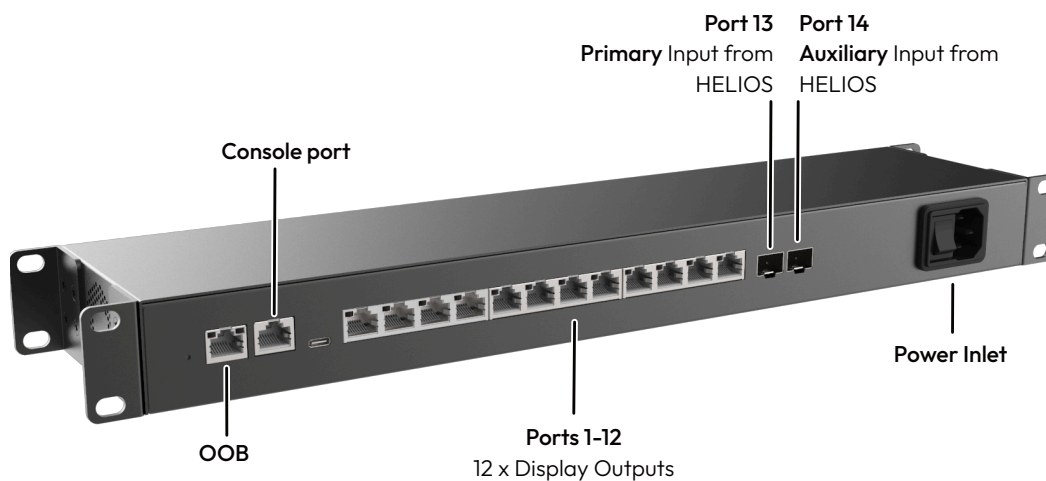

Figure 6: Network switch MSM4214X

NOTE: Do not factory reset switches. A factory reset switch requires an RMA to Megapixel to restore to functionality.

1.5 Network Switch Overview

1.5.3 M4200-10MG-PoE+ (GSM4210P) Network Switch (No longer in production)

OOB and Serial Console ports — These ports are never connected in a HELIOS® system.

Display Outputs — 1Gb/2.5Gb copper Ethernet ports, transmit video and control data to and from connected panels. The second SFP port (shown fitted with a black plug in the image below) can be used as an additional copper output when fitted with a 1Gb copper SFP module (available from Megapixel).

Input from HELIOS® — 10Gb fiber SFP+ input, receives display data from HELIOS® processor. This switch does not support dual 10Gb inputs from HELIOS®.

Power Inlet — IEC C14 A/C power connector. The network switch will boot as soon as power is supplied.

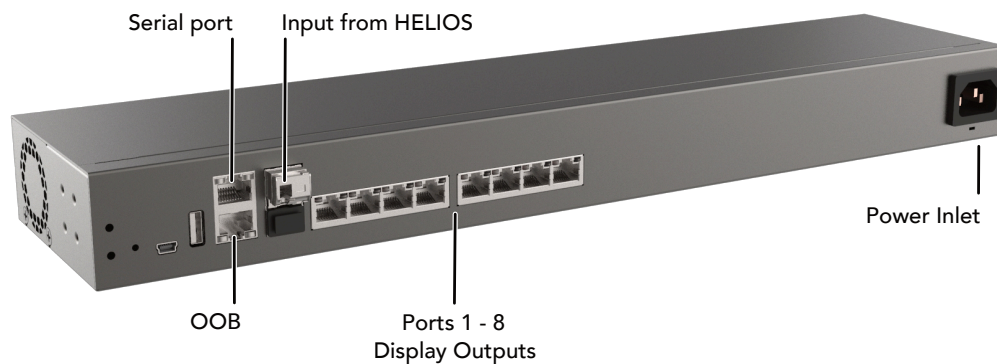

Figure 7: Legacy switch GSM4210P

NOTE: Do not factory reset switches. A factory reset switch requires an RMA to Megapixel to restore to functionality.

1.6 Display Tiles

Display tiles are light emissive video panels containing receiver cards. They operate at the end of the video signal chain. Display tiles come in many shapes and sizes from a variety of vendors. Below are some common characteristics.

Input — Copper Ethernet input receives display data from a network switch or from another tile ahead of it in the chain.

Output — Copper Ethernet outputs send video and control data to the tiles downstream.

Power — Power must be supplied to each tile. Power connectors differ for each tile type.

Status Indicators — On the rear of each display tile is a multicolor indicator button, the exact location varies by tile type. The table below details the buttons functions and the meaning of each indicator color.

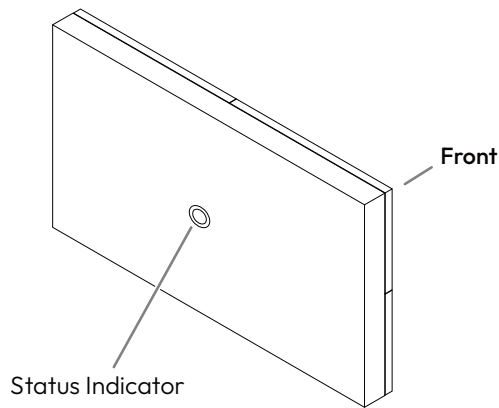

Figure 8: Status Indicator

Indicator Color	Meaning
White	Booting
Cyan	Booted into safe mode
Green	Ready (No network connection)
Blue Single Flash	No HELIOS® connection (1 tile link active)
Blue Double Flash	No HELIOS® connection (2 tile links active)
Blue Solid	Connected to HELIOS® (Normal operation)
Yellow	Internal Pattern (press and hold center button 4 seconds to enter and leave this mode). Press and release to advance to the next pattern.
Red	Flash once every 10 sec to indicate a system error.

NOTE: Tiles store LDM seam information, the currently selected LDM configuration, and [tile notes](#). All other system data is stored on the HELIOS®.

1.7 Display Tile Components

Displays are made up of modular LED tiles. The modular tiles connect together to form a seamless display surface. Each individual tile is made up of several sub components.

LED Module (LDM) — The front of LED tiles have one or more LDMs. LDMs form the front of the tiles as they are populated with the display LEDs.

Hub PCB — Provides the connection between the LDMs and the tile's receiver card.

PX1 Receiver Card — The HELIOS® communicates in a protocol called PXL. The LED tile must have a PXL compatible receiver card like the PX1 to receive and decode the HELIOS® video streams and the HELIOS® tile management messages. Additionally, display tiles can have a variety of onboard sensors (fan, CPU, PSU) that they periodically report on to the HELIOS® processor.

Frame — All of the tile electronics are housed in a purpose built chassis. Chassis are precision engineered to minimize gaps and other physical inconsistencies to provide a seamless display surface.

The image below shows a group of four (4) tiles with one (1) tile exploded to show the components mentioned above.

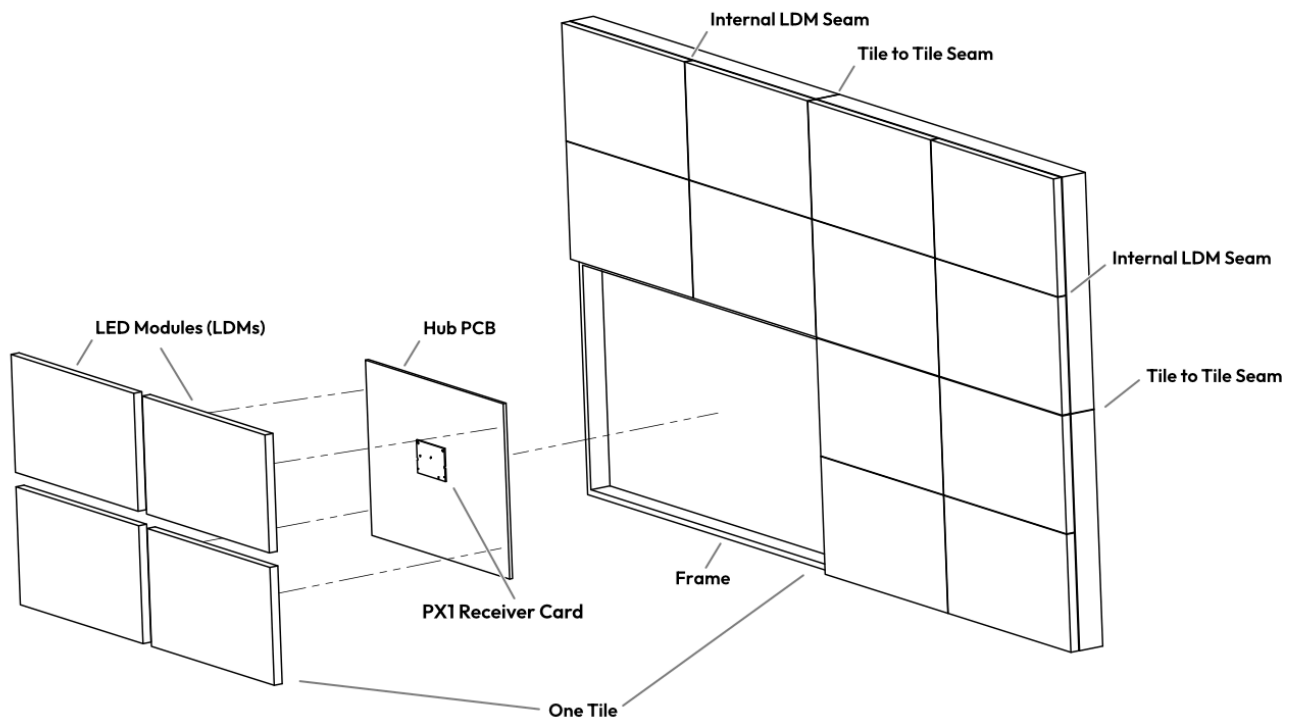

Figure 9: Display tile components

2 - System Planning

2.1 Overview

This chapter covers the planning activities required before ordering equipment. If assistance is needed with any of the items below, Megapixel is available to assist. Please contact a sales associate at sales@megapixelvr.com.

Ensure compatibility of the display product being considered with the HELIOS® system. The HELIOS® system can be used with a continuously expanding list of products. Please see the HELIOS® software release notes available on the Megapixel website for current product compatibility <https://megapixelvr.com/support/helios>.

2.2 Video Input

Pixel dimensions — The number of pixels in the final display is a major factor in selecting a video input type. If at all possible, it is best to first settle on the quantity of pixels and the necessary pixel dimensions for the system before selecting an input format. DP, HDMI, and ST 2110 support custom pixel resolutions, SDI does not.

Input formats — Select an input format that can support the required pixels. HELIOS® accepts the following input formats:

Input Format	Maximum Data Rate	Custom Resolutions
SDI	12 Gbps	✗
HDMI 2.0b	14.4 Gbps	✓
HDMI 2.1	48 Gbps*	✓**
DisplayPort 1.4	25.92 Gbps	✓
ST 2110 10G	4 x 10 Gbps	✓
ST 2110 100G	1 x 100 Gbps	✓

* 48Gbps max bandwidth — requires an “Ultra High Speed” HDMI cable.

**For custom resolutions, the HDMI 2.1 resolution width must be a multiple of four (4).

NOTES:

- HELIOS® HDMI inputs support HDMI 2.0b signaling up to 4K60 and HDCP 2.x on protected content (2.2 or later; see the HDCP entry in [Appendix L](#) for details). HDCP 1.4 is not supported; sources that require HDCP 1.4 interoperability may fail to display video.
- The Input Capabilities Matrices can be found in Appendix [K.7](#). With format specific (HDMI 2.1, ST 2110, SDI) details in Sections [K.8-K.10](#).

2.3 Custom DisplayPort and HDMI Input Data Rate Calculations

DisplayPort and HDMI support custom input resolutions and frame rates. To confirm that the desired format fits within the limitations of the input data link, the following formula can be used.

DP/HDMI Data Rate Formula:

$$\text{Data Rate} = \text{Total Width} \times \text{Total Height} \times \text{Frame Rate} \times \text{Bits/Color} \times \text{Pixel Format}$$

Pixel Format value = **2** for 4:2:2 or **3** for RGB or 4:4:4.

Total Width and **Total Height** include the blanking time. As an example, a 5K (5120×2880), 60 Hz, 8 bits/color RGB signal with CVT Reduced Blanking v2 requires:

$$(5200 \times 2962) \times 60 \times 8 \times 3 = 22,179,456,000 \text{ bits/second } (\sim 22.18 \text{ Gbit/s})$$

This data rate will fit on a DisplayPort 1.4 link as it has a max throughput of 25.92 Gbit/s, but will not fit on an HDMI 2.0 link with max throughput of 14.4 Gbit/s.

2.4 Custom ST 2110 Input Data Rate Calculations

ST 2110 supports custom input resolutions and frame rates. ST 2110 does not have blanking pixels like DisplayPort and HDMI. However, ST 2110 incurs overhead due to packetization of the data. This overhead is at least 5%, and more typically around 7%. Also note that there may be management or other traffic on the Ethernet network reducing the available bandwidth.

ST 2110 Data Rate Formula:

$$\text{Data Rate} = \text{Active Width} \times \text{Active Height} \times \text{Frame Rate} \times \text{Bits/Color} \times \text{Pixel Format} \times (1 + \text{Packet Overhead})$$

Pixel Format value = **2** for 4:2:2 or **3** for RGB or 4:4:4.

As an example, a 5K (5120×2880), 60 Hz, 8 bits/color RGB signal with 7% overhead requires:

$$(5120 \times 2880) \times 60 \times 8 \times 3 \times 1.07 = 22,720,020,480 \text{ bits/second } (\sim 22.7 \text{ Gbit/s}^*)$$

This data rate will fit on a 100G Ethernet link but not on a 10G Ethernet link.

For ST 2022-7 redundancy, the data rate is doubled to account for both redundant streams.

NOTE: HELIOS® has an overall system pixel rate limit of 2,124,000,000 active pixels per second. This limit only applies to the pixel rate and is not affected by color depth, color format, blanking, redundancy, etc.

*This document uses SI prefixes, G = Giga (10⁹ or 1,000,000,000). This is different from IEC 'Xi' notation that is used for power of 2 units. In IEC 'Xi' notation, Gi = Gibibits (1,073,741,824). The 'i' means binary (2³⁰), not decimal (10⁹).

2.5 Creating a Raster Map

It is a good idea to create a raster map drawing to document which region of the video signal serves each display tile. The example below, contains two separate displays (blue tiles). In this case, the pixel dimensions of both displays will fit on a 6K raster. The larger 8K and DCI 8K rasters are shown for reference.

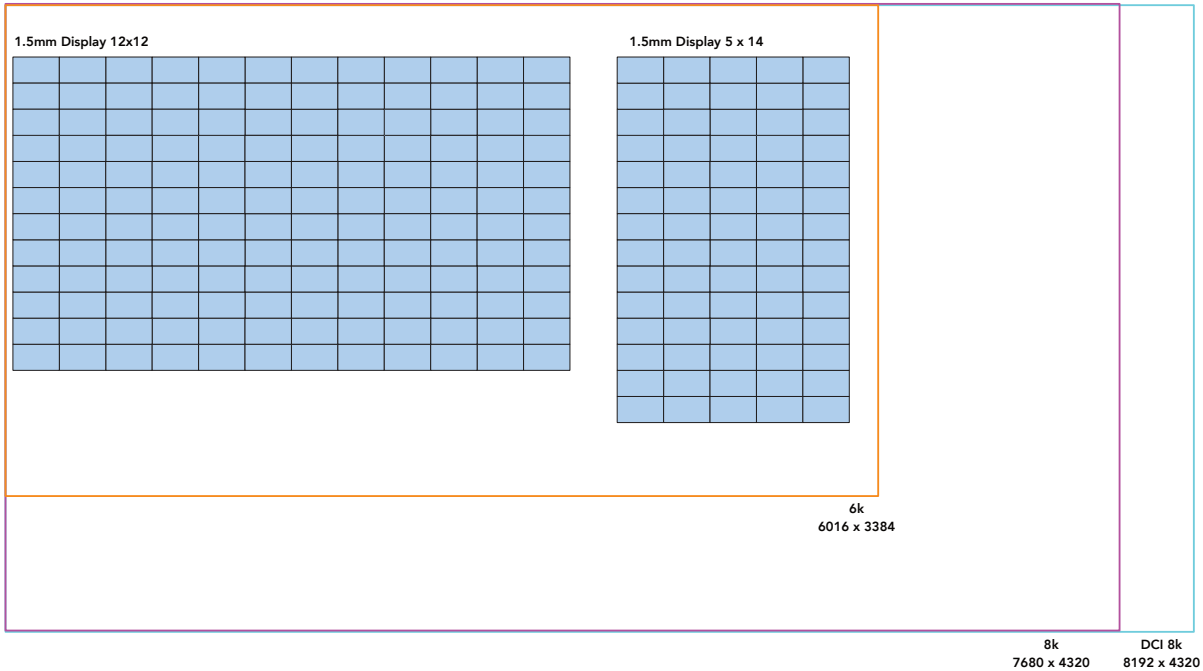

Figure 10: Example raster map

Sometimes, the 'as built' shape of the system does not fit any horizontal or vertical rasters, but the total number of pixels can. This is the case with a long ribbon display. Rasters can be rearranged, (within certain limitations) on the front end if necessary. In the end, the picture to be transmitted to a display needs to fit inside of the pixel dimensions of one of the four supported input signals (HDMI, DisplayPort, SDI, or ST 2110). For long strip style displays this means that the inbound picture needs to be divided into segments, these are labeled with capital letters in the example below (A, B, C, etc.). Content can be created in segments or the segmentation can be accomplished with media processing equipment prior to the HELIOS®. The example below shows a dual HDMI input configuration (see the following section on dual input cards).

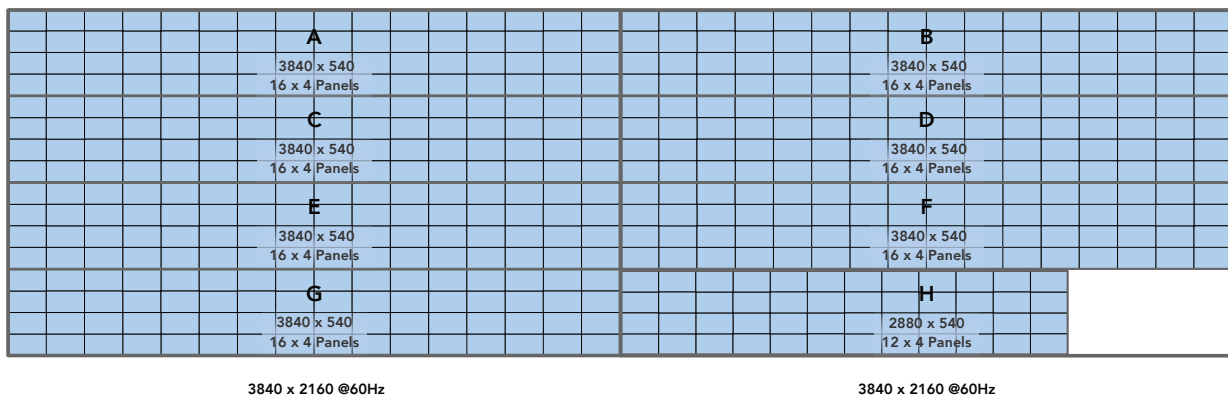

Figure 11: Long ribbon display map example

NOTE: Extreme cases of very tall and narrow displays may not work due to overhead timing constraints of blanking time.

2.6 Dual Input Cards

If the total number of pixels will not fit any single input raster, the system can be fed video from multiple input cards. A HELIOS® with the necessary hardware (dual DisplayPort or dual HDMI cards) can receive dual video signals of the same type of signal. When HELIOS® is outfitted with two of the same card type (DisplayPort or HDMI) it will stitch the two rasters together into one continuous output to tiles. Please see the Stitched Inputs in [Section 5.5.1](#) for more information on configuring this mode.

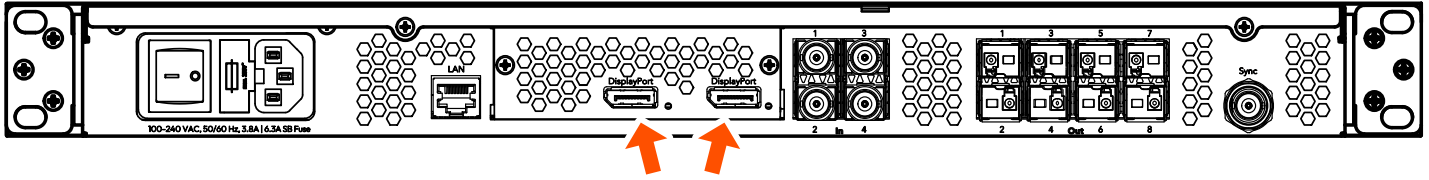

Figure 12: Dual DisplayPort input card configuration

2.7 Data Distribution

At this point it can be helpful to draw out the data system topology. Decide if the display will be cabled vertically or horizontally. Calculate the number of network switches it will take to distribute data to the display. In the system example below we use an example tile with the pixel dimensions 480 x 270 (tiles are 129,600 pixels). From the [Output Port Capacity](#) table in Appendix K we see that a 1Gbps switch port running a color bit depth of 12 at 30Hz can support up to 821,000 pixels ($821,000 / 129,600 = 6.3$). This tells us we can safely put 6 of these tiles on a 1Gb link. If bit depth and frequency requirements change, the system bandwidth must be recalculated.

↓

Bit Depth	10	10	10	12	12	12
Connection	Switch to Tiles	Switch to Tiles	HELIOS to Switch	Switch to Tiles	Switch to Tiles	HELIOS to Switch
Ethernet Speed (Gbps)	1	2.5*	10	1	2.5*	10
Video FPS						
24	1,237,000	3,094,000	8,075,000	1,031,000	2,578,000	8,075,000
25	1,187,000	2,968,000	8,075,000	989,000	2,473,000	8,075,000
→ 30	985,000	2,464,000	8,075,000	821,000	2,053,000	8,075,000
48	608,000	1,520,000	6,082,000	506,000	1,267,000	5,068,000
50	583,000	1,457,000	5,830,000	485,000	1,214,000	4,858,000
60	482,000	1,205,000	4,823,000	401,000	1,004,000	4,019,000
120	230,000	576,000	2,306,000	192,000	480,000	1,921,000
144	188,000	471,000	1,886,000	157,000	393,000	1,572,000
180	146,000	366,000	1,466,000	122,000	305,000	1,222,000
200	129,000	324,000	1,299,000	108,000	270,000	1,082,000
240	104,000	261,000	1,047,000	87,000	218,000	872,000

Figure 13: Output capacity table

Check to make sure the entire data load on each network switch is within the limits of 10Gb fiber. In this case, we are using a color bit depth of 12 at 30Hz. Regardless of the bit depth or frame rate, the 10Gb link can support up to $8,500,000 \text{ pixels} / 129,600 = 65.58$ example tiles per 10Gb link. With only 24 tiles in the example system we know we are well within the limits. Always aim to distribute data evenly, spread the load across switches and switch ports as evenly as possible.

2.7 Data Distribution

Cable infrastructure — Check that the types of cables chosen are appropriate for the display type and for the location. This is the point at which site specific considerations need to be made.

Important items to check:

- Where will the video source device reside?
- Is the HELIOS® close enough to the video source device to be within the specification of the video protocol being used. Confirm the distances needed with the protocol and cable type. Even if a protocol supports long distances, cable quality plays a major factor in the signal quality.
- Is there power for the HELIOS® at the location?
- Has power for the network switches been allotted?
- What is the distance from the HELIOS® to the network switches at the display? Is this under the 10km specification of the single-mode fiber?
- What is the distance from the network switch to the first panel in the display that each drives? Is this under the 100 meter limit of the copper Ethernet signal?

3 - Connections

3.1 Overview

The HELIOS® system consists of the HELIOS®, the network switches, and the fiber link between them. The HELIOS® is designed to be the receiver unit that the primary video signal connects to. We recommend installing the HELIOS® near source equipment. The network switches are intended to be placed next to the LED display panels. The system is always aware of the components that are connected to it and where the components are connected.

3.2 System Latency

The complete HELIOS® system — from input to viewer eyeball — typically requires three (3) frames of latency, regardless of input frame rate:

Stage	Latency
HELIOS® receives and processes the signal	1 frame
Tile reads HELIOS® data	1 frame
Tile sends data to LED driver chips	1 frame
Total	3 frames

Actual tile latency varies by tile type. When comparing latency across systems, note that manufacturers often only state the latency of their processor and/or receiver card — not the full signal chain.

Frame rate and latency

Running the system at a higher frame rate reduces the total delay time in milliseconds:

Frame rate	3 frames =
60 Hz	50 ms
120 Hz	25 ms

NOTES:

- High frame rate systems require the entire image pipeline — from media server to camera shutters — to be in sync. Plan accordingly.
- A 120Hz input source halves the maximum pixel capacity — for example, from 4,250,000 to 2,125,000 pixels per 10Gb HELIOS® output port.
- Ultra Low Latency (ULL) can reduce total system latency to as low as one (1) frame. See [Section 5.6.10](#) for details.

3.3 HELIOS® Connections

Power — A/C power is supplied to the built-in redundant power supplies of the HELIOS® on a C14 style IEC connector. Next to the power input connector is a rocker switch. When power is turned ON, the system will begin to boot. After about 15 seconds the front LCD display will be lit. When the boot logo disappears, the HELIOS® is ready for use. The HELIOS® should be powered OFF via the rocker switch on the rear of the unit.

User Interface — The HELIOS® system can be used with a wide variety of LED display products. It is necessary to configure the system to the products in use. The mapping of the HELIOS® system is accomplished with a web user interface. The web UI runs on any remote host capable of running a modern web browser such as Chrome or Safari. To communicate with the HELIOS® system, the web UI host must be configured to be on the same LAN as the HELIOS® (see Chapter 4, Networking).

Input Signals — The HELIOS® accepts HDMI 2.0b, HDMI 2.1, DisplayPort, SDI, and ST 2110 signals for input. For HDMI inputs, HELIOS® supports HDMI 2.0b signaling and HDCP 2.x content protection. HDCP 1.4 is not supported. Sources that attempt to use HDCP 1.4 may experience link instability or a loss of video. See the [Technical Specifications](#) in Appendix K for the full list of all the compatible formats and resolutions. Interlaced signals are not supported. When synchronization is needed such as with redundant systems, the HELIOS® must be provided with a genlock signal.

Output Signal to Displays — The output ports of the HELIOS® transmit video and control data over LC-LC, 9/125 Single mode (SMF) OS1 (<=1000m) or OS2 fiber to network switches, which in turn send the data on to the display devices via copper Ethernet cables. In a standard system configuration a single 10G link provides the display data to the network switch.

Dual 10G links — HELIOS® also supports dual aggregated 10G links to the RS12 and the M4250 network switches. M4200 switches do not support this feature. Dual links expand the total bandwidth between the HELIOS® and the switch to 20G. To run a dual 10G uplink system simply connect two of the HELIOS® 10G fiber outputs to Ports 13 and 14 of a fully supported network switch (see note below). Ports 13 and 14 on a switch are not interchangeable. Port 13 always remains a primary port for a switch with all switch management communication from the HELIOS® traveling up Port 13. If Port 14 is disconnected, bandwidth is simply reduced. If only Port 14 is connected, the system will not be functional since the switch management data from the HELIOS® would be missing. The simplified system diagram below shows how the tile data is routed in a dual 10G configuration. Port 13 tile data is directed to copper tile outputs 1-6. Port 14 tile data is directed to copper tile outputs 7-12.

3.3 HELIOS® Connections

The diagram below shows a basic HELIOS® system with dual 10G fiber uplinks. Video sources connect to the HELIOS® processor, which outputs via two 10G fiber connections to an RS12 network switch. The switch distributes data to the display tiles over 1G or 2.5G copper connections, with 1G tile-to-tile links completing the chain.

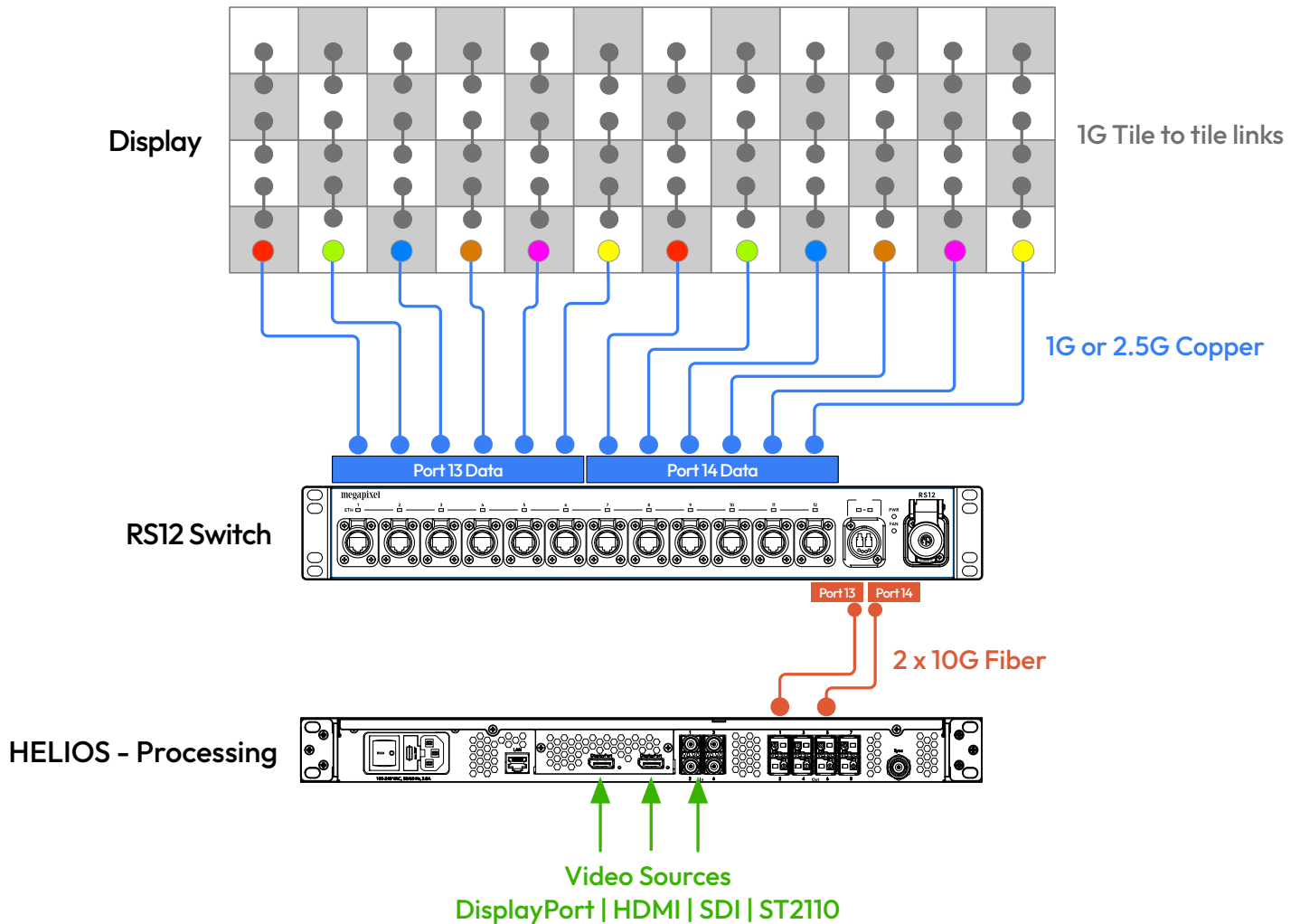

Figure 14: Basic system with dual 10G uplinks

NOTE: Always ensure data loads are balanced across switches in multi-switch HELIOS® systems. Similarly, dual 10Gb uplink systems should have balanced data loads.

The diagram on the following page shows the full connection detail for an RS12-based system, including output port capacity at 1Gbps and 2.5Gbps, fiber and copper connection types, and uplink port assignments. Footnotes detail throughput limits and tile manufacturer dependencies for 2.5G connectivity.

3.3 HELIOS® Connections

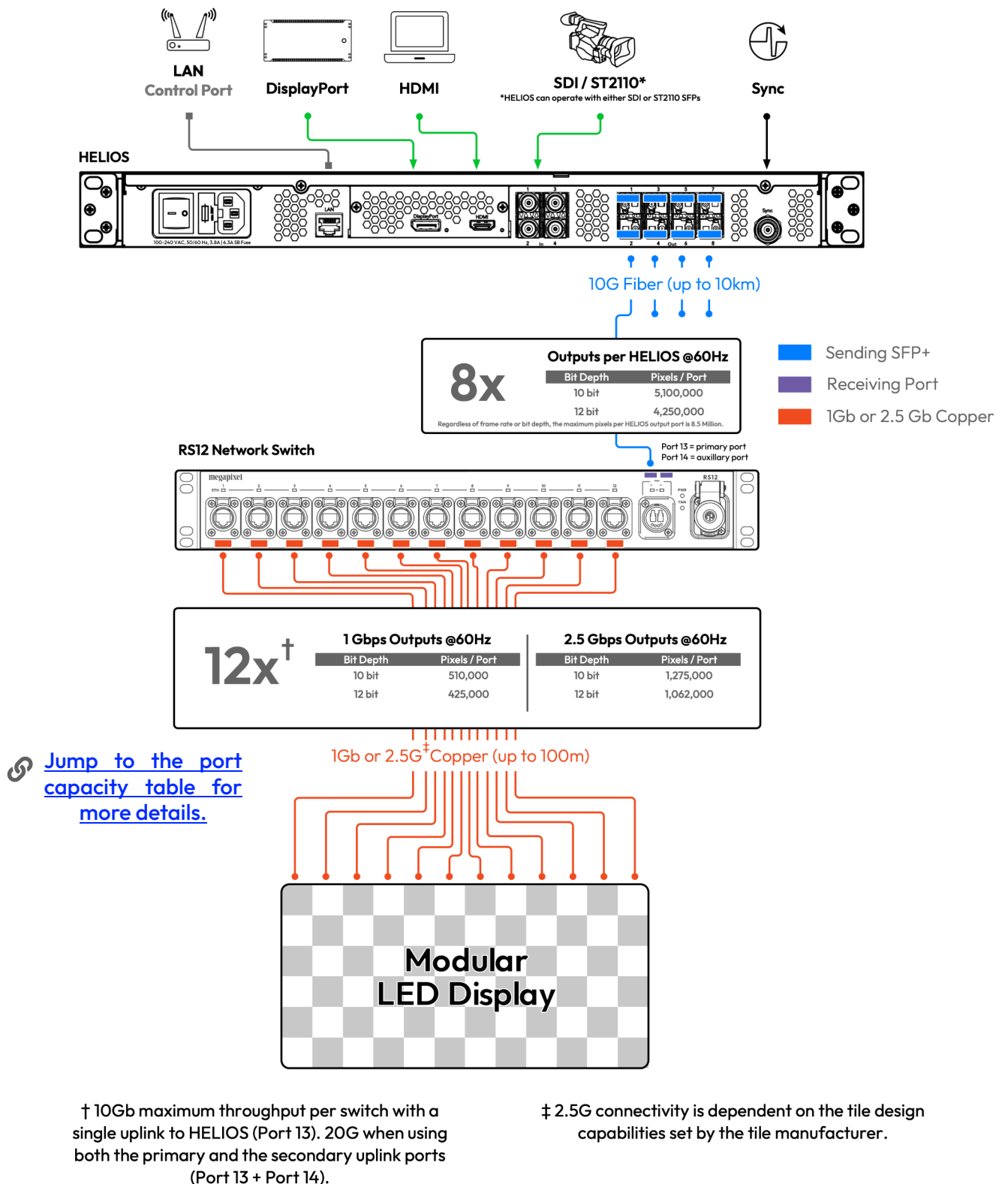

Figure 15: HELIOS® connections

TIP: For convenience or compatibility with wireless-only devices such as tablets, a wireless router can be attached to the HELIOS® LAN control port.

4 - Networking

4.1 Overview

To provide access to control the HELIOS® system, a LAN port is provided on the rear of the unit. This port provides access to the web UI. Once the client device (tech laptop) is on the same network as the HELIOS®, open a web browser and enter the IP address displayed on the front LCD of the HELIOS® Processor. In large systems, it is good practice to confirm that the device name at the top of the page matches the intended HELIOS® unit.

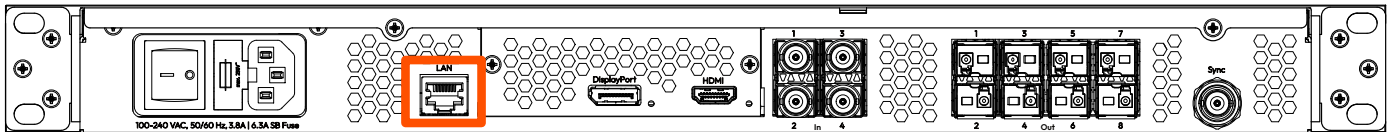

Figure 16: LAN Port

4.2 IP Addressing

The IP address of the HELIOS® is reported on the front display. Regardless of what the final network settings for the HELIOS® system will be, the web UI client must initially be configured to the network that the HELIOS® is on so that the web UI is accessible. Each device and operating system has slightly different ways to make these settings, please refer to the instructions of the particular device being used.

A HELIOS® that has been factory reset will be set to DHCP/Auto IP by default. This is the mode that should be used when operating the HELIOS® with a wireless router attached to the control port. If the HELIOS® has discovered a DHCP server, the HELIOS® will likely have a 192.168.XX.YY address. If it has not been served an IP address by DHCP, the HELIOS® will default to an automatic private address (169.254.XX.YY). If DHCP/Auto IP is the chosen mode, the web UI host device must also be set to DHCP to join the same network.

The HELIOS® can be configured to a fixed IP as well. If this is the desired mode, ensure both the IP and the subnet mask for the web UI host have been set to the correct range.

The IP address of the HELIOS® can be set using the front panel interface.

1. Press the encoder on the front of the HELIOS® unit, then turn the encoder to select **Settings**.

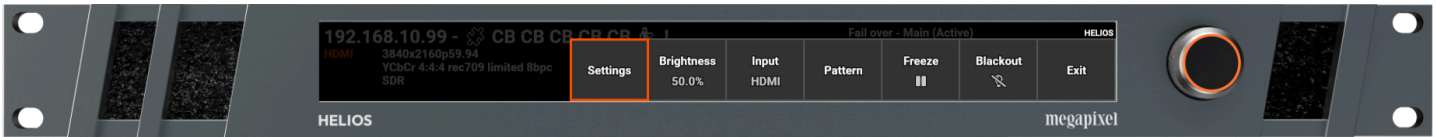

2. Select **IP Address**.

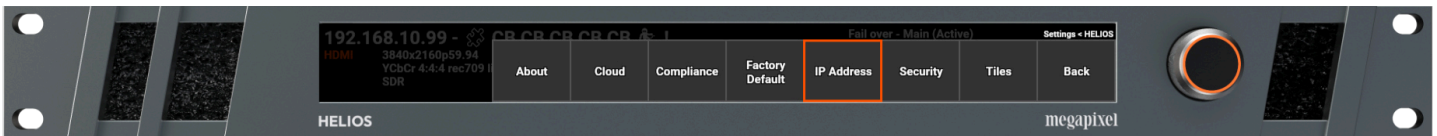

3. Choose between **DHCP** or **Static IP**, depending on the network that the HELIOS® needs to join.



4. Once the settings have been made press **Apply**.

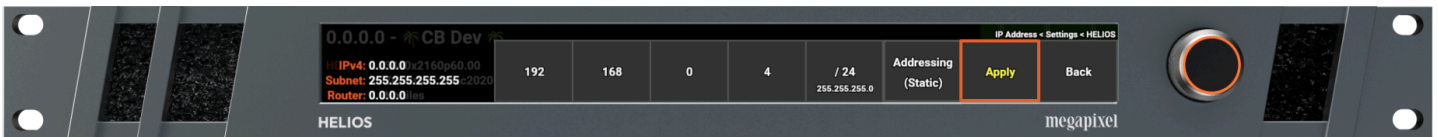

4.2 IP Addressing

The IP address of the HELIOS® can also be set using the web UI interface under **Settings > Processor Settings > Networking**.

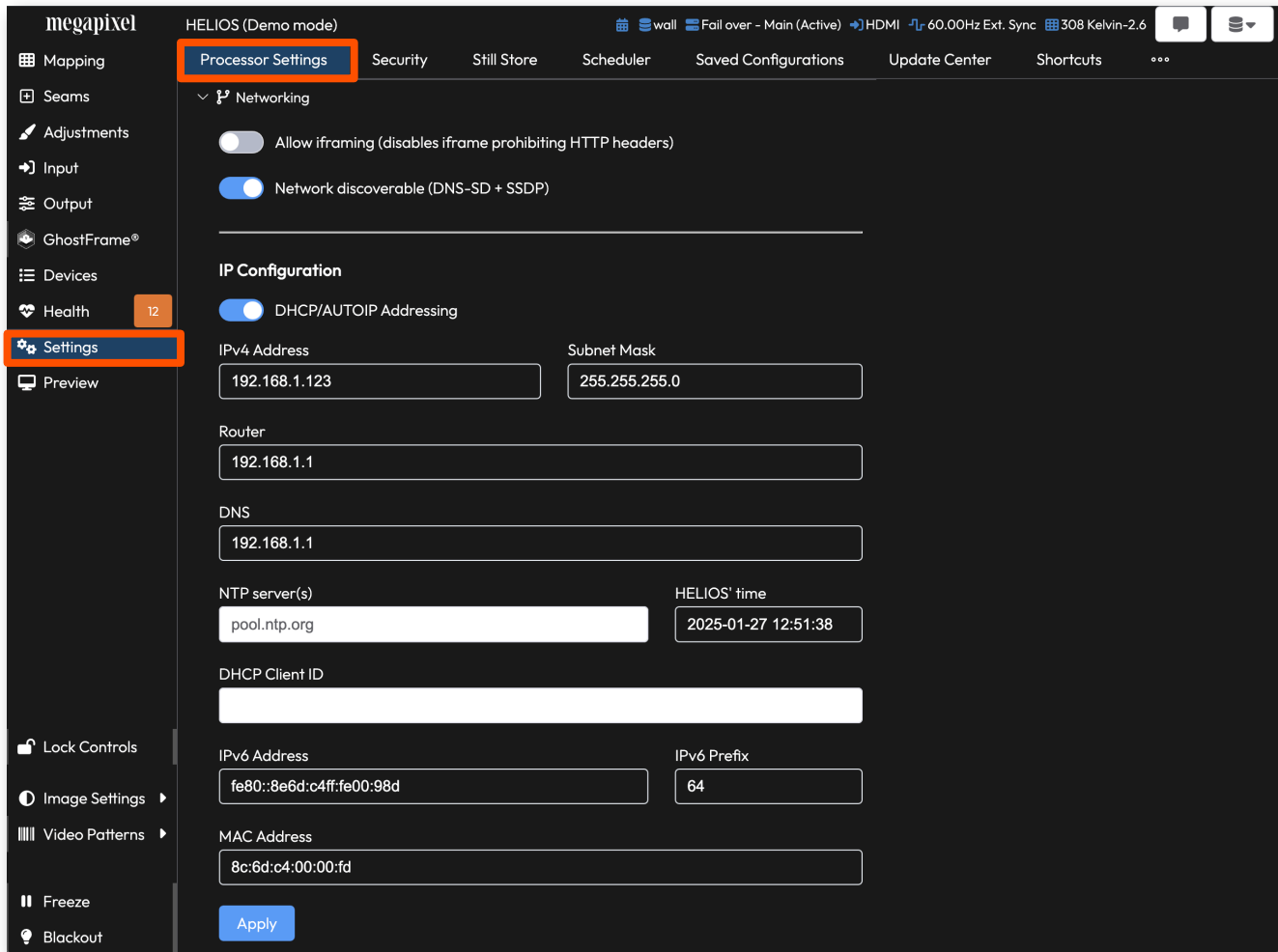
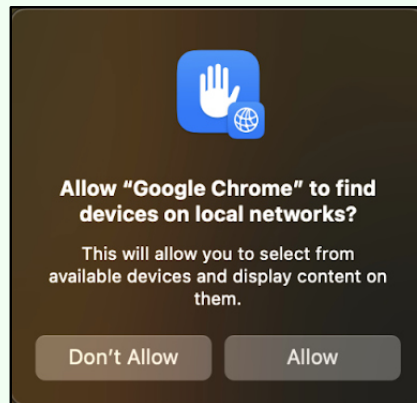

Figure 17: Web UI network settings

NOTE: To advertise a MAC address using DHCP Client ID, ensure that the MAC address is formatted with colons (XX:XX:XX:XX:XX:XX), otherwise the Client ID will be assumed to be a string.

4.2 IP Addressing

NOTE: After updating to Sequoia on Mac, a dialog box asks if the system should allow the browser access to devices on the local network. If **Don't Allow** is selected, HELIOS® will NOT be available on the local LAN!



To fix the issue, in the macOS, navigate to **Privacy & Security > Local Network** > Enable the checkbox for the browser in question.

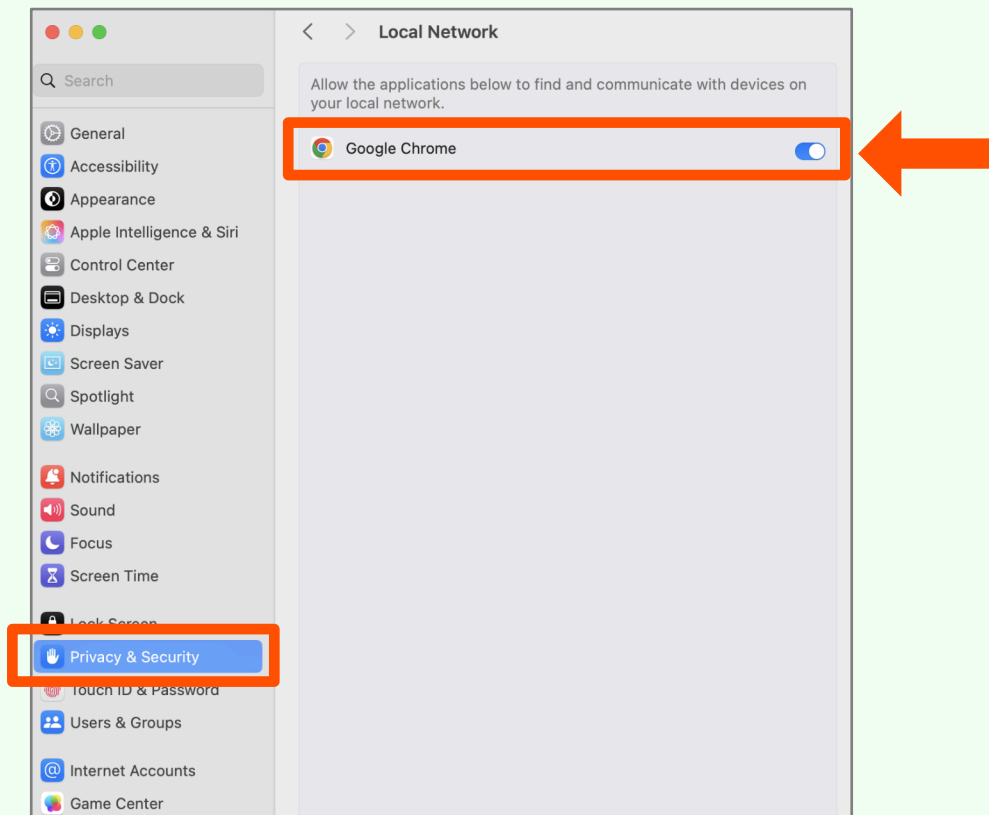

5 - Configuration

5.1 Overview

Prior to beginning to configure the system, a majority of the components of the system should be physically connected. The HELIOS® should be connected to at least one network switch and the switch should have panels connected.

The HELIOS® has two user interfaces; a front panel rotary encoder / push button interface with LCD display, and a web UI.

5.2 Front Panel UI

The front panel interface is targeted towards getting remote web UI access to HELIOS®. When the encoder is rotated (not pressed) the HELIOS® will cycle through four (4) data display pages. The fourth page (shown below) will display a QR code for the IP address of the unit.

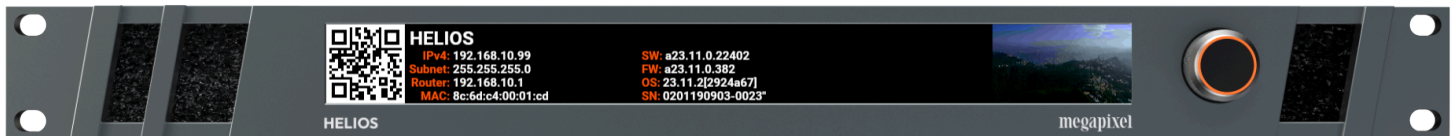

Figure 18: Front panel UI

The front menu also has a few other basic controls for settings and operation of the display. The front menu provides access to processor configuration options such as IP address, time, security, and preview access. To configure front panel settings, press the encoder, highlight the **Settings** menu option, and press the encoder to select the next menu item.

The Previews security mode used for controlling web UI previews (Allowed, LAN only, Blocked, or Disabled) is configured under **Settings > Security** on the front panel. See Section 5.11.1 [Security \(Advanced\) Previews](#) for more details.

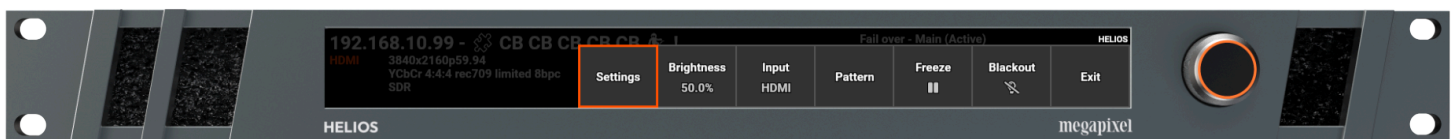

Figure 19: Settings menu

5.3 Web UI

The web UI contains all of the other controls that are needed for setting up a display system. The web UI configures the HELIOS® for the various supported video panels and provides controls to the input and output signal parameters such as selection of source, position, and color.

The previous chapter on Networking covers the settings required for both the HELIOS® and the device used as the web UI host. Having configured these settings correctly is a prerequisite. The web UI will not be accessible if this has not been done. The HELIOS® web UI runs remotely on any device capable of supporting Chrome or Safari web browsers. Shown below is the pane of the HELIOS® web UI.

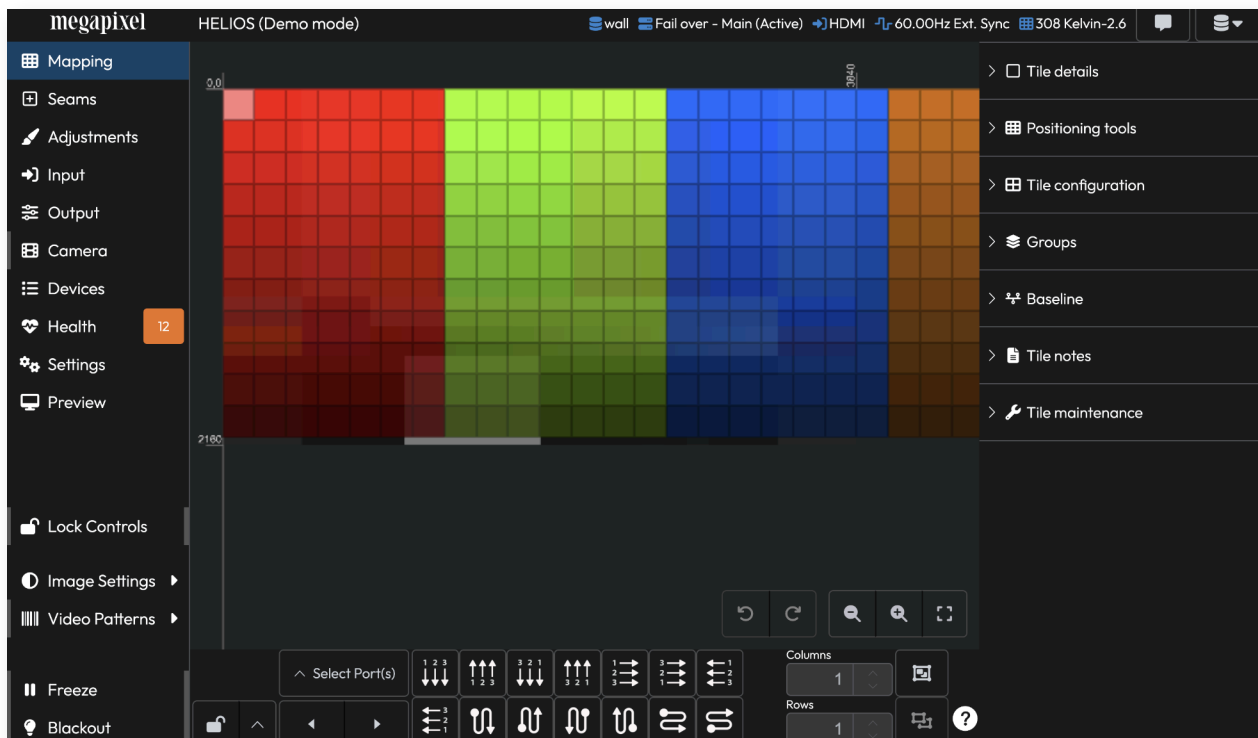

Figure 20: HELIOS® web UI

5.3.1 Processor Name

At the top left is the name of the processor. This can be changed in the [Processor Settings](#) pane.

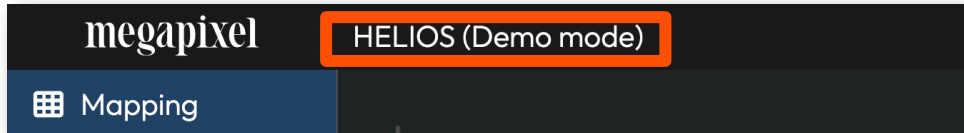

Figure 21: Processor name and Navigation bar

5.3.2 System Status Indicators

At the top right are the essential system status indicators for important system states such as redundancy, input signal, sync signal, and connected panels. Blue indicates good system health. Yellow is an alert, and red is a warning of a critical error. Look to **Devices** > Display Devices tab ([Section 5.8](#)) to discover more details about connected devices.



Figure 22: System status indicators

5.3.3 Feedback

At the top right of the interface is a button  to provide us with feedback.

Use the **Send (remote)** to submit the form. An active internet connection is required for the client device that is accessing the HELIOS® interface (the laptop or tablet the user is on). If no internet connection is available, use the **Save (local)** option to store the feedback on the tech laptop.

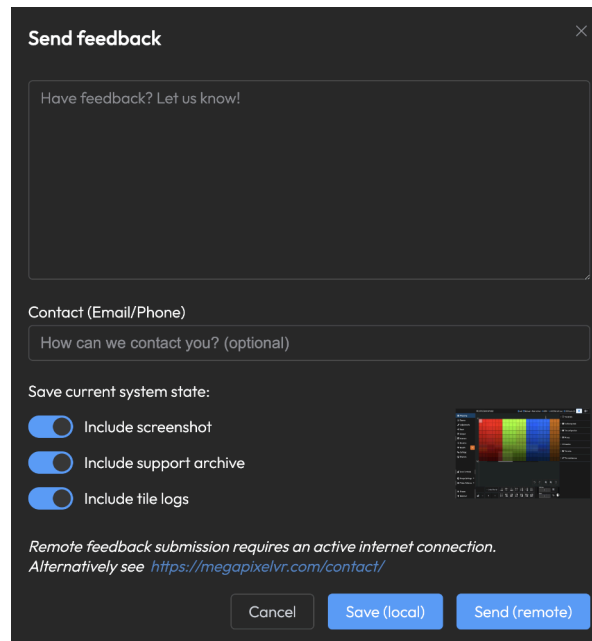

Figure 23: Feedback form

5.3.4 Command Palette

HELIOS® has a command palette for quick access to functions. Invoke the command palette with Command+K / Ctrl+K and start typing a command. HELIOS® will search and offer from all the available functions. In the example below 'bl' was typed. HELIOS® offers several options. Select one of the options to have it immediately execute the command. If **Blackout:Toggle blackout** is selected, HELIOS® will blackout. To turn blackout off, call up the command palette, Command+K / Ctrl+K, type 'bl' and press enter on the top item in the list to execute it. This time HELIOS® removes the blackout since the command is a toggle.

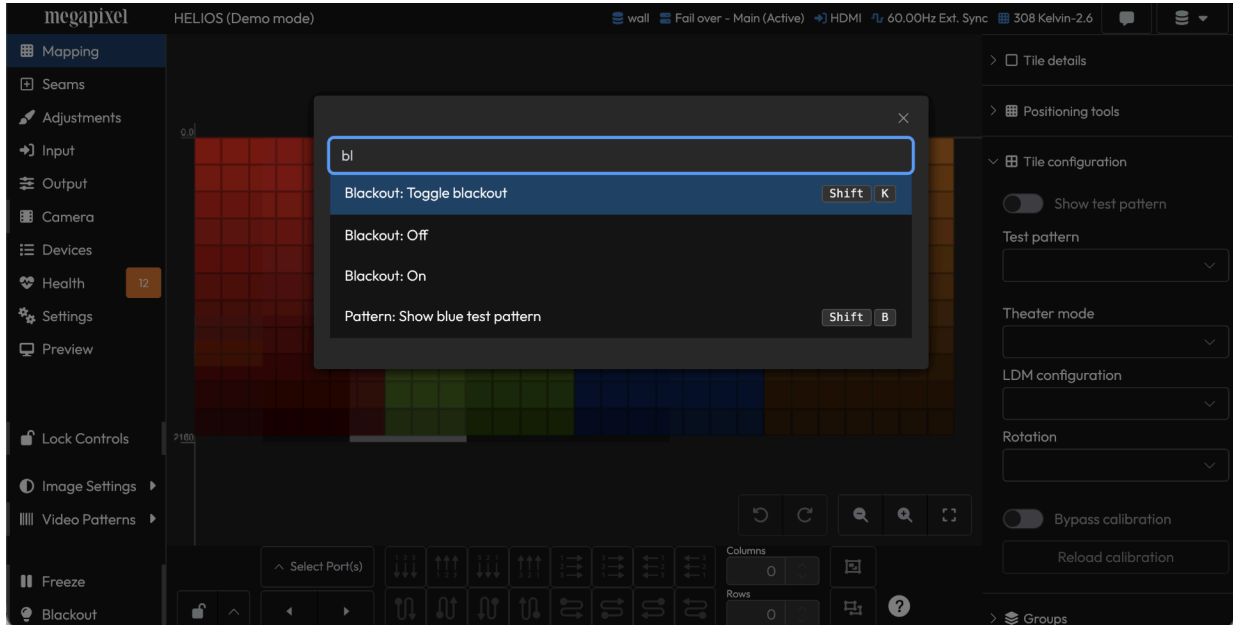



Figure 24: Command Palette

Command Palette Functions

- Toggle blackout/freeze
- Toggle/Set test patterns
- Toggle controls lock
- Toggle topology
- Download support
- Change theme
- Navigate to a page
- Switch input

5.3.5 Processor Stacks

When Stacking is enabled in **Settings > Processor Settings > Stacking**, a Stacks button  appears next to the Feedback button at the top right of the UI. The Stacks button opens a window that displays all available processors and the Stack each belongs to. This feature helps identify the system status of processor Stacks and gives confidence that backup units are available. Select the IP address to the right of the processor name to open the web UI page of a processor. Visit the section on [Stacking](#) settings and [Appendix F](#) on Redundancy to read more about how this feature is used.

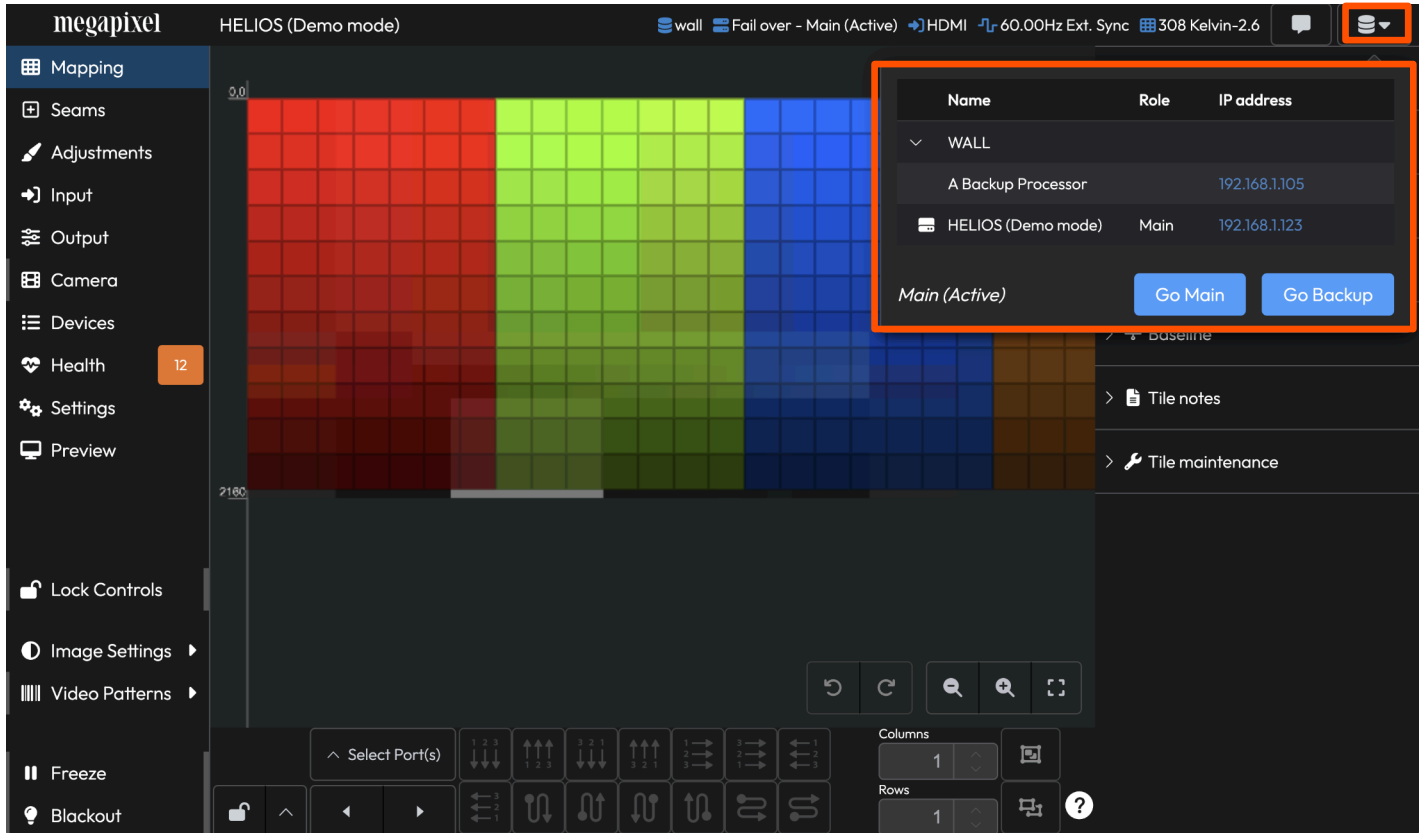

Figure 25: Processor Stacks

5.3.6 Global Controls

1. **Lock Controls** — Enable this to prevent accidentally triggering any of the controls below it.
2. **Image settings** — contains the **Brightness**, **Gamma**, and **Color temperature** controls (pictured above). These types of sliders can be found throughout the web UI. Once they have been selected with a mouse click, sliders such as these can be controlled with a mouse wheel.

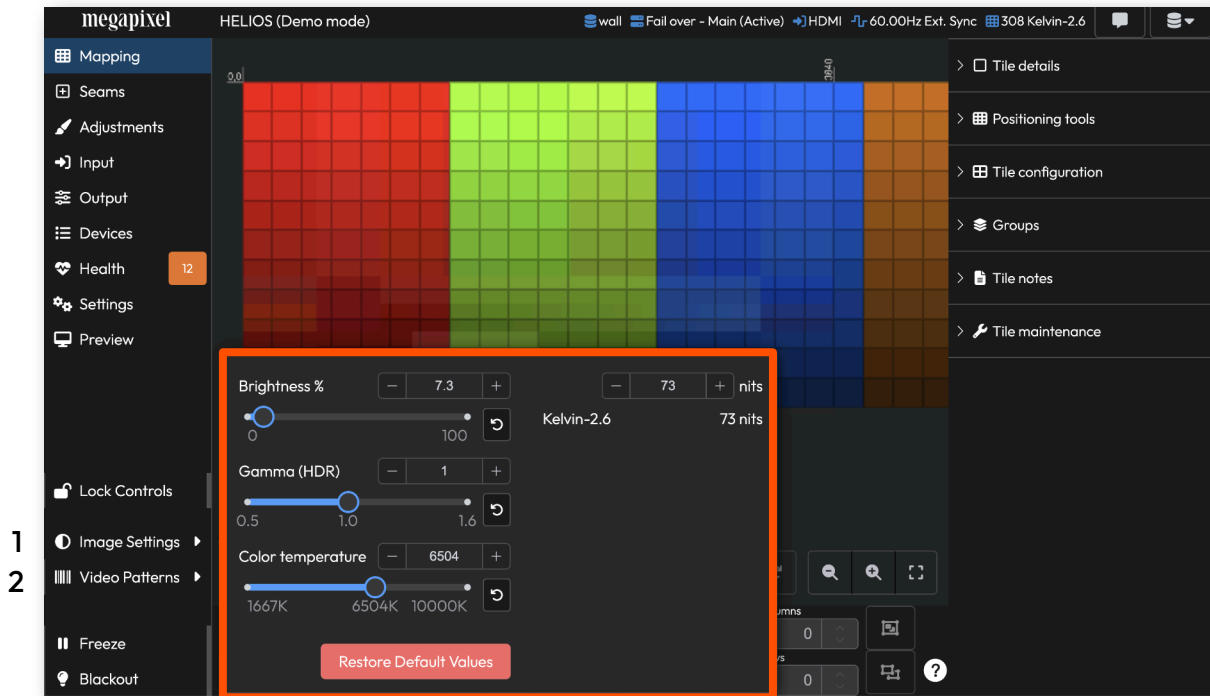

Figure 26: Global controls

NOTE: By default, systems with multiple display device types limit the maximum luminance. This behavior can be overridden. See [5.6.11](#) Limit to lowest tile max section for more details.

Image settings (Advanced) — With Advanced Mode enabled, the Duv value of a color can be set. This ensures a precise color that is not possible with CCT values alone.

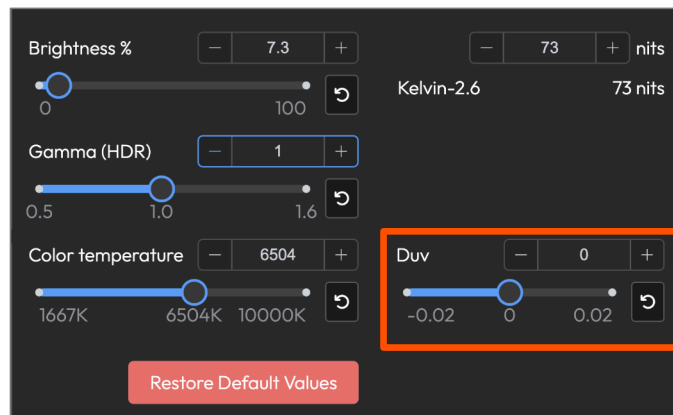

Figure 27: Duv control in Advanced Mode

5.3.6 Global Controls

3. **Video Pattern Selection** — Video patterns override video inputs. A dropdown menu provides a selection of HELIOS® generated patterns.

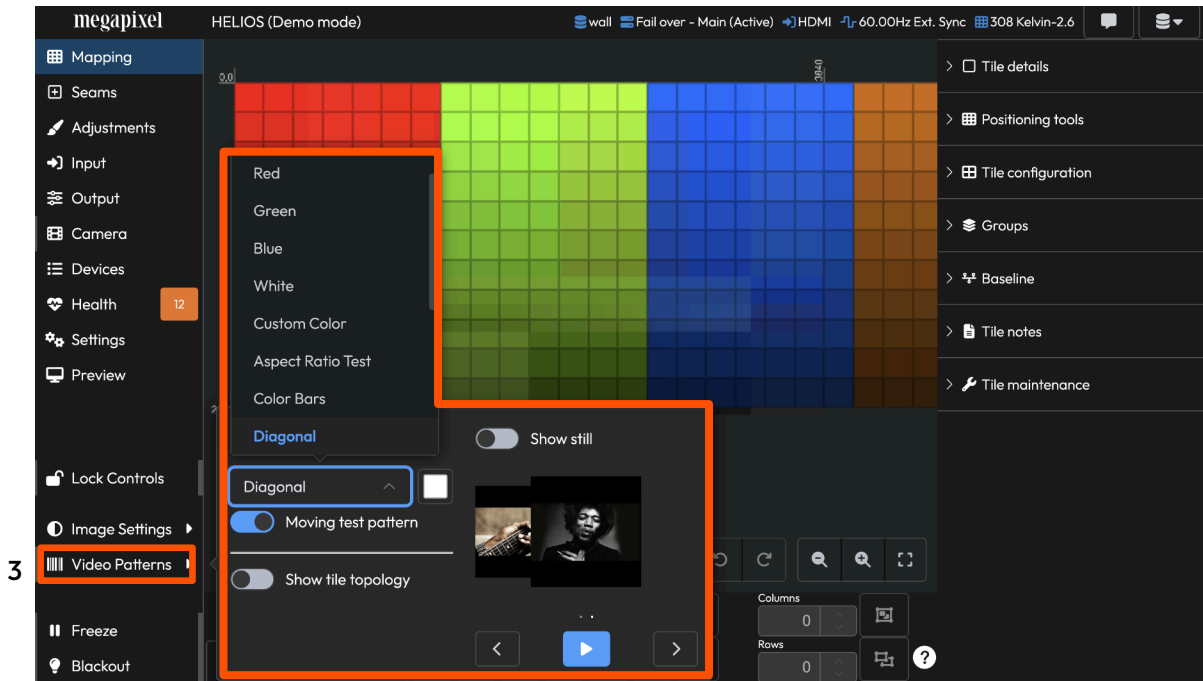

Figure 28: Video pattern selection

Custom color patterns — Some patterns can be custom colored. When custom color is available for the selected pattern, select the color box to the right of the pattern selection dropdown menu to open up a color picker.

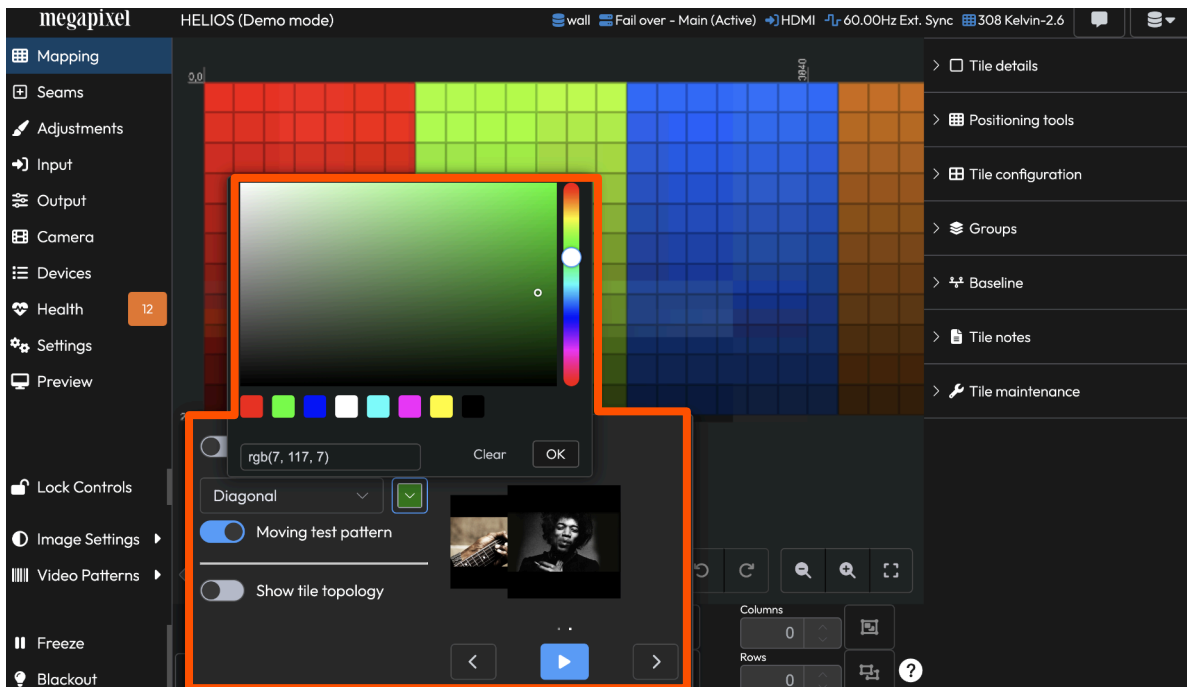

Figure 29: Video pattern color picker

5.3.6 Global Controls

Once a video pattern is selected, a yellow border will surround the input raster. This indicates that the global video pattern is overriding the video input.

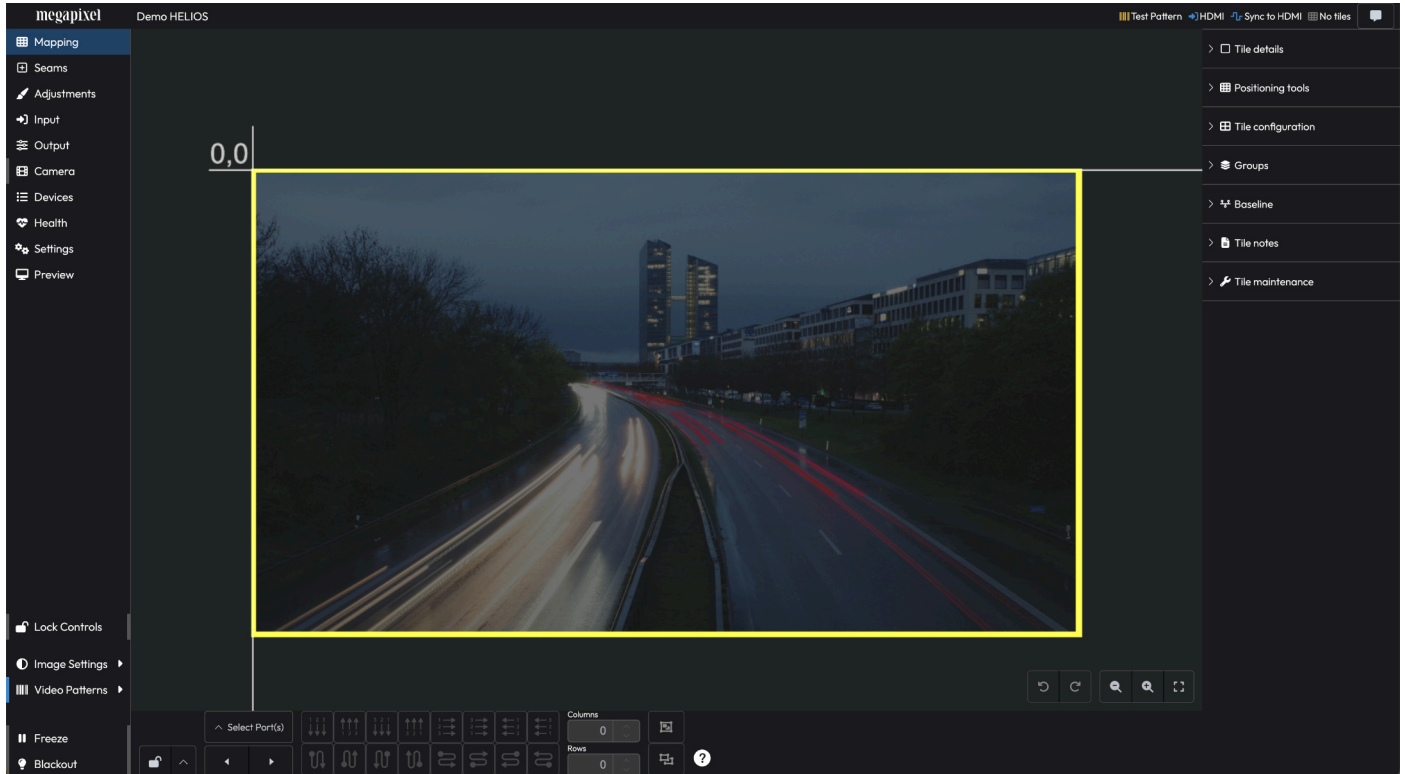

Figure 30: Yellow border indicates video pattern is enabled

5.3.6 Global Controls

Still images — Show stills that have been stored on the HELIOS®. Select an image from the carousel and press the playback triangle to display the selected image. See the [Processor Settings > Still store](#) pane to store and manage images. When **Show still** is enabled a small yellow **Show Stills icon** is visible on the top of the app (see orange arrow below).

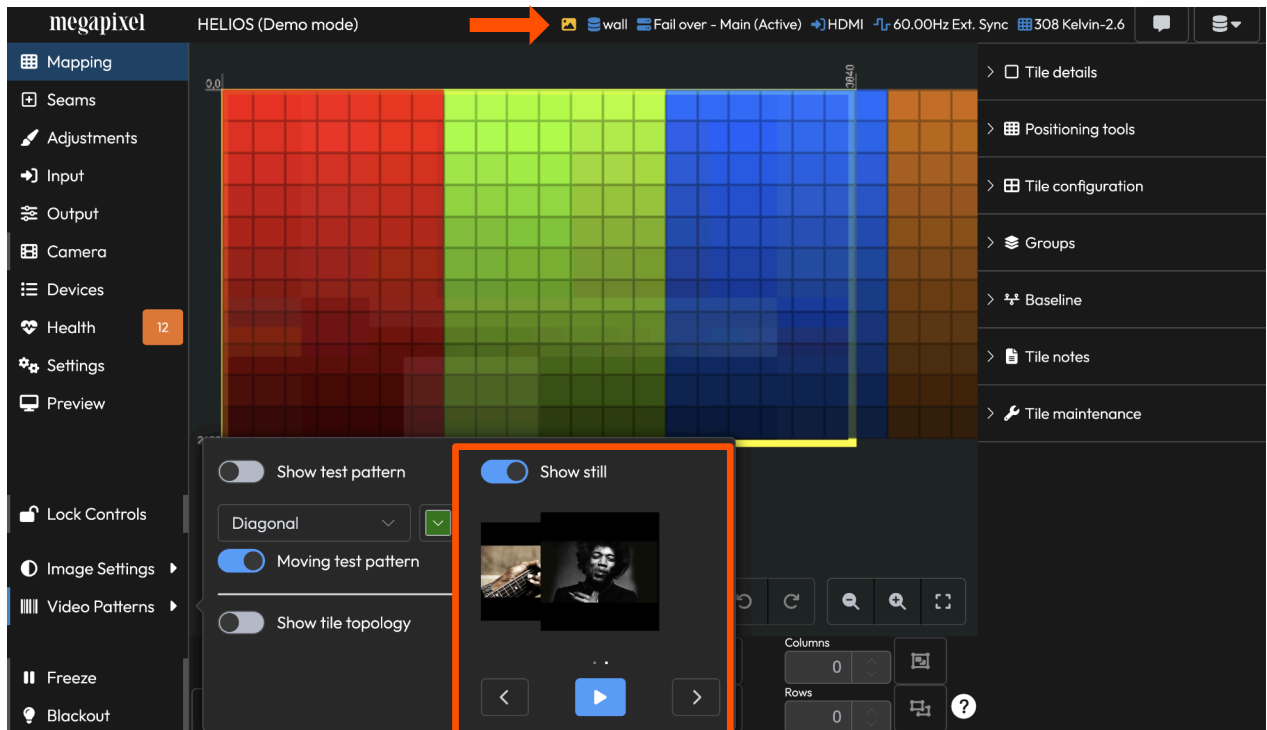

Figure 31: Show stills

5.3.6 Global Controls

The bottom two options are controls for freezing or blacking out the output.

Freeze — will continuously display a still image of the last input frame at the time the **Freeze** button was pressed. This feature is convenient to use when the input signal must be interrupted, and the live display can show a still image such as a logo. To use this feature, display the desired image and press the **Freeze** button. The input signal can now be interrupted and the HELIOS® will continue to display the still frame grab. When it comes time to resume, display the same image again with the connected playback device and toggle **Freeze** off to resume live playback.

Blackout — is a black generator that ensures all LEDs are completely off. This feature is ideal to use for situations when panels need to be placed on standby with power use at a minimum. HELIOS® compatible tiles all have a low power mode that can be set to enable immediately on blackout, one (1) minute after blackout or after five (5) minutes of blackout. See [Settings > Tiles > Low power mode](#) to configure. When low power mode is enabled a green leaf shows up next to **Blackout**.

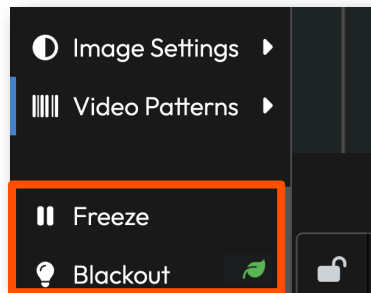

Figure 32: Freeze and Blackout

5.3.7 Canvas Lock

When changes on the mapping pane and the inputs pane are complete, it is good practice to lock the panes to prevent any unintentional changes. The lock mechanism locks and unlocks the canvas functionality simultaneously on both the mapping pane and the inputs pane.

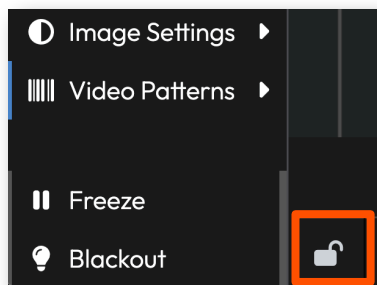

Figure 33: Canvas Lock

5.3.8 Keyboard Shortcuts Menu

Always available with the press of ‘?’ on the keyboard, the shortcuts menu provides a list of functions that have been assigned to key combinations. This pane is also available on the **Settings Pane > Shortcuts** tab.

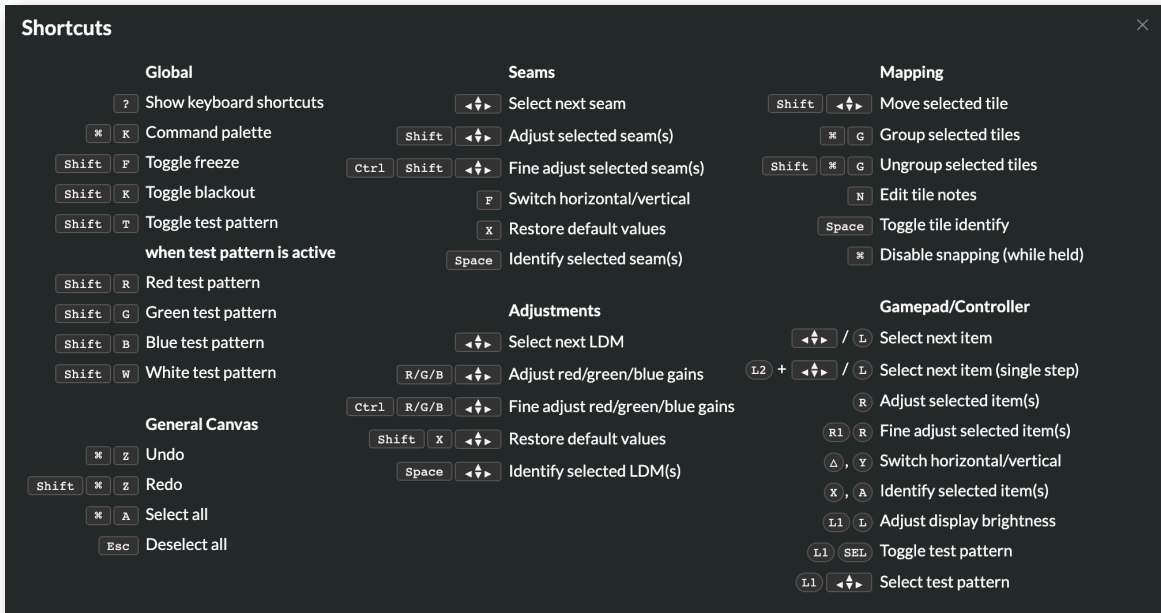

Figure 34: Keyboard Shortcuts

5.3.9 Advanced Mode

Throughout this user guide several features are marked as **Advanced**. This means that the feature is hidden by default and can be accessed by enabling **Advanced Mode**. When **Advanced Mode** is enabled, HELIOS® reveals numerous hidden features that have not been selected for general release. The **Advanced Mode** toggle can be found under **Settings > Processor Settings > Advanced**.

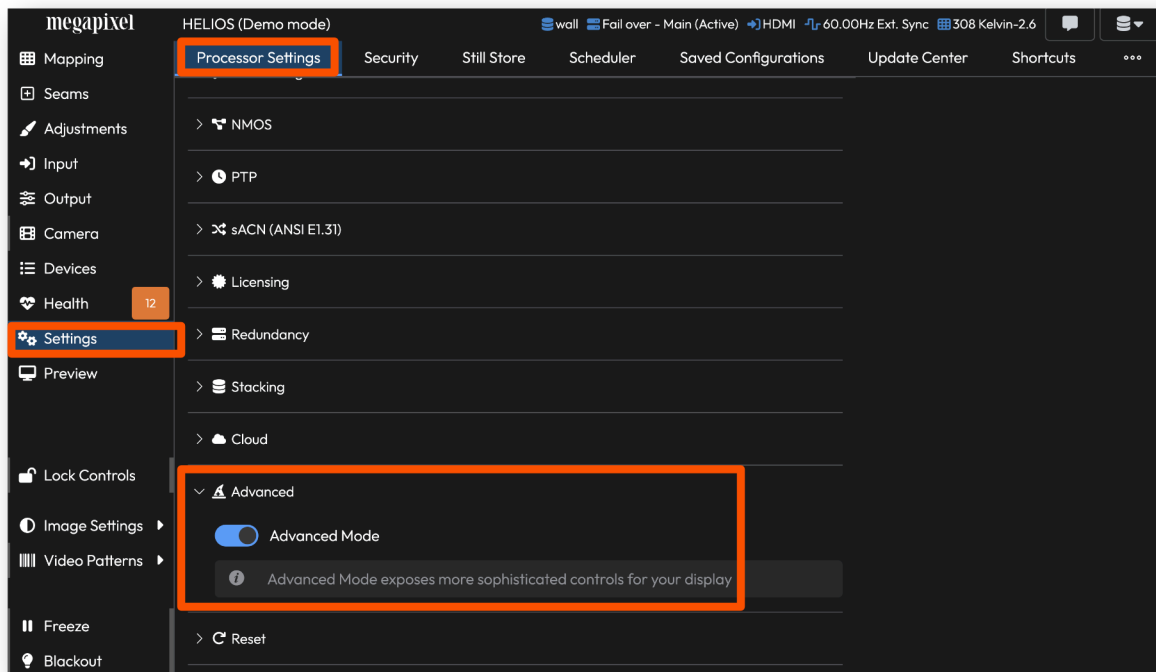

Figure 35: Advanced Mode toggle

5.4 Creating Maps

The HELIOS® uses a map to determine which segments of the inbound raster to consider as an ‘active pixel region’. Areas of the inbound raster that are not associated with display fixtures, are never transmitted to the system. If only two fixtures are mapped, only two fixtures worth of panel data is transmitted.

If tiles have been discovered, they will be placed on the map. By default, when panels are discovered, they are all collected in the top left (0,0) position. HELIOS® does not support offline mapping; only automatically discovered tiles can be mapped.

The thin light gray line on the outside of the tile region marks the boundaries of an 8192 x 4320 pixel space. It can be used as a guideline for placement, but maps do not need to be constrained to it. On a layer below the colored panel icons is a preview of the selected input (or a gray rectangle if the input is unavailable) that represents the inbound signal’s raster area. It will only be visible if the input signal raster is set larger (using the Input pane) than the space occupied by the tiles. In the example below it is slightly oversized to the panels.

The mapping tools at the bottom of the page are used to move the panels into the positions that they occupy in the physical system. Select a group of panels, define the columns and rows that they should be arranged in, then select the cable order. When the cable order icon button is pressed, the selected panels will be re-ordered. HELIOS® can undo and redo maps in case something did not turn out as desired. Panel locations can also be adjusted manually by drag and drop or by typing the desired X and Y coordinates.

Display panels are tinted according to the network switch that the panels are connected to (Red = 1, Green = 2, Blue = 3, etc.). In the example below the system has been cabled in columns with seven columns per port. There are four network switches in the system example below.

There are three (3) ways to pan the canvas:

- Hold the middle mouse button while moving the mouse
- Ctrl/shift + right mouse
- Ctrl/alt + left mouse

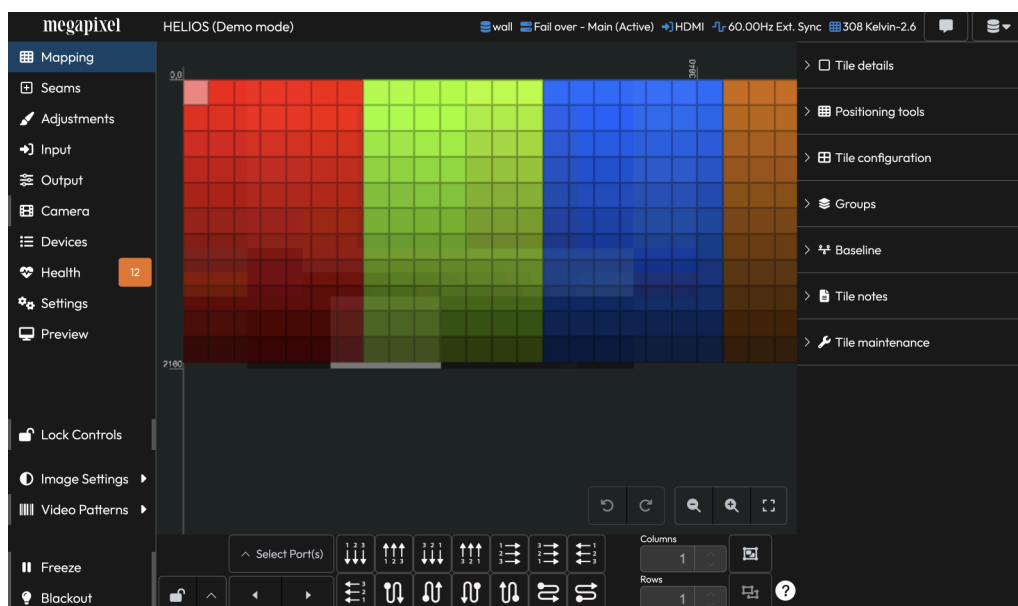

Figure 36: Mapping pane

5.4.1 Mapping Pane

The right side of the mapping pane has accordion menus with tools for mapping and configuring tiles. Select at least one tile to see information about it.

Tile details

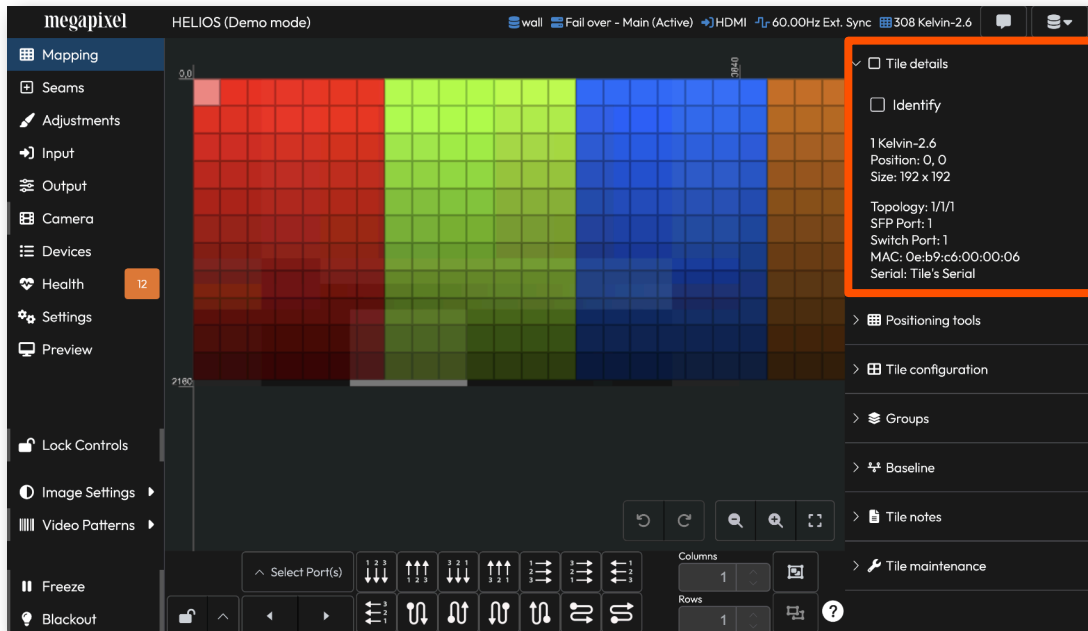

Figure 37: Tile details

Directly below, is an **Identify** checkbox. When this is checked ON, selected tiles will be highlighted in the system (blue dot on tile in the user interface). The Identify behavior has two modes (1) **Rear indicators** only or (2) **Front identify & Rear indicator**. On the **Processor Settings** tab in the **Tiles** accordion, a dropdown menu offers these two choices.

The **Show Indicators** toggle on the **Settings > Processor Settings** pane, enables/disables the rear tile run time indicators (i.e., solid blue, red, etc.). The **Identify** function operates independently, it will be available even when this setting is disabled.

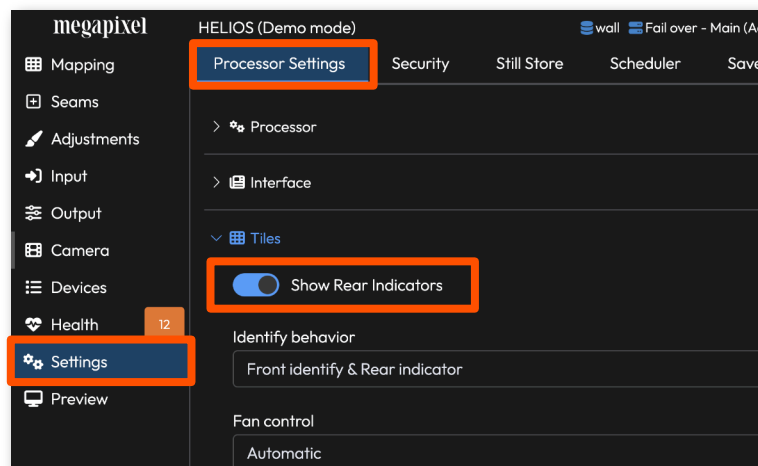

Figure 38: Tile Identify behavior

5.4.2 Positioning Tools

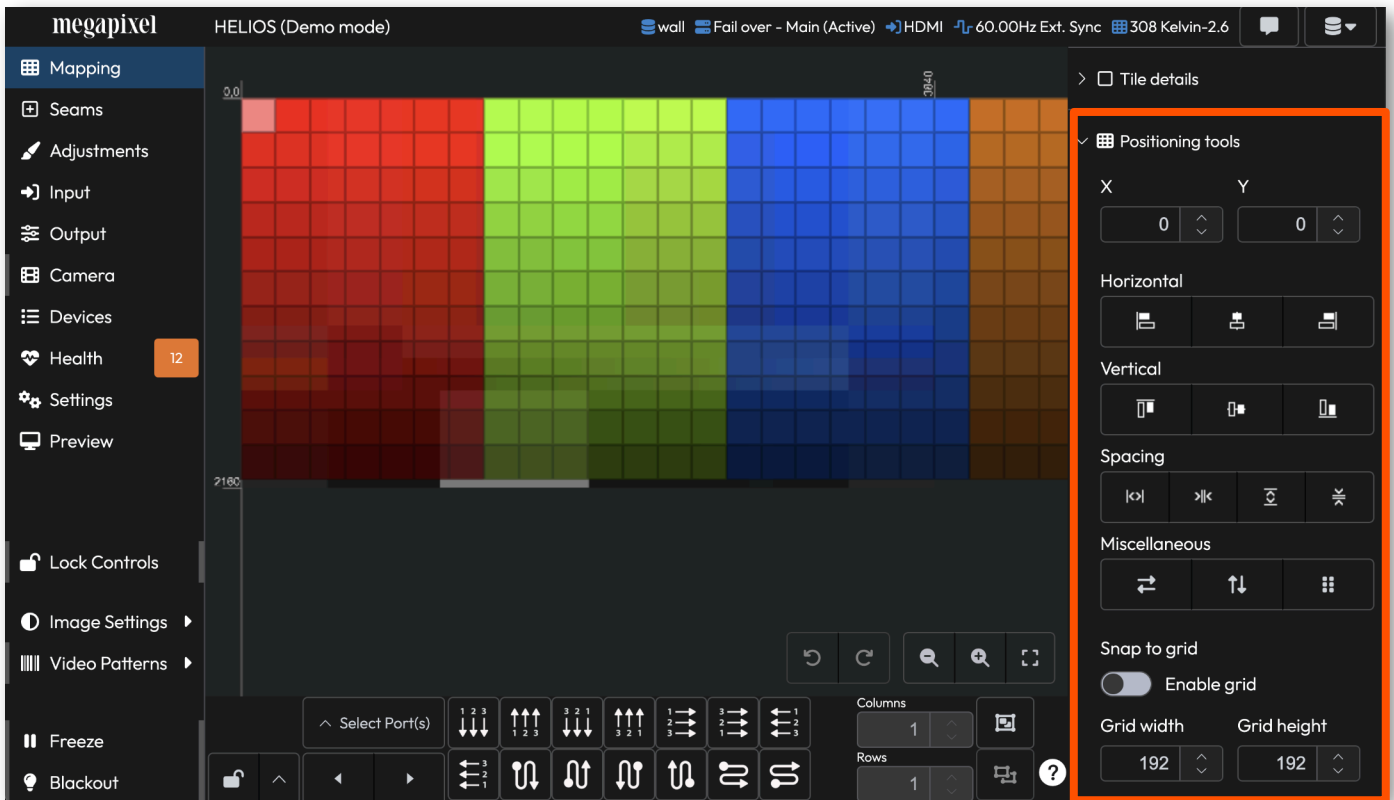

Figure 39: Positioning tools

The mapping tools section contains alignment and spacing tools to aid in manual positioning tiles on the map.

Snap to grid — A grid with a snap function is available to help keep manually positioned tiles aligned. Set the grid to the pixel size of the tiles being mapped to ensure accurate positioning of all tiles.

5.4.3 Positioning Tools (Advanced)

CAD style selection — A toggle can help make the selection style behave in a more familiar way. When this mode is ON, dragging from right to left (←) only selects the tiles inside the drag boundary zone. When this mode is OFF the drag right to left (←) action selects all tiles that the drag boundary touches. Regardless of how CAD style selection is set, dragging from left to right (→) always selects everything that is touched by the selection box.

Layout merge ports — There are some cases where systems have uneven heights between tile columns. When enabled, the mapping pane will place tiles continuously along the topology path without breaking (the usual default behavior). With the **Layout merge ports** toggled off, the mapping pane will start a new column/row at the end of each string.

Snap to tile edges — Have the Mapping pane constrain tile placement to the edge of nearby tiles. This tool acts like a magnet snap when tiles are being placed on the map and they approach other previously placed tiles.

5.4.4 Tile Configuration

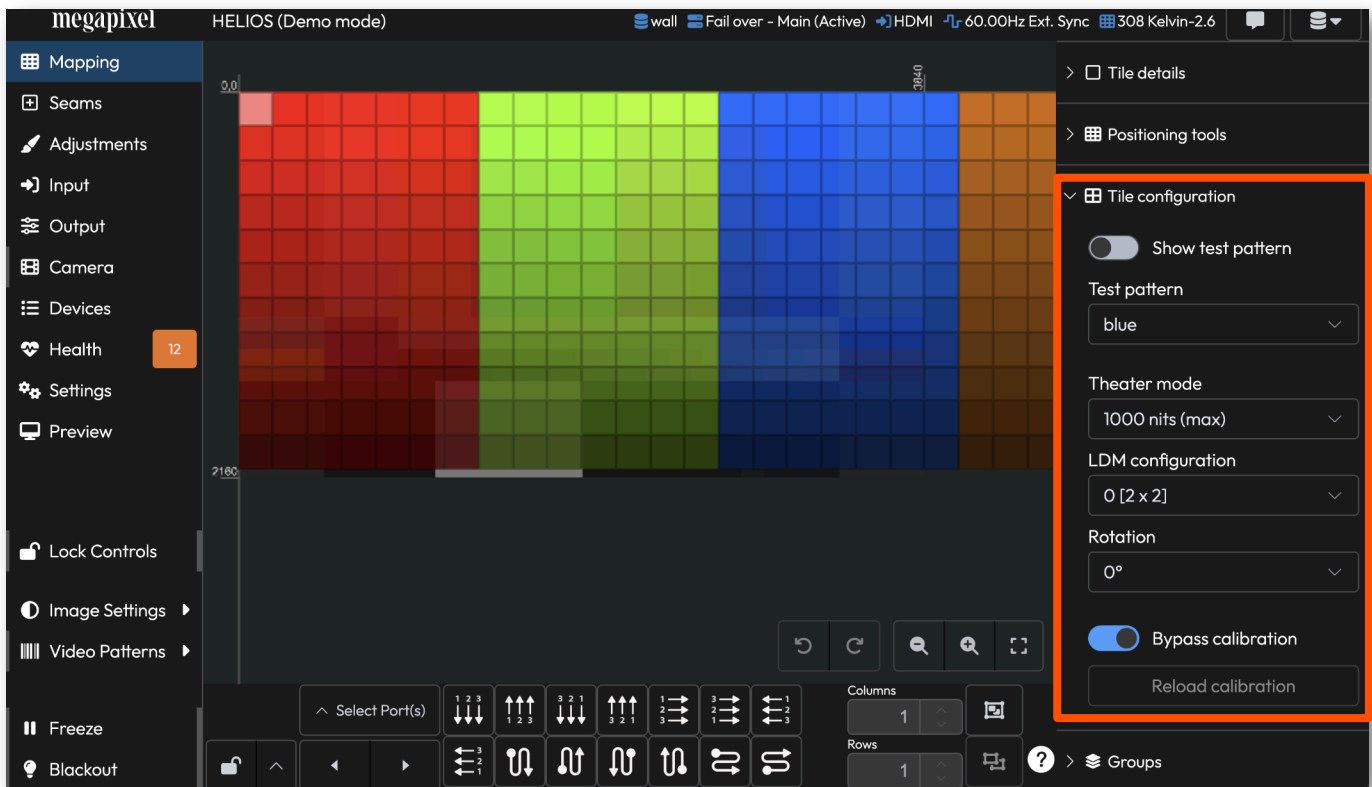

Figure 40: Tile configuration

Test pattern toggle — Select the tile test pattern desired and then choose to enable it with the toggle. These patterns are tile patterns that each individual tile calls up from onboard memory. As such, the list of available patterns can vary based on the tile(s) selected. Tile test patterns are different from the **Video Patterns** located above **Freeze** and **Blackout** that send a video signal from the HELIOS® to the entire array of tiles.

5.4.5 Tile Test Patterns

Pattern Name	Function
Black / Red / Green / Blue / White	Solid color test patterns
Counters	Total run time along with various diagnostic counters to help with troubleshooting
Diagonal Lines (moving)	A pattern of moving white lines
Gradient (moving)	A moving gray gradient
Grid	A crosshatch of white lines on a black background
LDM Details	Batch and serial number information for all the LDMs in each tile
LDMs	ID numbers on each LDM with boundaries of each LDM marked with a cross at each corner
LED Batch info	Manufacturing information for the LEDs
Tile Details	Detailed information for each tile (tile type, firmware version, serial number, PX1 number, MAC address, thermal info and fan info, where applicable)
Topology	Connection information regarding each tile. At the top of the test pattern is a numerical code that corresponds to how the tile is connected to the system (HELIOS® Port / Switch Port / String position). A blue arrow indicates the direction of the data flow to the next tile

5.4.5 Tile Test Patterns

Theater mode — A special low light level calibration configuration. If a tile has been calibrated for special low light situations, the tile will utilize full bit-depth at the selected lower luminance. If a tile does not have this additional calibration file, it will not support theater mode and will default to showing maximum luminance.

LDM arrangement — A single tile type can sometimes have multiple LDM configurations. If the tile type being used supports this, the dropdown menu will list them here.

Rotation — Rotate the video being displayed on a tile so that the tile can be physically installed at a rotated angle but still display right side up video. Keep in mind that rotated tiles may not look the same as other non rotated tiles. LED panels with vertically stacked diode SMDs are especially affected by rotation changes to their viewing angle.

NOTE: Rotation affects GhostFrame®. Rotation will generally result in significantly reduced capability. In some cases there will be no GhostFrame® stream/slice capability.

GhostFrame® Opt Out — When GhostFrame® is enabled, the Opt Out controls appear. These controls enable GhostFrame® to be turned on/off on a per panel basis. The dropdown menu to the right of the toggle assigns a video stream for the tile to display instead of GhostFrame®. This feature is used to isolate GhostFrame® to on-camera tiles. A wall in front of the camera can be displaying GhostFrame® with tiles to the side opted out to showing only the human visible stream.

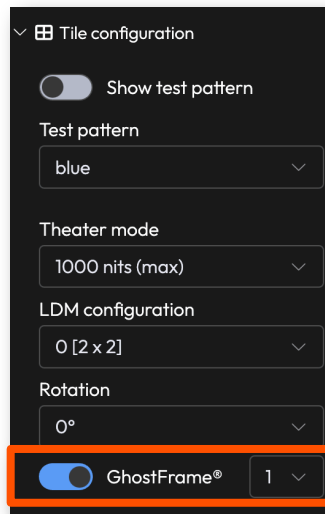

Figure 41: GhostFrame® Opt Out

Reload calibration — Reload calibration is useful if an LDM has been replaced and calibration data needs to be reloaded.

Bypass calibration (Advanced) — This toggle is available as an advanced function for rare cases where tile calibration data is suspect. Turn the toggle on to temporarily disable tile uniformity correction and color space retargeting. This setting does not persist after reboot.

NOTE: Not all tiles are designed to run for an extended period of time in full white with calibration bypassed. Please consult your tile manufacturer's operating instructions.

5.4.6 Tile Groups

Tile groups allow sections of tiles to be adjusted independently from the rest of the display. This is commonly used for systems with multiple independent displays.

Creating and managing groups:

- Create a group — select tiles on the map, then press Command/Ctrl + G
- Ungroup — press Shift + Command/Ctrl + G
- Add or remove tiles — use the **Add to Group** and **Remove from Group** icon buttons at the center bottom of the Mapping pane

How grouped tiles appear:

- The group boundary is outlined in white on the map
- The group name appears overlaid on the tile area
- Groups are listed as they are created under the **Groups** accordion on the right side of the Mapping pane, and are also accessible in the Seams and Adjustments panes

To edit tile positions within a group — double-click a group on the map to edit the position of individual tiles within it.

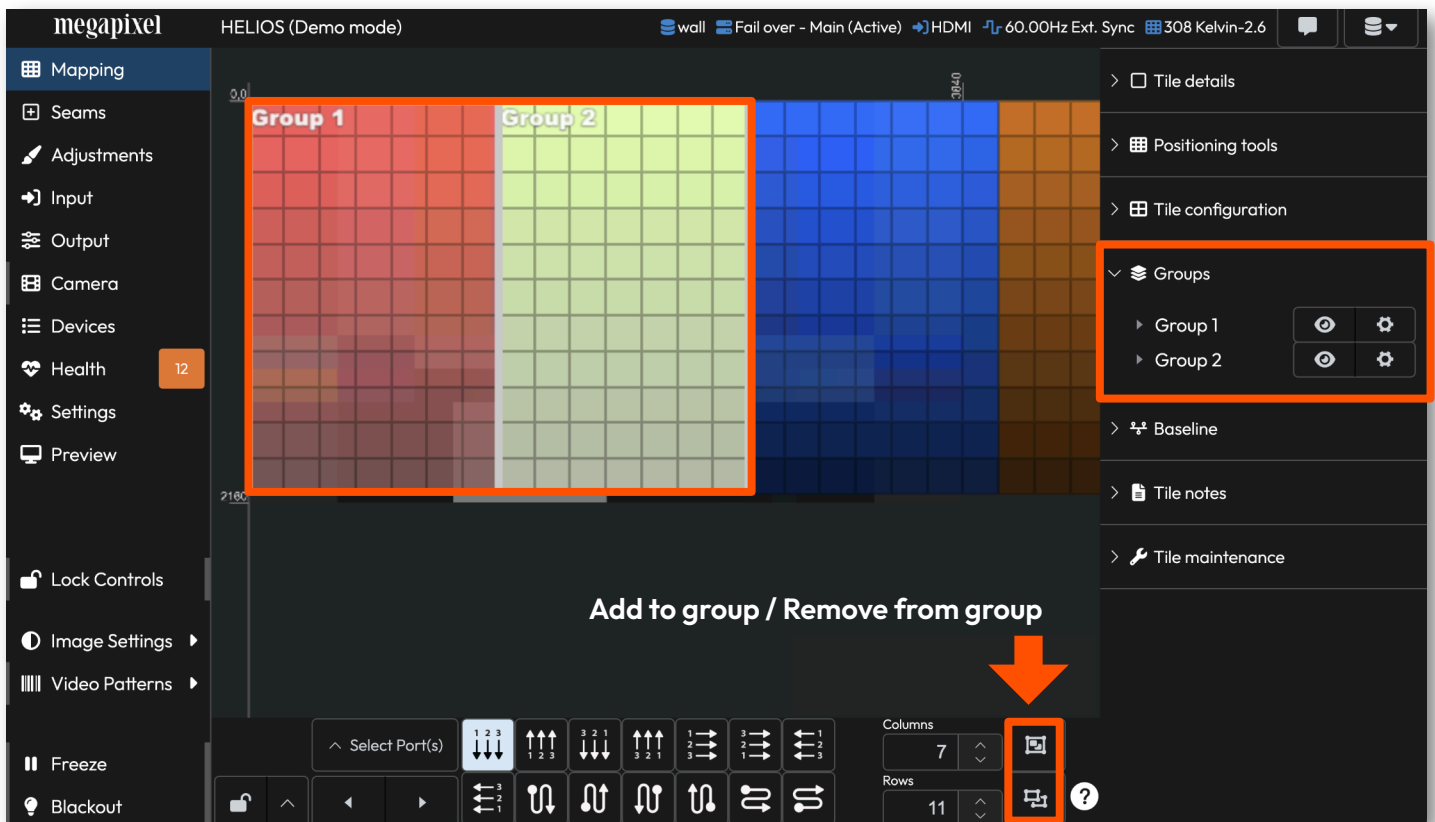

Figure 42: Tile groups

NOTE: When using groups with **Stacking**, groups replicate across the stack. All HELIOS® processors within the same stack should have the same groups and group settings.

5.4.6 Tile Groups

The **Tile Group Accordion** lists each group and quantity of the tile type in the group under a disclosure triangle. Click on the tile quantity line to select those tiles in the map. **Groups** can be re-ordered by dragging the group name to the desired position within the accordion. Next to the group name is a group **Visible on canvas** button to hide and show groups. A **Group settings** icon button opens the settings window for the group (see the next section for details).

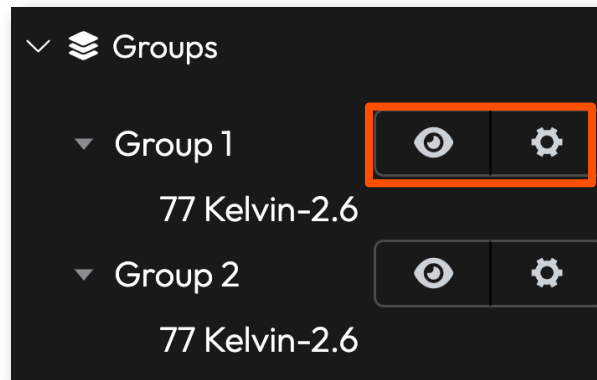

Figure 43: Tile group settings

Tile Group settings are also available by right clicking on a group directly in the **Mapping** pane.

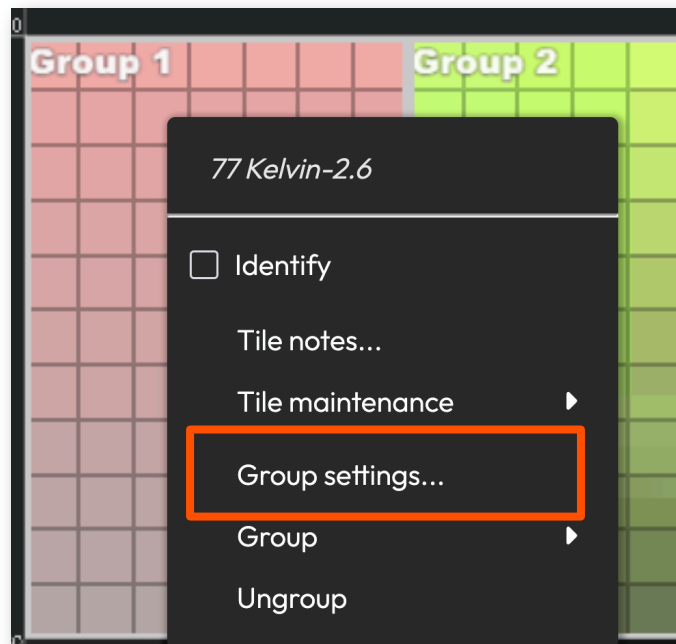

Figure 44: Tile Group settings in context menu

5.4.6 Tile Groups

The tile group control window contains the settings for each group. Click on the group settings button (shown on the previous page) to open the tile group control window. Group adjustments on tiles require tile firmware to be updated to version 22.04 or higher. The firmware update enables tiles to respond to the HELIOS® gains controls.

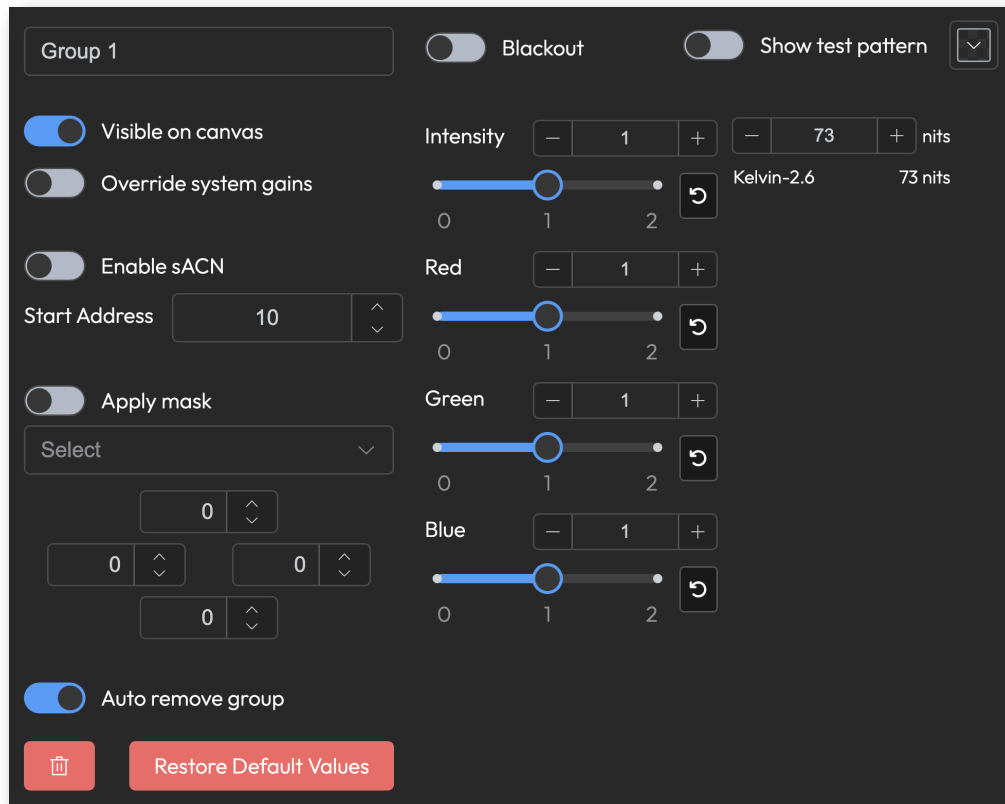

Figure 45: Tile group controls

Group name — By default, HELIOS® names groups with the word **Group + n** (an auto incrementing number). The name can be changed here.

Blackout — Enables Blackout for the selected group of tiles.

Show test pattern — A toggle to enable/disable a solid color pattern override.

Visible on canvas —  A toggle to show/hide the tile group on the system canvas. This is the same as using the visibility button .

Override system gains — A toggle that gives priority to tile group gains (**Intensity**, **Red**, **Green**, and **Blue**). With this toggle enabled, the tile group gain settings are absolute, the group of tiles operates independently to the rest of the system. Global blackout overrides these group gains.

NOTE: With **Override system gains** enabled, the gains controls (Intensity, Red, Green, and Blue) can cause visible clipping of tile calibration!

5.4.6 Tile Groups

Enable sACN — A toggle to enable remote control of a group via the sACN protocol. sACN functionality must also be enabled in the **Settings > Processor Settings**. With sACN enabled, channel assignment values appear in brackets in front of the name of each control. In the following example, [10] is the sACN channel for Intensity control of the group. This channel assignment is defined by the **Start Address**. Each new group is by default assigned the starting address of [10]. If individual sACN of groups is desired, manually increment the starting address to the next available sACN channel. See the sACN section under **Settings > Processor Settings > sACN** for more information on controlling HELIOS® remotely with sACN.

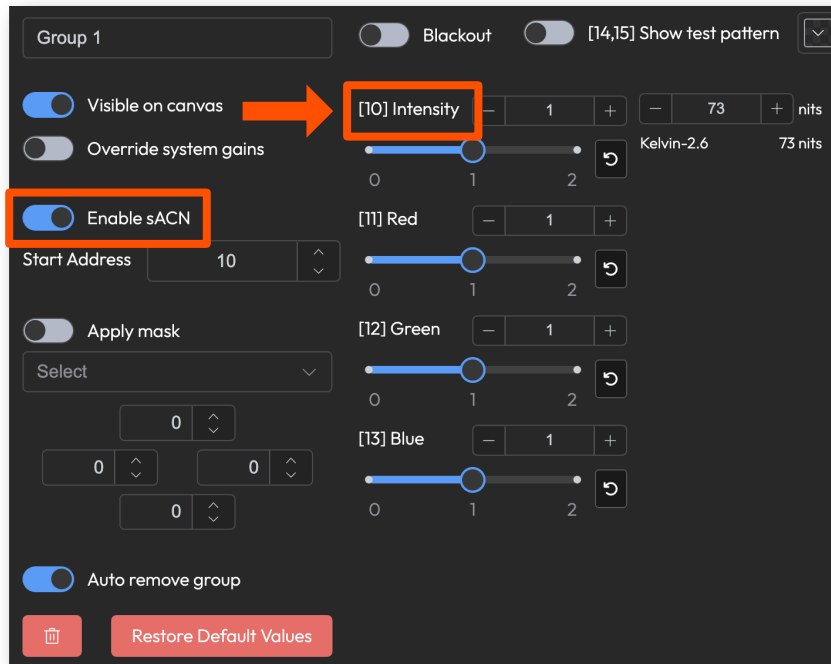



Figure 46: sACN enabled tile group controls

Apply mask toggle — Still images loaded using the **Settings > Still Store** pane are available in the dropdown. Select an image for HELIOS® to use as an outer edge mask for the display. This feature is useful for displays that have rounded physical bezels obscuring the display. Masking the pixels with HELIOS® prevents color aberrations that can occur when LEDs are partly obscured by scenery. The four adjustment coordinates shift the mask image up, down, left and right respectively. Each field can accept a value as high as +1000 or as low as -1000. However, the amount the mask moves is dependent on the mask pixel size. Smaller masks move less as there are less pixels available for adjustment. See the [Mask Appendix H](#) for more details.

Auto remove group — By default, when all of the tiles in a group have been ungrouped (removed) the group will also be removed. For cases where it is important to retain a group configuration, turn off the **Auto remove group** to avoid HELIOS® removing this group if it becomes empty, and keep its relevant settings. This way, tiles can be added and removed from groups without fear of losing the group settings.

Gains — **Intensity, Red, Green, and Blue** are gains controls for the group. The brightness (nits) is proportional to the overall system brightness (system brightness = intensity × RGB). Use the **Override system gains** toggle to have tiles operate independently.

Remove group  — An icon button to delete the current group.

Restore Default Values — A button to set tile group controls to default values.

5.4.7 Baseline

The baseline feature monitors systems by way of the connected topology. Press the **Set** button to have HELIOS® begin monitoring a system for changes.

Baseline monitors the following:

- **Switches** — switch type/model
- **Tiles** — mapped position, rotation, and tile type

Baseline can only include devices which have a complete topology. Meaning, when setting a baseline, if HELIOS® has not found a switch yet, HELIOS® certainly will not be aware of the tiles that are connected to it.

Once a baseline is set and HELIOS® is restarted, HELIOS® will ignore offline devices for the first sixty (60) seconds. This gives time for tiles to be discovered. After the sixty (60) seconds has elapsed, HELIOS® will raise offline alerts for any missing devices.

Baseline is set per HELIOS®. Each HELIOS® has its own baseline. The [Stacking](#) feature does not track baselines. Baseline does not monitor the display position and size.

Use the **Enabled** toggle to disable the baseline without having to clear the baseline. Sometimes a technician needs to reconfigure the display hardware without triggering a stack of baseline alerts.

When planning to use baseline, the Megapixel recommendation is to get the display system into a stable state, confirm video, and then take a baseline.

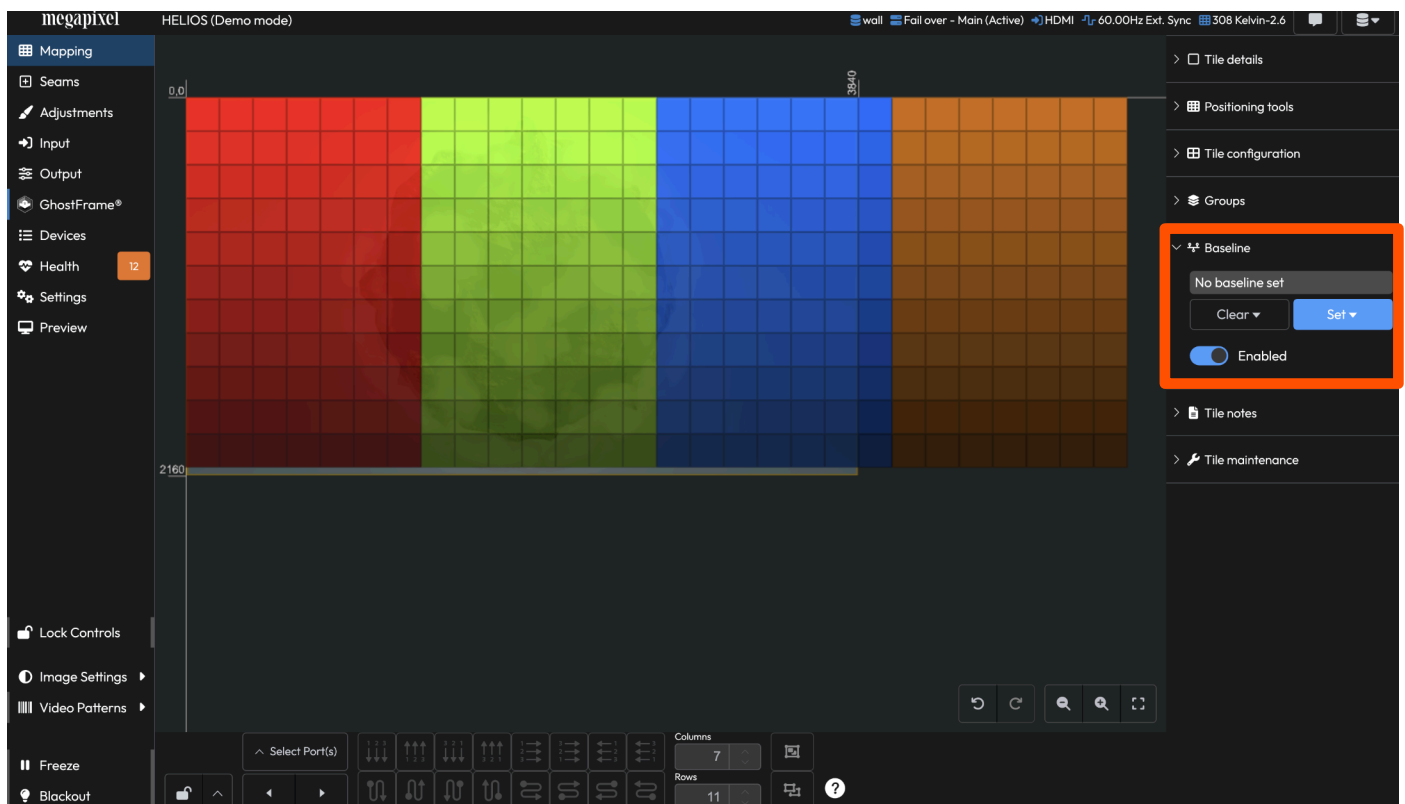

Figure 47: Baseline

5.4.7 Baseline

Baseline introduces three (3) new alert states:

Alert name	Alert Type	Description
Device offline	Orange Error	The device exists in the baseline, but is not connected to the system.
Baseline deviation	Yellow Warning	The Device topology matches, but it does not match the baseline state (e.g., the device has been moved).
Device unexpected	Yellow Warning	The device is connected, but not in the current baseline.

An alert count for each type is shown in the **Mapping pane > Baseline** menu.

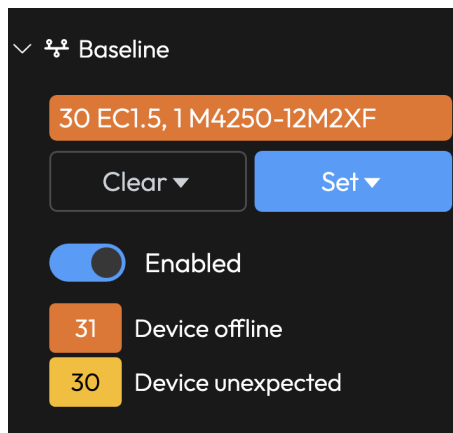

Figure 48: Baseline errors

Details about the alerts are available on the **Health** pane.

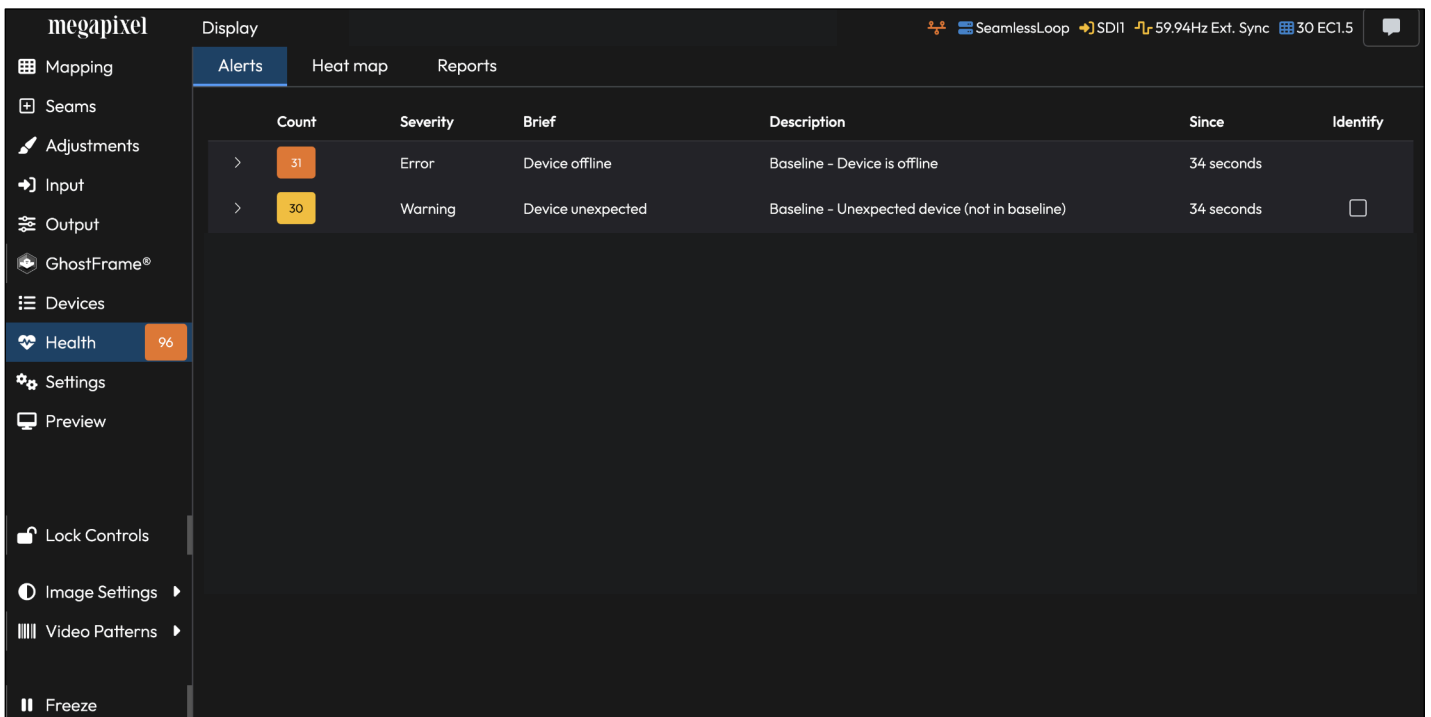



Figure 49: Health pane Baseline errors

5.4.8 Tile Notes

Tiles can be individually notated by selecting the tile on the **Mapping** pane. Then press the note icon button  under the **Tile notes** accordion or by the mapping pop-up menu.

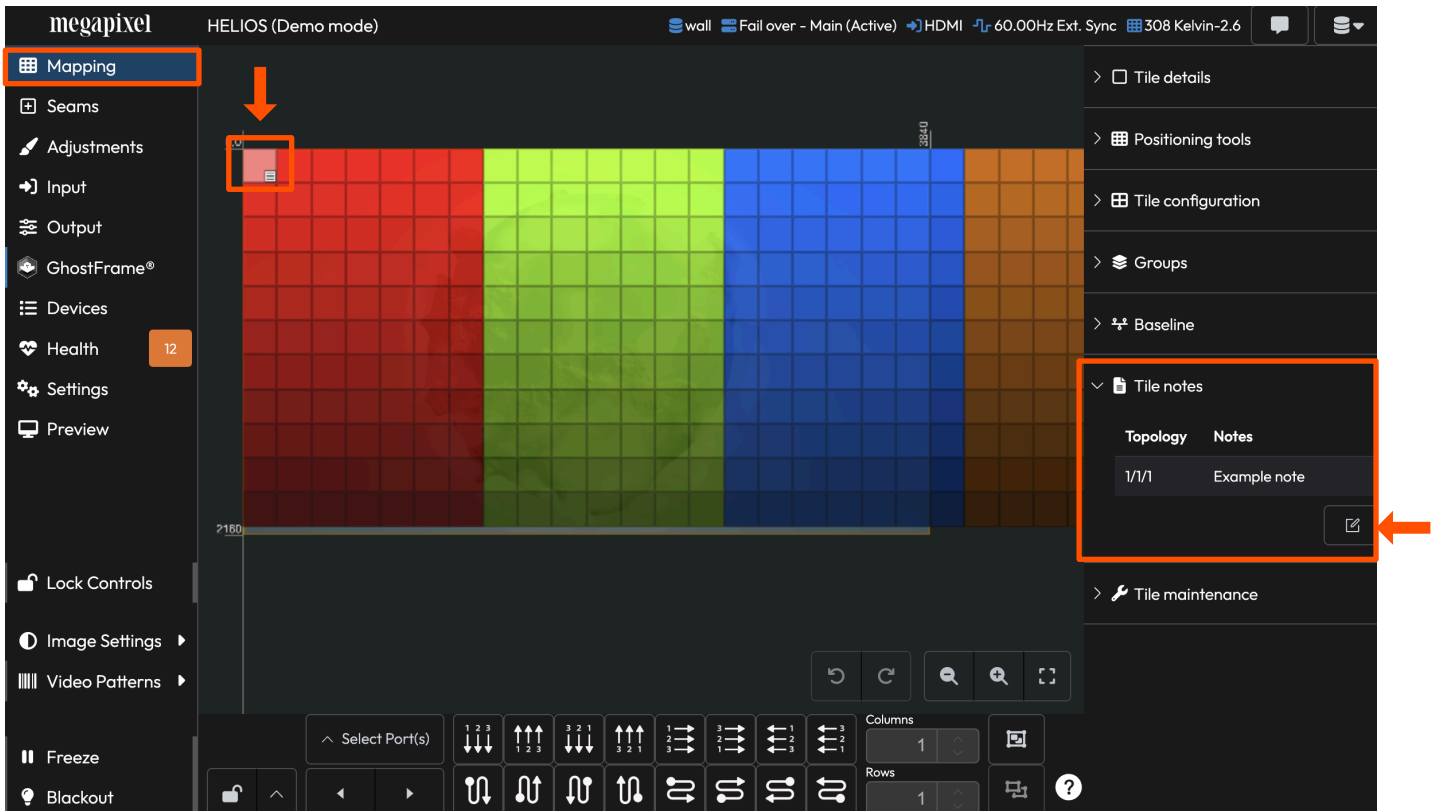

Figure 50: Tile notes

A note entry form pops over the main window. Add the desired note to the Notes field and tint the note a color if desired. Coloring notes can help categorize notes.

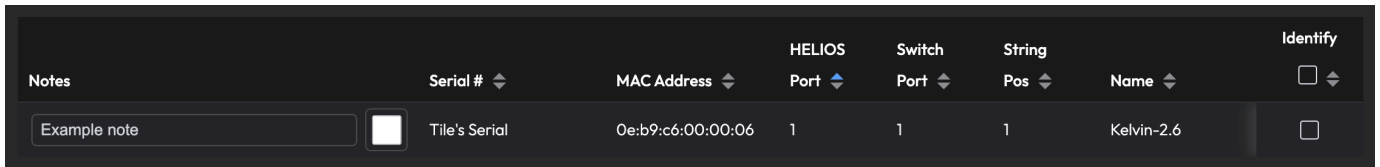

Figure 51: Note entry form

Once a note has been made, an icon will appear on the notated tile. Delete the text of the note to remove the note.



Figure 52: Note icon on tile

5.4.9 Tile Maintenance

This accordion contains commands that HELIOS® can send to tiles; **Reboot tile(s)**, **Eject**, **Mark Log of selected devices**, and **Download tile support log**. Some tiles support power control of the LDMs. When a system contains one or more tiles that support LDM power control, a **Power LDMs** toggle will appear above the stack of buttons (not pictured).

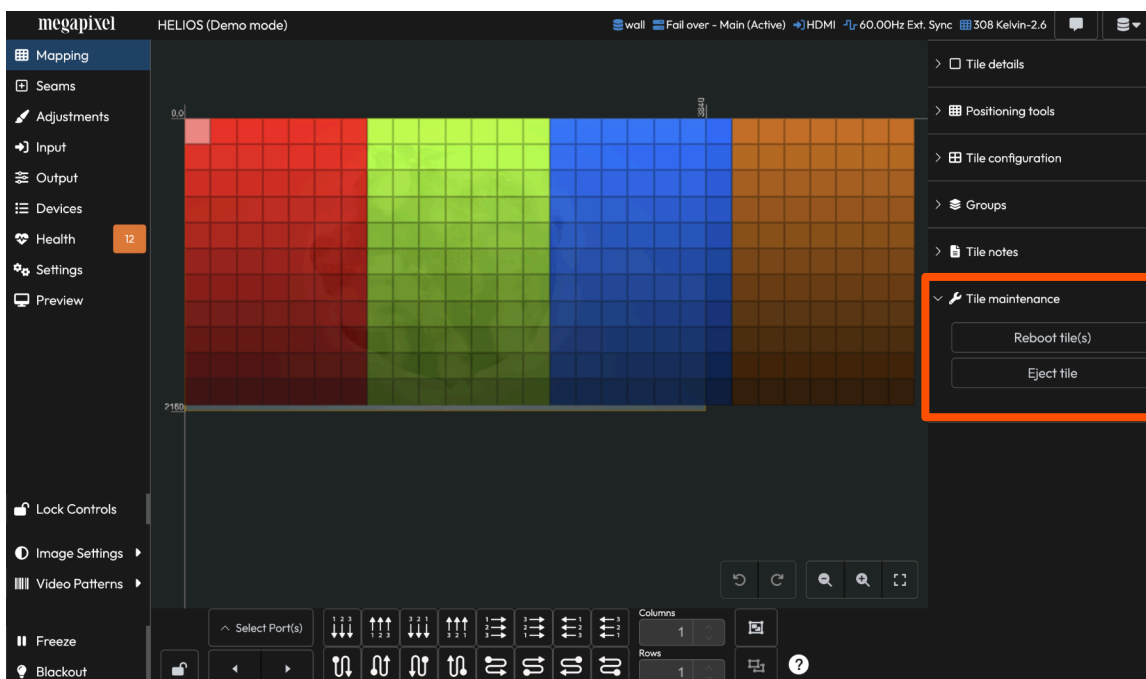

Figure 53: Tile maintenance

Reboot tile(s) — HELIOS® can send soft reboot commands to selected tiles. Select tiles to reboot and press the Reboot tile(s) button. **Caution using this feature in a show environment!** The tile(s) will go black as they reboot.

Eject tile — Some tiles have an ejection mechanism. This button can be used to trigger it. Once ejected a tile will lose communication with HELIOS®. For safety reasons only one tile at a time can be ejected.

5.4.10 Tile Maintenance (Advanced)

Mark Log of selected devices — This feature is used when working with the Megapixel support team. HELIOS® adds a line to the log and the selected tiles with a timestamp. When troubleshooting, it can be useful to mark the logs before doing X, and then mark again when Y is seen. To mark the logs, select tiles on the **Mapping** pane and press the button.

Download tile support log — Requests technical support logs from selected tile(s). These logs contain current state and some activity logs since boot that are used by Megapixel technicians and developers for troubleshooting. When tiles report information in this manner they may show visual artifacts for a few seconds as the tile is processing and sending the log. Steps to download the logs on the following page.

5.4.10 Tile Maintenance (Advanced) - Continued

Downloading logs:

1. Press the **Download tile support log** button.

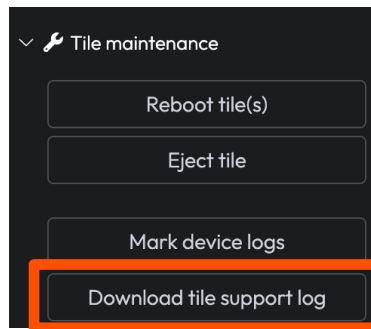

2. A warning will appear. Press OK to continue with the download.

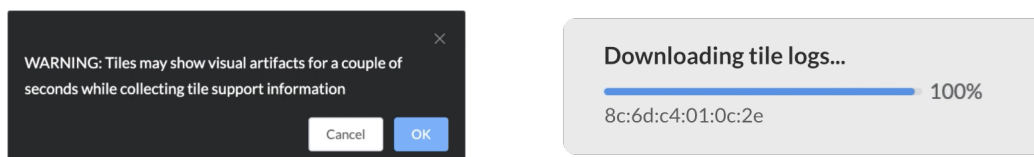

3. After pressing OK a zipped log file is downloaded to the download location set in the browser.

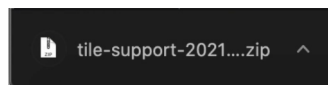

5.5 Input Pane

The HELIOS® supports four different types of input formats (HDMI, DisplayPort, SDI, and ST 2110). After a factory defaults restore, HELIOS® will automatically select the first valid input that it receives. As an example, if the first valid input HELIOS® receives is SDI, HELIOS® will remain selected on SDI even if the signal is no longer present. If SDI is unplugged and DisplayPort plugged in, the HELIOS® needs the user to select the DisplayPort source manually. Changes are sent live to the entire system immediately.

Inputs select dropdown — The HELIOS® interface for selecting inputs is a dropdown menu on the **Inputs** pane (highlighted by the orange rectangle below).

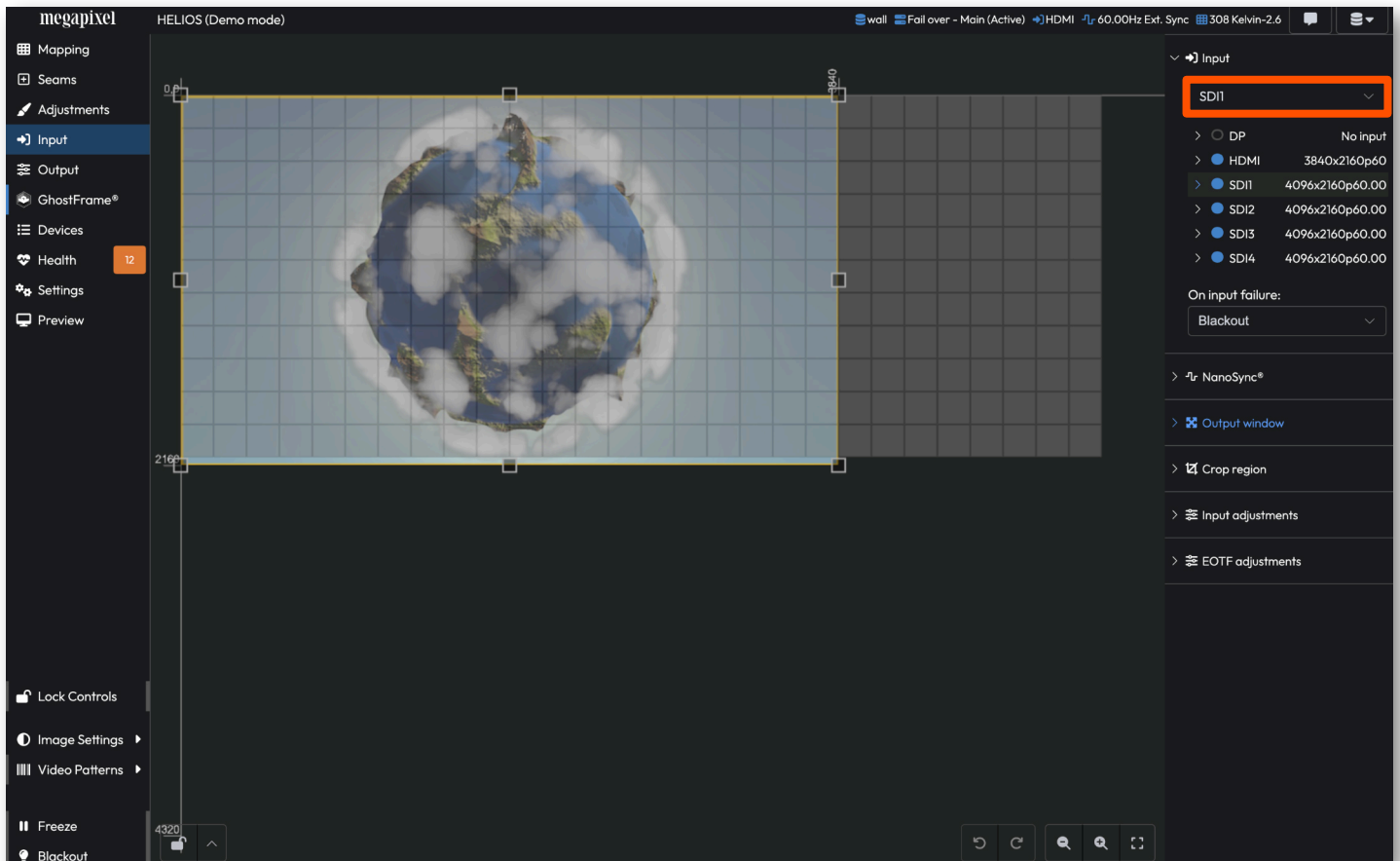

Figure 54: Input select

5.5.1 Input Details

Below the input select dropdown is the input details region. Each HELIOS® input format has a line with a disclosure triangle to view signal details. It is good practice to verify that the resolution and frequency HELIOS® has identified matches with the signal source.

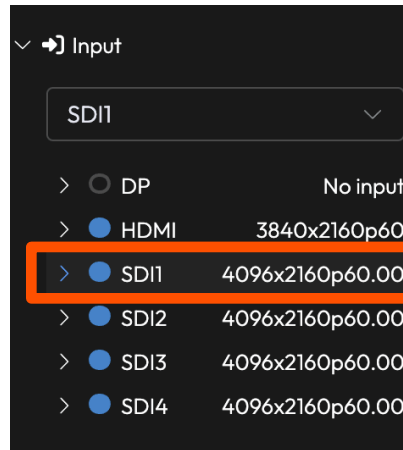

Figure 55: Input details

HELIOS® displays details for color timing, and sync. With advanced mode enabled in the HELIOS® settings, an information icon (arrow below) serves as a button to display advanced timing information.

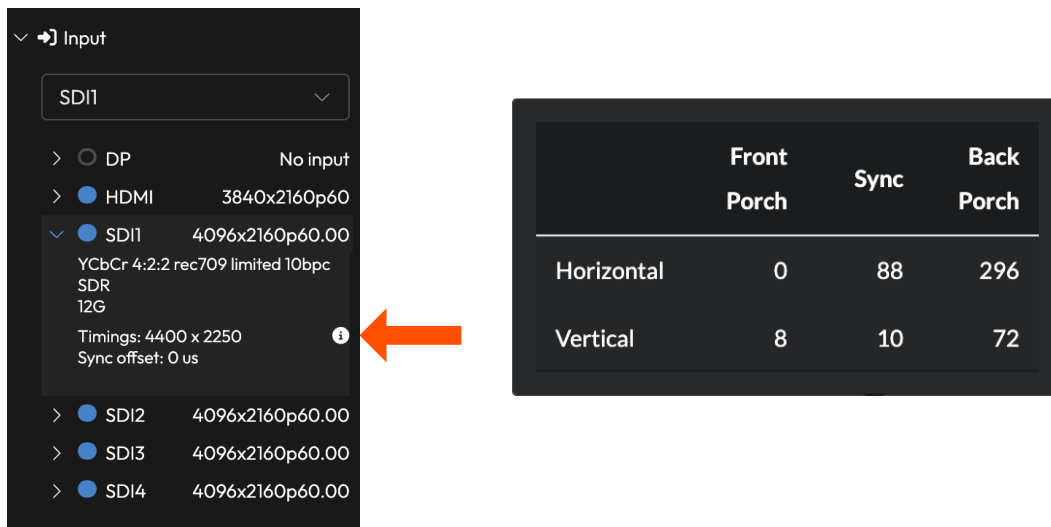
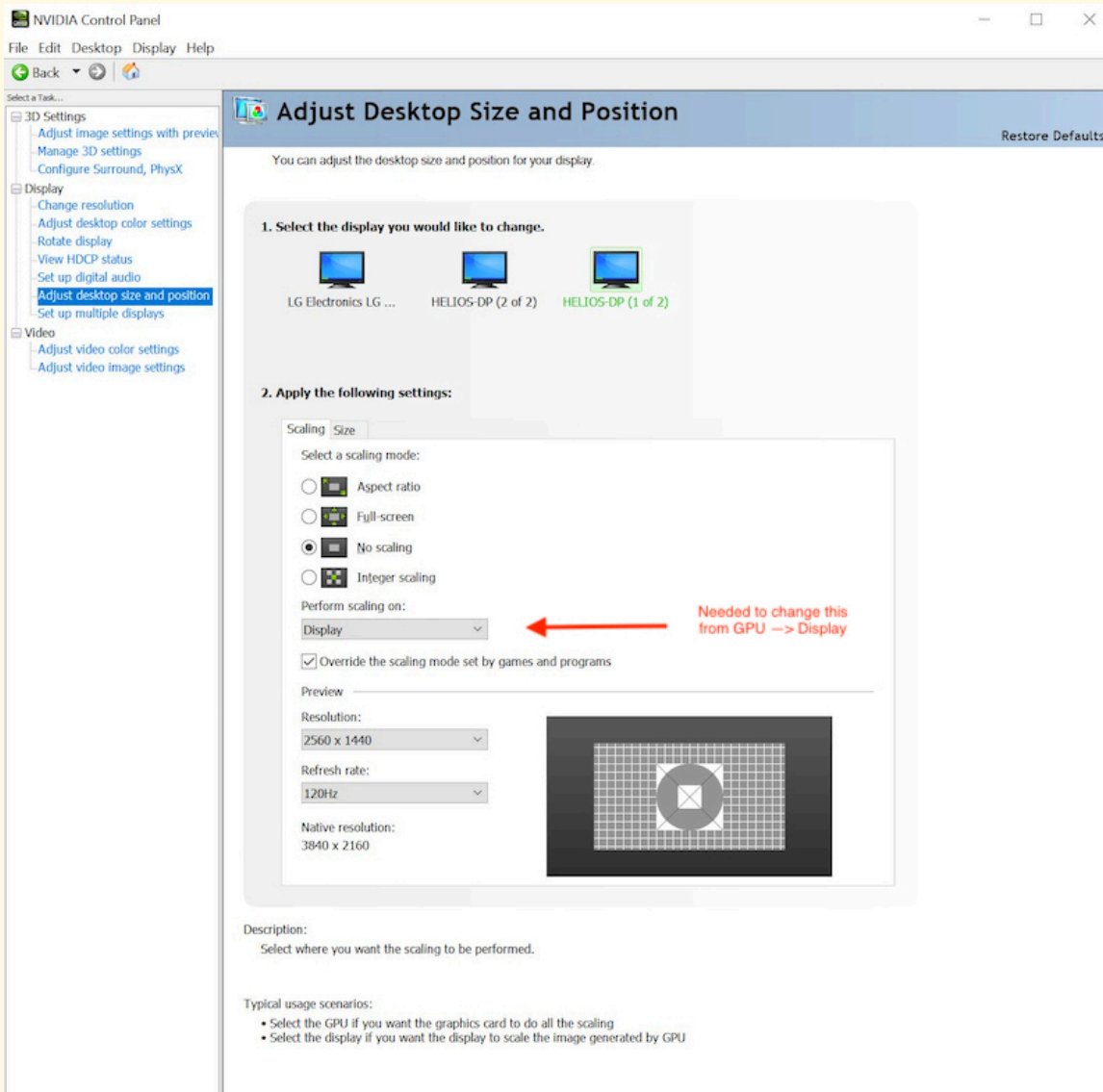

Figure 56: Advanced timing

5.5.1 Input Details

NOTE: When connecting a PC with an NVIDIA graphics card, the scaling settings can have an impact on how the video signal is identified to HELIOS®. Ensure that the scaling mode is set to **No scaling** and the dropdown, **Perform scaling on:** is set to **Display**.



5.5.1 Input Details

Sync — When an external sync (genlock) is not present, HELIOS® will lock to the frequency of the input signal. If using an external sync we strongly discourage using a different frequency than the selected input signal. Mismatched frequencies can cause stuttering and vertical tearing between displays, along with other undesirable artifacts. See Section [5.5.2 NanoSync®](#) for more information on selecting the Sync source.

Sync offset — Shows how far the input signal's timing is from the active sync signal. The spark line graph next to the value provides a quick visual summary of timing offset over time. The gray line shows the source sync; the colored line shows the measured sync difference for each input in milliseconds (ms).

What to look for:

- Stable value at or near zero — the input signal is locked to the sync signal
- Flat lines on the spark line — good timing alignment
- Shifting value or spikes — the source is not locked; possible drift, jitter, or timing anomaly
- Offset shifting more than half a frame time — something is adding significant delay to the signal

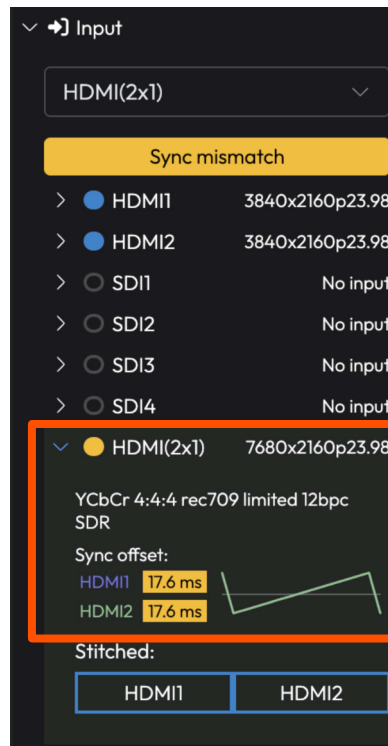

Figure 57: Sync offset

In the case of multiple inputs, the joined inputs will show the sync offset for each contributing input. Expand the stitched input details to see the sync offsets of the sources reported together. Often only one of the spark lines will be visible due to the fact that the lines are overlaid on top of each other. If the inputs are not in sync, a **Sync mismatch** warning will appear and the input status indicator will turn orange to warn about the sync issue.

5.5.1 Input Details



EDID (Advanced)

HELIOS® uses the EDID (Extended Display Identification Data) protocol to communicate the capabilities of its DisplayPort and HDMI input cards to connected media playback devices. Each input card has a default EDID preconfigured for the most common resolutions and frequencies.

A custom EDID may be needed when:

- A media player requires confirmation that HELIOS® supports a non-standard resolution or frame rate
- The system is returning to an unintended state after reboot or disconnect — a limited EDID with a single resolution and frequency can prevent this

With Advanced Mode enabled, three EDID functions are available via the icon buttons:

-  Upload custom EDID — load a custom binary EDID file
-  EDID Generator — create a custom EDID within HELIOS®
-  Reset to default — restore the card's built-in EDID

The status indicator shows Default when the built-in EDID is active and Custom when a custom file has been loaded. A custom EDID info box displays the specific EDID details when in custom mode.

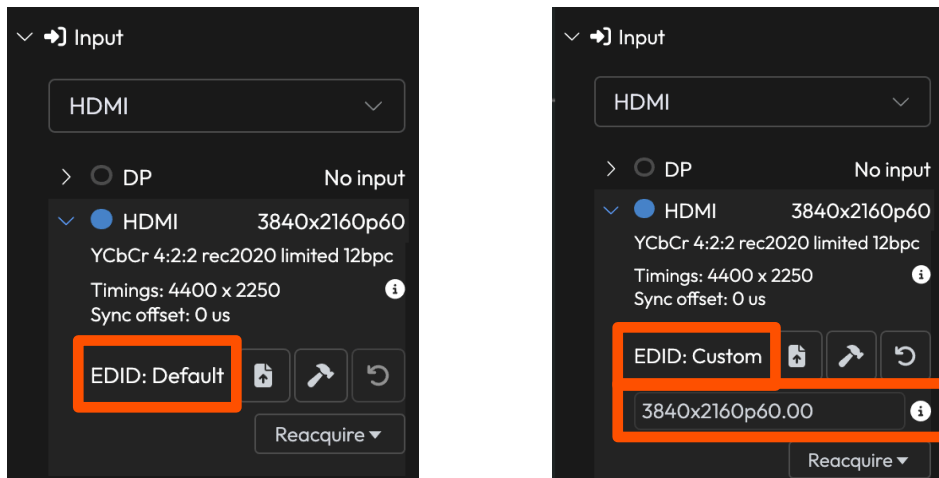
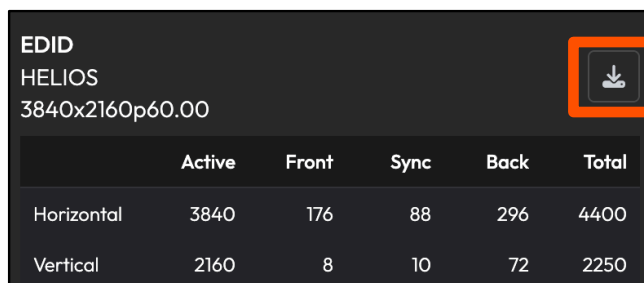

Figure 58: Upload EDID and Reset to default icon buttons

5.5.1 Input Details

Download an uploaded/generated EDID by clicking on the custom EDID info icon, then click on the download button in the window that opens.



EDID
HELIOS
3840x2160p60.00

	Active	Front	Sync	Back	Total
Horizontal	3840	176	88	296	4400
Vertical	2160	8	10	72	2250

Figure 59: EDID download button

When the **Create EDID** file icon button (hammer) is pressed, an **EDID Generator** window will open. Configure as needed. When finished configuring, either **Generate & Apply** to have the input port re-configured or **Generate and Download** to save the file.

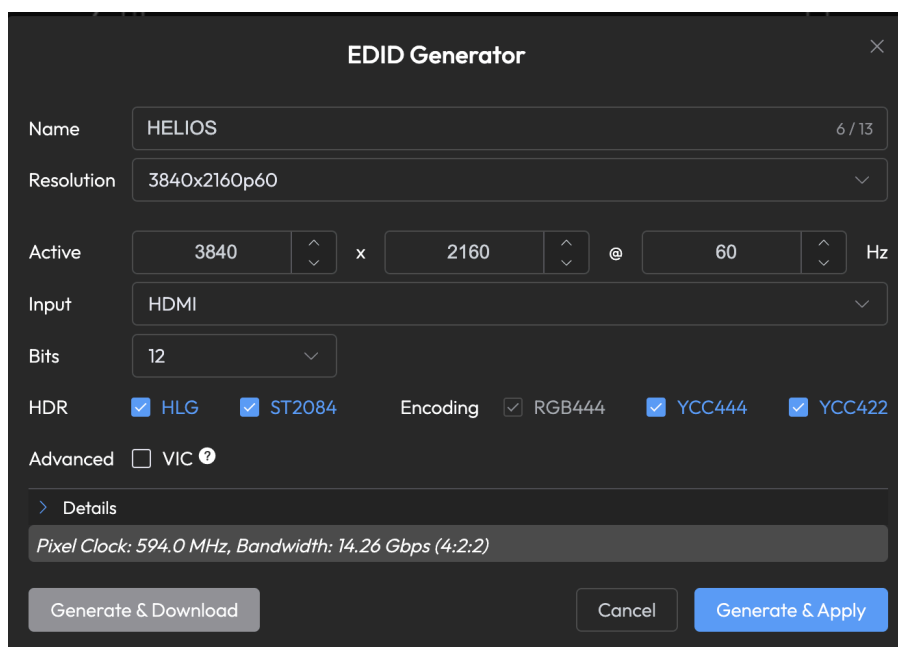

EDID Generator

Name: HELIOS 6 / 13

Resolution: 3840x2160p60

Active: 3840 x 2160 @ 60 Hz

Input: HDMI

Bits: 12

HDR: HLG ST2084 Encoding: RGB444 YCC444 YCC422

Advanced: VIC ?

> Details
Pixel Clock: 594.0 MHz, Bandwidth: 14.26 Gbps (4:2:2)

Buttons: Generate & Download, Cancel, Generate & Apply

Figure 60: EDID Generator window

NOTES:

- RGB cannot be disabled, as EDIDs have RGB as a minimum.
- Timing is calculated using the RBv2 algorithm (Reduced Blanking version 2).
- Use the VIC check box to include the appropriate VIC (Video Identification Code). This is required by some sources. Using this feature can result in fractional frequencies. Fractional frequencies refer to video refresh rates or frame rates that are not whole integers, but instead fractions—most notably 29.97 Hz and 59.94 Hz.

5.5.1 Input Details

With [Advanced Mode](#) enabled, the DisplayPort and HDMI ports on HELIOS® have a **Reacquire** button. Sometimes problematic inputs need to be reacquired. This can be done by physically unplugging the input and replugging it or by using the **Reacquire** button which remotely resets/re-syncs the input. This button can help avoid having to physically visit a HELIOS® to re-plug the problematic input.

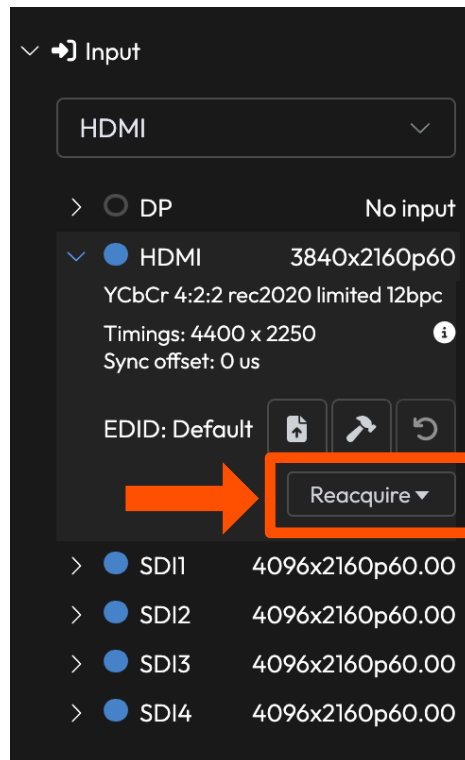

Figure 61: HDMI Reacquire

5.5.1 Input Details

HDCP — HELIOS® supports HDCP 2.x signals (2.2 or later; see the HDCP entry in [Appendix L](#) for details). HELIOS® requires a separate HDCP license to receive an HDCP signal. Please contact your Megapixel sales representative for this license. Once licensed, HELIOS® will automatically negotiate an HDCP connection when possible. On a successful handshake the input details will report which version is being received (example below).

Prerequisites:

- HELIOS® v22.04.0 software
- HDMI 2.0 (rev 2) VFMC card. (Megapixel part number: PCB-0215)
- HELIOS® HDCP license

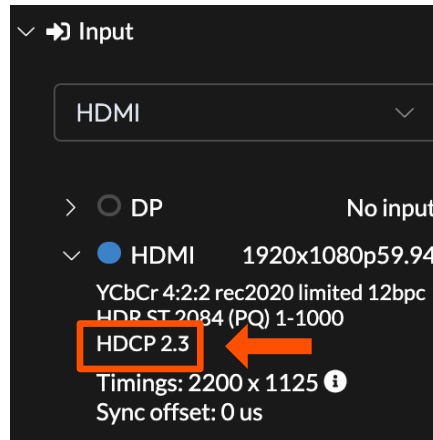

Figure 62: HDCP details on the HDMI input

NOTE: When troubleshooting HDCP protected input signals, ensure the upstream device generating the signal is set to negotiate HDCP 2.x. HDCP 1.4 protected signals can appear to be valid on the input details report, but display as black, blue or other aberrant color.

120Hz — HELIOS® supports 120Hz input signals (see the [Input Capability Matrix](#) in Appendix K). Using a 120Hz input source will reduce the maximum quantity of pixels by half (e.g., at 30Hz/12-bit, a 10Gb HELIOS® fiber port supports up to 8,075,000 pixels — 120Hz operation halves this to approximately 4,019,000 pixels). 720p and 1080p are the best suited input resolutions for 120Hz operation.

5.5.1 Input Details

Stitched SDI — HELIOS® supports input stitching. This feature will join from two (2) to four (4) rasters depending on the option selected. The inputs with a formula in the line (e.g., **SDI (1x2) 4096x4320p60**) are stitched inputs. **(1x2)** indicates one (1) raster wide and two (2) rasters tall. In this case, HELIOS® is stitching two vertical (top to bottom) rasters. In the example image below **SDI (1x2)** is selected. HELIOS® displays the input details and also illustrates which SDI ports are going to be stitched. In this case it is SDI ports 1 and 3. If selected on an input with a **(2x1)** designator, the picture is made up of two (2) side by side rasters. See the stitched input configuration tables in [Section 5.5.1](#) for the SDI/ST 2110 input number to raster position details of each stitched input option.

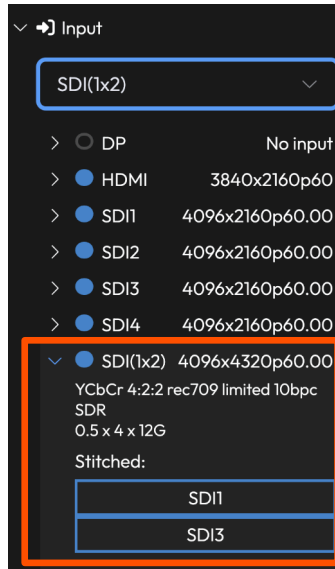

Figure 63: Stitched SDI

Stitched Dual HDMI / Dual DisplayPort — When HELIOS® has dual HDMI 2.0b or dual DisplayPort cards installed, the two rasters are stitched together automatically. The input dropdown menu will show the stitched rasters as two options **(1x2)** one wide by two tall or **(2x1)** two wide by one tall.

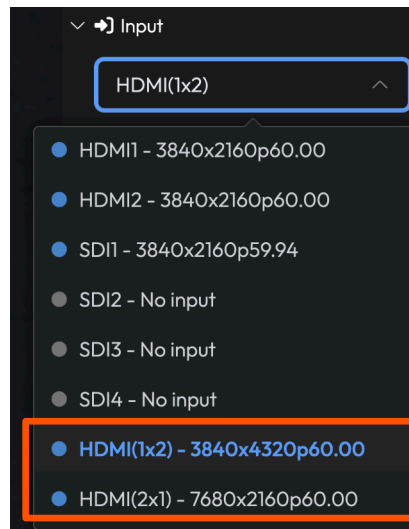

Figure 64: Dual DisplayPort options

NOTE: Stitched HDMI and DisplayPort inputs cannot be scaled. When stitching is enabled, the output window is locked to the stitched input size. Inputs combined with square division also cannot be scaled.

5.5.1 Input Details

ST 2110 — HELIOS® supports ST 2110 digital media over IP. See [Appendix G](#) for more details about ST 2110 systems. Megapixel branded blue or purple label SFPs are installed in the four input SFP cages of the HELIOS® instead of the default SDI SFPs. If the 100GB input module is used, any 100G QSFP28 SFP can be used. The HELIOS® operating mode **Processor Settings > Operating mode** needs to be set to **ST 2110** mode.

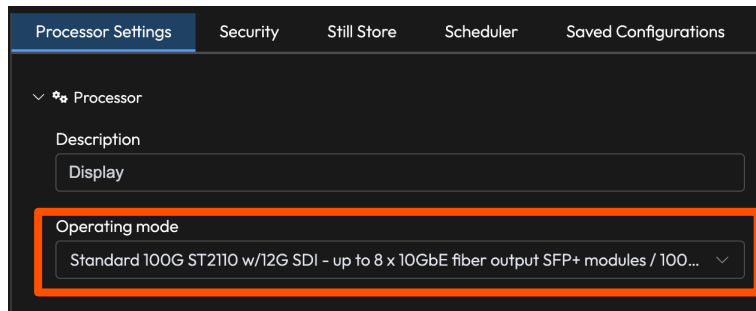

Figure 65: ST 2110 Operating mode

HELIOS® needs an SDP (Session Description Protocol) record to locate an ST 2110 stream on a network. SDP records are small text files that describe the streaming media's parameters to HELIOS®. SDP records are essential for locating and configuring an ST 2110 video signal. Use the upload icon button (see figure below) to send an SDP record to HELIOS®. See Appendix G for an [example SDP record](#).

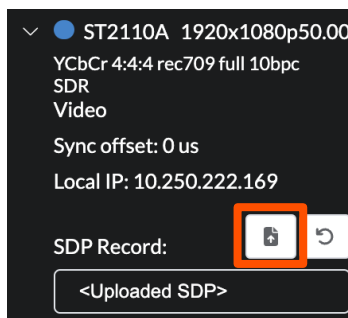

Figure 66: Loading a SDP Record

In ST 2110 operating mode, HELIOS® disables SDI . The input pane will show the available ST 2110 inputs. ST 2110 inputs are stitching capable. Select a single input (e.g., **ST2110A**) to connect a single stream or select a stitched input to show more than one input at the same time. In the example below, **ST 2110(2x2)** indicates that all four (4) ST 2110 inputs are being stitched. The following page has more details on the stitching options.

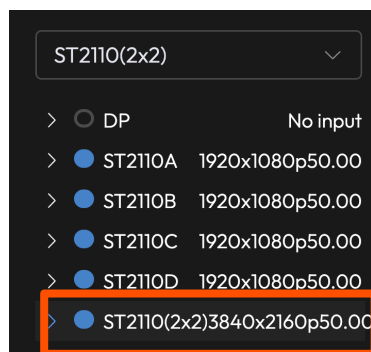

Figure 67: ST 2110 stitched input

5.5.1 Input Details

The tables below show the various possible stitched input settings and how HELIOS® will configure the inputs.

Stitched DisplayPort and HDMI 2.0b

Stitched Input	Active Ports	Configuration			
DP(1x2) - 3840x4320p60	2x VFMC DisplayPort	Stitched vertically as a tall raster	<table border="1"><tr><td>1</td></tr><tr><td>2</td></tr></table>	1	2
1					
2					
DP(2x1) - 7680x2160p60	2x VFMC DisplayPort	Stitched horizontally as a wide raster	<table border="1"><tr><td>1</td><td>2</td></tr></table>	1	2
1	2				
HDMI(1x2) - 3840x4320p60	2x VFMC HDMI	Stitched vertically as a tall raster	<table border="1"><tr><td>1</td></tr><tr><td>2</td></tr></table>	1	2
1					
2					
HDMI (2x1) - 7680x2160p60	2x VFMC HDMI	Stitched horizontally as a wide raster	<table border="1"><tr><td>1</td><td>2</td></tr></table>	1	2
1	2				

Stitched SDI

Stitched Input	Active Ports	Configuration					
SDI(1x2) - 4096x4320p60	SDI Inputs 1 and 3	Stitched vertically as a tall raster	<table border="1"><tr><td>1</td></tr><tr><td>3</td></tr></table>	1	3		
1							
3							
SDI(1x3) - 4096x6480p60	SDI Inputs 1, 3, and 2	Stitched vertically as a tall raster	<table border="1"><tr><td>1</td></tr><tr><td>3</td></tr><tr><td>2</td></tr></table>	1	3	2	
1							
3							
2							
SDI(1x4) - 4096x8640p60	SDI Inputs 1, 3, 2, 4	Stitched vertically as a tall raster	<table border="1"><tr><td>1</td></tr><tr><td>3</td></tr><tr><td>2</td></tr><tr><td>4</td></tr></table>	1	3	2	4
1							
3							
2							
4							
SDI(2x1) - 8192x2160p60	SDI Inputs 1 and 3	Stitched horizontally as a wide raster	<table border="1"><tr><td>1</td><td>3</td></tr></table>	1	3		
1	3						
SDI(2x2) - 8192x4320p60	SDI Inputs 1, 3, 2, 4	Stitched as a square raster	<table border="1"><tr><td>1</td><td>3</td></tr><tr><td>2</td><td>4</td></tr></table>	1	3	2	4
1	3						
2	4						
SDI(3x1) - 12288x2160p60	SDI Inputs 1, 3, and 2	Stitched horizontally as a wide raster	<table border="1"><tr><td>1</td><td>3</td><td>2</td></tr></table>	1	3	2	
1	3	2					
SDI(4x1) - 16384x2160p60	SDI Inputs 1, 3, 2, 4	Stitched horizontally as a wide raster	<table border="1"><tr><td>1</td><td>3</td><td>2</td><td>4</td></tr></table>	1	3	2	4
1	3	2	4				

Stitched ST 2110

Stitched Input	Active Ports	Configuration					
ST2110(1x2) - 4096x4320p60	ST 2110 Inputs 1 and 3	Stitched vertically as a tall raster	<table border="1"><tr><td>1</td></tr><tr><td>3</td></tr></table>	1	3		
1							
3							
ST2110(1x3) - 4096x6480p60	ST 2110 Inputs 1, 3, and 2	Stitched vertically as a tall raster	<table border="1"><tr><td>1</td></tr><tr><td>3</td></tr><tr><td>2</td></tr></table>	1	3	2	
1							
3							
2							
ST2110(1x4) - 4096x8640p60	ST 2110 Inputs 1, 3, 2, 4	Stitched vertically as a tall raster	<table border="1"><tr><td>1</td></tr><tr><td>3</td></tr><tr><td>2</td></tr><tr><td>4</td></tr></table>	1	3	2	4
1							
3							
2							
4							
ST2110(2x1) - 8192x2160p60	ST 2110 Inputs 1 and 3	Stitched horizontally as a wide raster	<table border="1"><tr><td>1</td><td>3</td></tr></table>	1	3		
1	3						
ST2110(2x2) - 8192x4320p60	ST 2110 Inputs 1, 3, 2, 4	Stitched as a square raster	<table border="1"><tr><td>1</td><td>3</td></tr><tr><td>2</td><td>4</td></tr></table>	1	3	2	4
1	3						
2	4						
ST2110(3x1) - 12288x2160p60	ST 2110 Inputs 1, 3, and 2	Stitched horizontally as a wide raster	<table border="1"><tr><td>1</td><td>3</td><td>2</td></tr></table>	1	3	2	
1	3	2					
ST2110(4x1) - 16384x2160p60	ST 2110 Inputs 1, 3, 2, 4	Stitched horizontally as a wide raster	<table border="1"><tr><td>1</td><td>3</td><td>2</td><td>4</td></tr></table>	1	3	2	4
1	3	2	4				

5.5.1 Input Details

When stitching together multiple video sources in HELIOS®, it is really important that all the inputs are in sync. If they are not, the video frames can show up at different times. This causes visible seams, tearing, or the picture not lining up properly where the sources meet. Keeping sources synchronized means each part of the display updates at the same time. HELIOS® will indicate that stitched sources are not in sync with an orange dot next to the stitched input select dropdown when selecting a stitched input and also in the list of available stitched inputs below the dropdown menu.

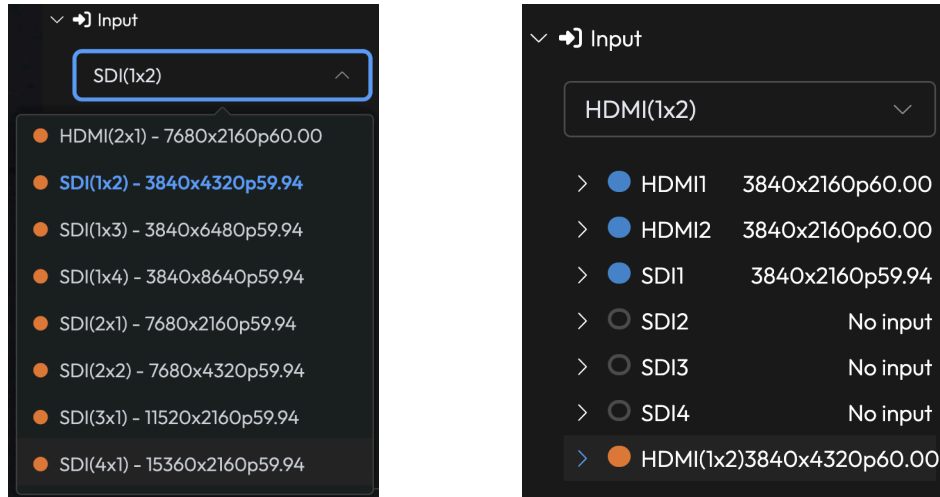

Figure 68: Stitched input sync warning

To better understand the sync issue, expand the details on each source (the input source details not one of the stitched inputs) with the disclosure triangle and look at the **Sync offset** values. See the previous section on [Sync](#) for more details.

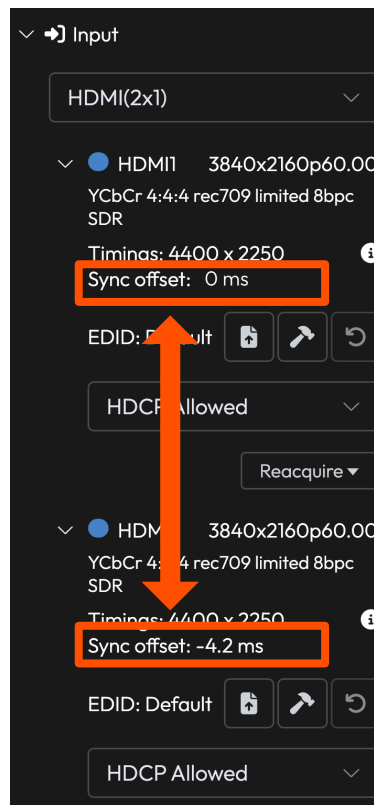

Figure 69: Sync offset

5.5.1 Input Details

On input failure — Select how the HELIOS® should behave if the selected input no longer has a valid signal.

Blackout — HELIOS® will display black.

Show still — HELIOS® will display a preselected still image. See the [Processor Settings > Still Store](#) section for loading images.

Switch to still — HELIOS® enables Show Still and begins displaying the selected still image. Use the **Show still** toggle to toggle the image off and return to displaying the input video.

Show input — HELIOS® will show the selected input. When the selected input recovers, HELIOS® will revert to it. As an example, SDI1 is selected on the Input pane. The On input failure > Show input is set to HDMI. If SDI1 fails, HELIOS® will display HDMI. When SDI1 recovers, HELIOS® automatically switches back to SDI1.

Switch to input — HELIOS® will switch to the selected input. As an example, SDI1 is selected on the Input pane. The On input failure > Switch to input is set to HDMI. If SDI1 fails, HELIOS® will switch the input to HDMI. When SDI1 recovers, HELIOS® does nothing. The input remains selected on HDMI.

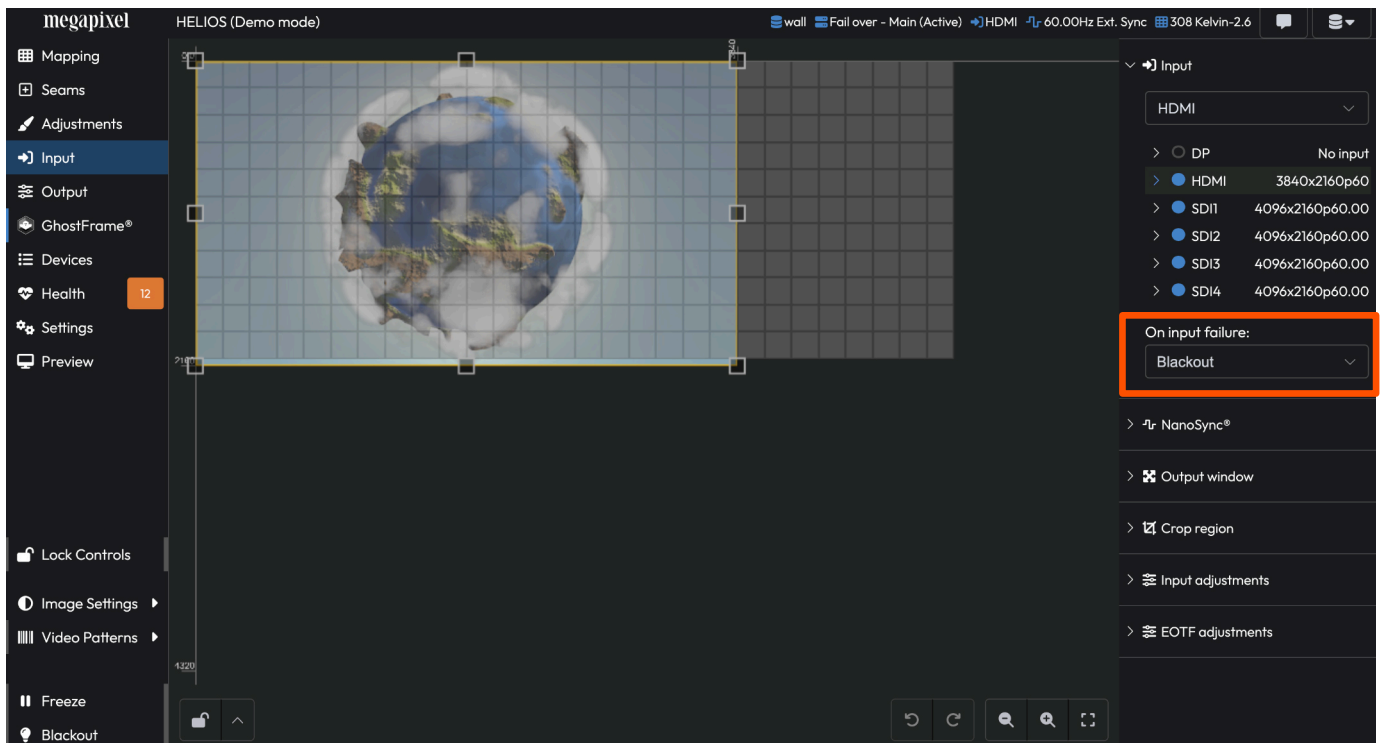

Figure 70: On input failure location

5.5.2 NanoSync®

HELIOS® can sync frames to either the frame rate of the inbound signal or to an external clock (analog genlock or PTP). Use the dropdown menu to select a sync source. Shown below is HELIOS® set to **External Genlock**. HELIOS® reports **Locked to: External Genlock** in the NanoSync® status at the top of the NanoSync® accordion. When an external clock signal is required (as is the case with redundant systems), use either genlock (rear BNC port marked as **Sync** on the HELIOS®) or use a PTP clock. To use a PTP clock, ensure the PTP device is on the HELIOS® **Management LAN** and select the **PTP** option from the dropdown menu. See [Appendix G](#) for more information.

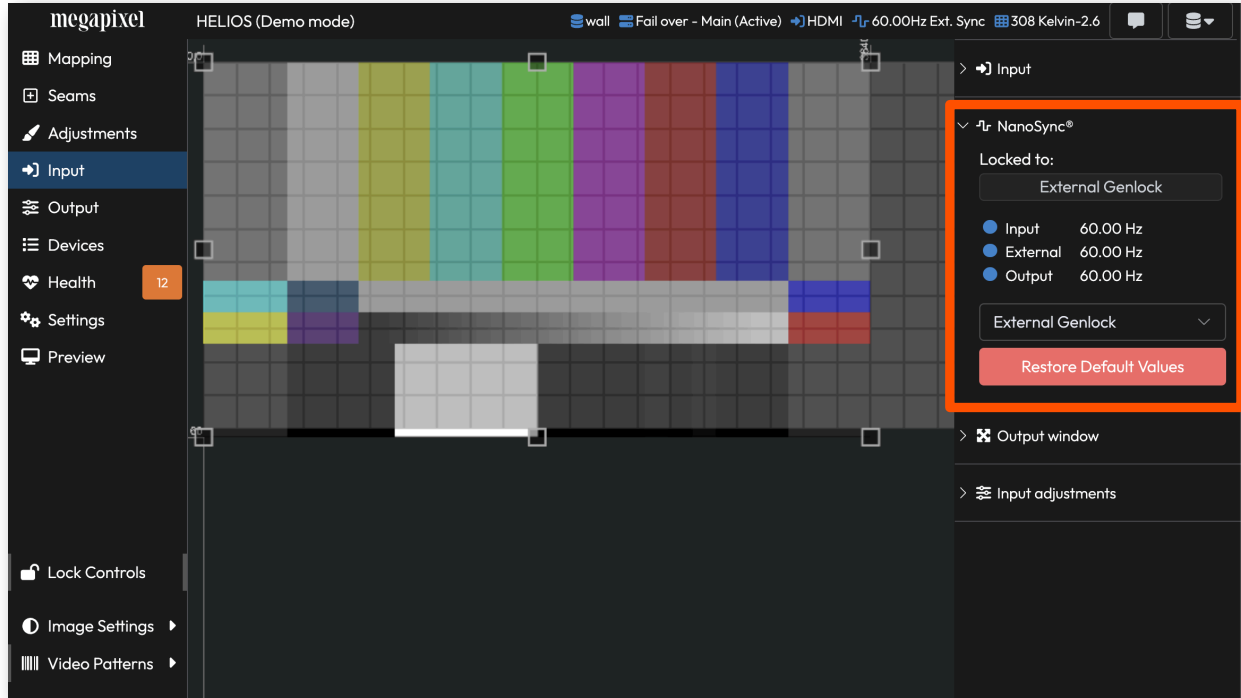

Figure 71: Sync settings

When sync is enabled, the front display of the HELIOS® will report the sync frame rate it is receiving. If the HELIOS® does not recognize an external sync signal, it will report **No Sync**.

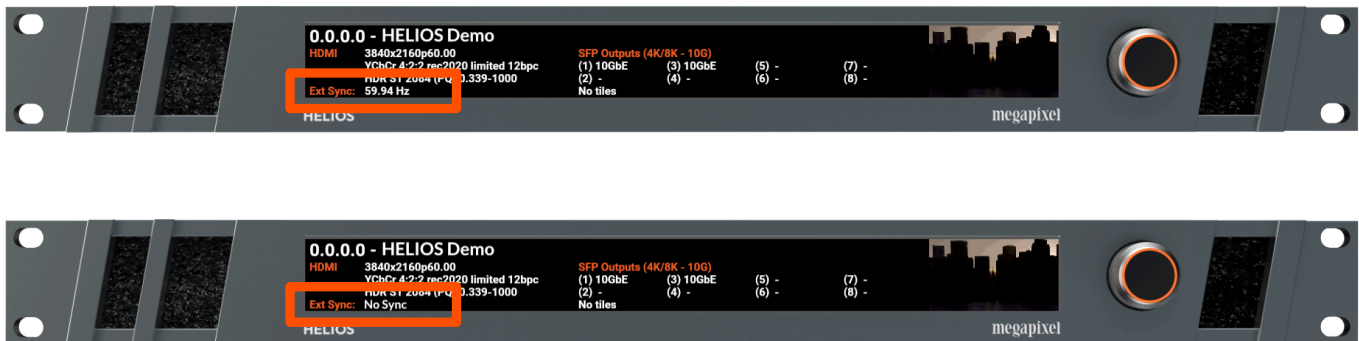

Figure 72: Front panel sync report

5.5.3 NanoSync® (Advanced)

HELIOS® has hidden NanoSync® controls when set to **Advanced Mode**. Enable Advanced Mode under **Settings > Processor Settings > Advanced**, to reveal the hidden controls, then return to the NanoSync® panel to use them. HELIOS® NanoSync® gives users the most accurate sync control of any LED system. HELIOS® synchronizes the actual light output of the LED tile to the source within 1/4 microsecond (250 nanoseconds). Often HELIOS® delivers frames much faster than other equipment such as projectors. Cameras can also require precise alignment to match with the shutter exposure.

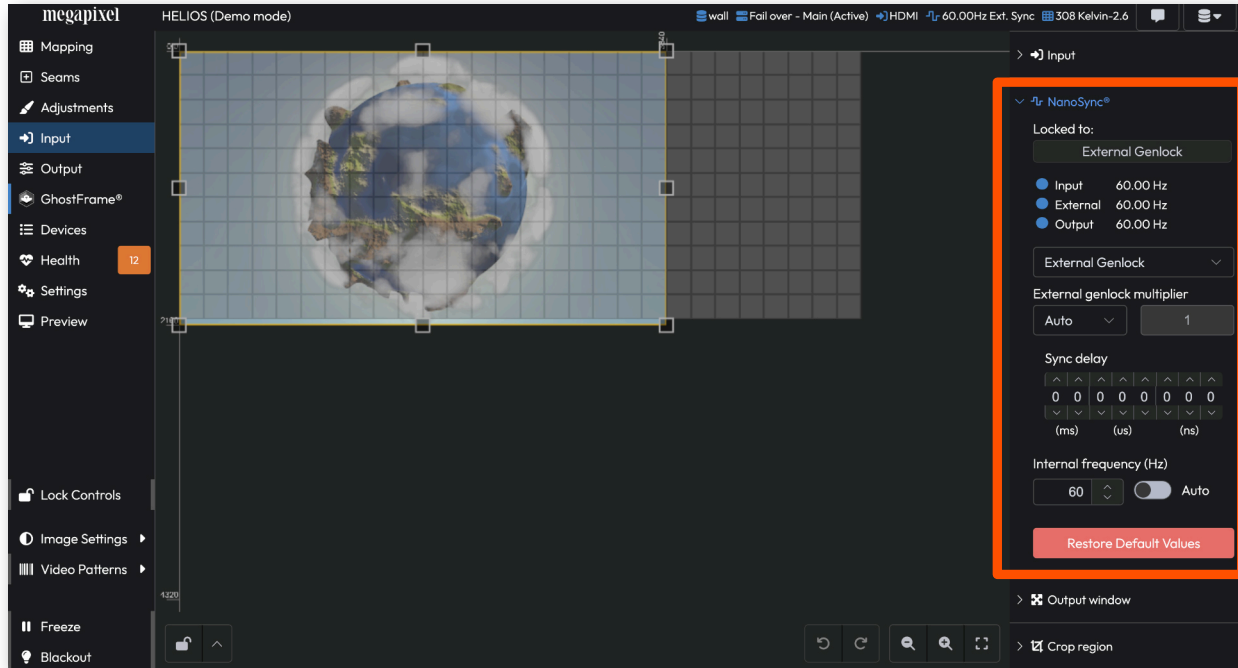

Figure 73: Advanced Sync settings

External genlock multiplier (Advanced)

When set to **External genlock** as the sync source, the **External genlock multiplier** becomes available to boost the effective genlock rate. This is useful in cases where either the external sync isn't able to run fast enough, or needs a frequency not supported by the sync generator. A common use case is where a 48Hz system is needed. The genlock source is set to 24Hz and multiplied (2x) to 48Hz to match the input video frequency. Other common cases are to boost 50Hz to 100Hz and 60Hz to 120Hz. The multiplier does not change the inbound video frame rate; it only affects how the system refresh rate is derived from the reference.

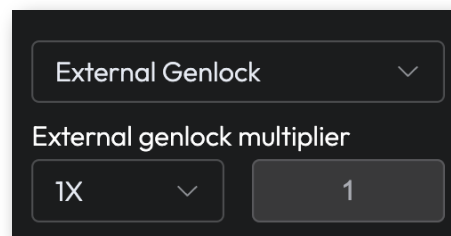

Figure 74: External genlock multiplier

5.5.3 NanoSync® (Advanced)

Internal frequency (Hz) (Advanced)

If the inbound signal is ever lost, HELIOS® will continue to output test patterns at the frame rate of the last valid input. In some cases, it is useful to disable **Auto** and set the output frequency manually. This allows test patterns to run at the expected frequency of a future input signal before it arrives.

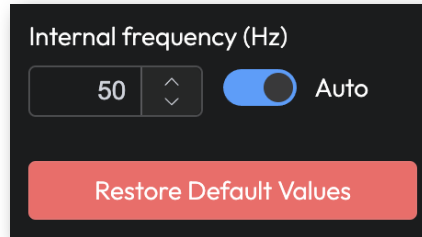

Figure 75: No Input signal frequency (Auto)

5.5.4 Output Window

The Output Window contains the HELIOS® video positioning and scaling controls. The active input's raster is mapped onto a resizable Output Window, shown as the color bar region in the example below. The gray grid behind it represents the active tiles of the LED display.

Fit buttons — quickly set the Output Window size to a preset:

- **Input** — sizes the window to match the active input raster
- **Display** — sizes the window to match the tile display area
- **4:3 / 16:9** — sets the window to the selected aspect ratio, preventing image distortion

Resize handles — small square handles at the edges of the Output Window. Drag any handle to resize manually, or enter precise values in the width and height numerical fields. Maximum width is 8,192 pixels; maximum height is 16,383 pixels.

Position — drag the Output Window to reposition it, or enter precise coordinates in the X and Y fields.

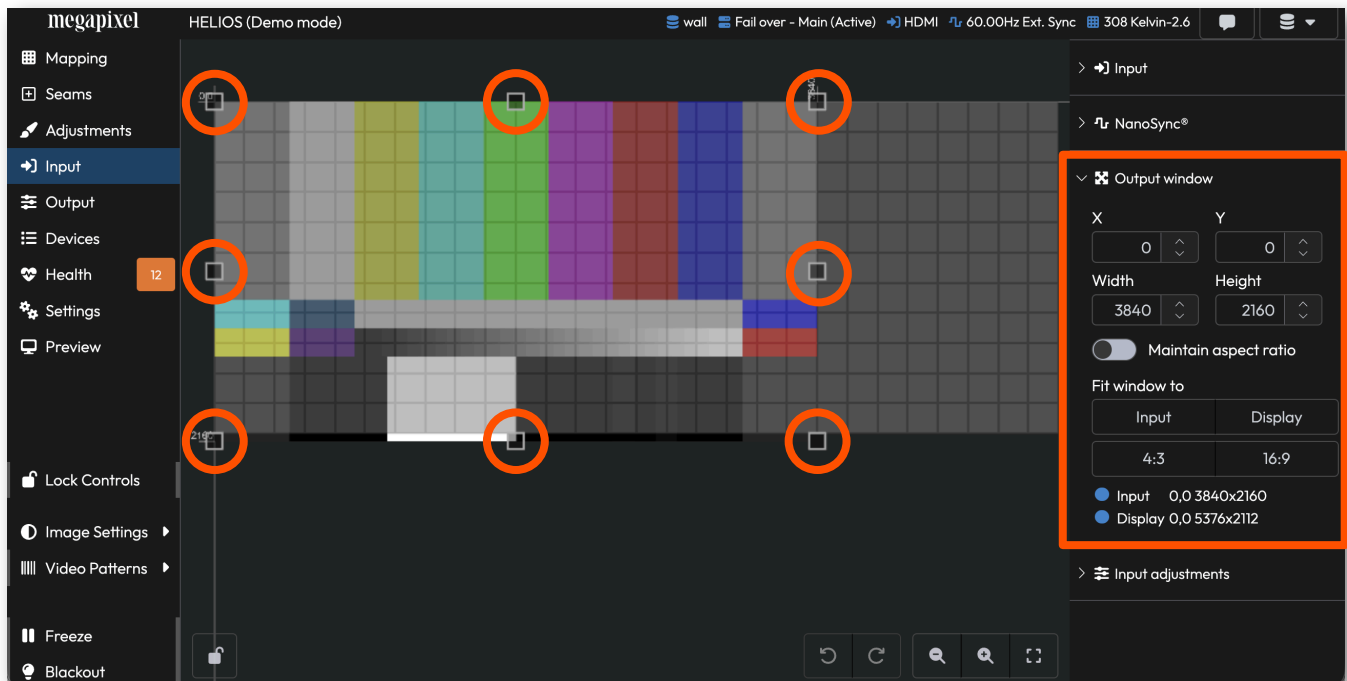

Figure 76: Output window

The HELIOS® accepts a wide range of values for the **Output window** size. The maximum width is 8,192 and the maximum height is 16,383. When dragging the resizing handles, the UI will stop at these values. Entering values outside this range in the width and height numerical fields will be ignored. The limits described above only apply when scaling. When not scaling (because of stitched inputs or scaler disabled) the limits are different and the output window exactly matches the input.

NOTE: Any up/down scaling or aspect ratios beyond 4:1 should be reviewed by the Megapixel team.

5.5.5 Output Window (Advanced)

With [Advanced Mode](#) enabled, HELIOS® offers more control over scaling. The **Output image scaler** toggle controls whether scaling is applied to the output. Below this toggle, a dropdown menu offers three scaling options: Lanczos, Bilinear, and Nearest Neighbor. The chosen method can significantly affect the quality and sharpness of content on the display. The following describes each method and when to use it.

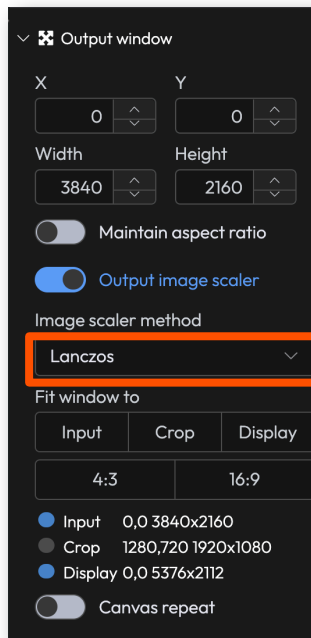

Figure 77: Image scaler method selection

Lanczos Scaling

- **How it works:** Uses a windowed sinc function to reconstruct pixels with high fidelity, preserving fine details and sharpness.
- **Result:** Crisp, sharp images with minimal aliasing; may produce faint halos near areas of strong contrast.
- **Best for:** Logos, high-resolution graphics, fine art, and other content where detail retention is critical.
- **When to use:** Appropriate for detailed brand visuals, high-resolution digital signage, or broadcast applications that require maximum sharpness. Start with this one if unsure which method to use.

TIP: The Lanczos approach to scaling preserves fine image details and sharp edges exceptionally well, making visuals appear crisp and natural. This is especially important for intricate graphics, corporate logos, and high-resolution photographic content common on premium LED walls. The result is superior clarity in both upscaling and downscaling, with smooth transitions and minimal unwanted effects near edges or gradients. For situations where image fidelity is critical, Lanczos consistently delivers the most visually pleasing and accurate results. This makes it the recommended setting for professional installations where maximum sharpness, detail retention, and overall image quality are required.

5.5.5 Output Window (Advanced)

Bilinear Interpolation

- **How it works:** Averages the values of the four surrounding pixels to produce smoother transitions.
- **Result:** Soft, natural gradients with reduced visual artifacts such as ‘ringing’.
- **Best for:** Live video, photographs, branding, and signage that benefit from smooth color transitions.
- **When to use:** Suitable for photographic, video, or blended graphic content. Effective as a general-purpose option for large backgrounds and advertising visuals.

TIP: Bilinear interpolation is recommended over Nearest Neighbor when smoothness is important and the scaling factor is not a whole integer. Bilinear can fill in the gaps that Nearest Neighbor has issues with. It also helps prevent visual ‘ringing’ when performing small downscales by averaging nearest pixel values, rather than using a larger area filter (such as Lanczos). Bilinear is a safe, artifact-free choice for many practical situations, especially for video or graphics on LED displays.

Nearest Neighbor

- **How it works:** Copies the value of the nearest pixel without averaging or blending.
- **Result:** Pixel-accurate output with crisp edges but noticeable ‘blockiness’ when scaled up.
- **Best for:** Situations where preserving exact pixel values is essential, such as pixel art, technical grids.
- **When to use:** Best for maintaining clear, hard edges in stylized or technical visuals. It is well suited for situations where preserving pixel lines is of paramount importance. It is not well suited for photographs or natural imagery due to potential jagged appearance.

NOTE: When using Nearest Neighbor, for pixel-perfect results, always scale by whole integers (e.g., 2X, 3X, or 4X). This is so that each original pixel will line up cleanly with blocks in the output. If the multiplier is not a whole integer (e.g., 2.4X, 3.1X, 4.5X) pixels may be skipped or duplicated in irregular ways. Whole integer multipliers are key to retaining the exact structure and sharpness of the image. However, even with exact integer scaling factors (2X, 3X, etc.), each original pixel simply becomes a larger, solid-colored block. While this maintains the pixel-perfect structure that can look crisp for some content, it is still perceptibly ‘blocky’ compared to Lanczos. For photographs or natural images, this blockiness typically begins to stand out at multipliers of around 2X or higher, but can be objectionable at even lower multipliers depending on content, viewing distance, and display size.

5.5.6 Canvas Repeat - Output Window (Advanced)

Canvas repeat is useful in cases where multiple screens are driven from one processor and display the same content. Previously, the solution was to layer the mapping (one screen on top of the other). The canvas repeat feature duplicates the content across the canvas so that each display can be mapped in different regions of the canvas. The advantage is that this separates out the displays in space making it easier to interact with the maps of the various displays. In the example below, **Canvas repeat** has been enabled and numerous copies of the content are visible.

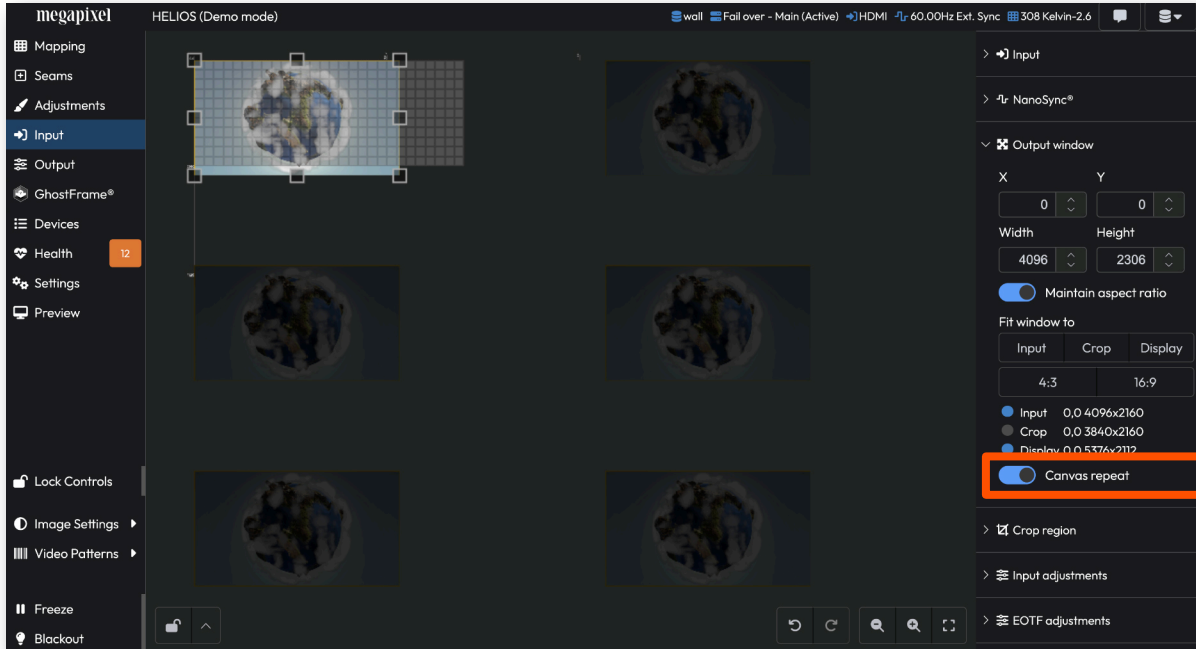

Figure 78: Output window

When **Canvas repeat** is enabled, the **Mapping** pane's tile positioning tools display **X (Local)** and **Y (Local)** controls above the regular **X** and **Y** position fields. Use local positioning to move tiles relative to the copy of the canvas that they are currently using. This tool aims to simplify the positioning of tiles. Each repeated canvas will start at local 0,0. The regular **X** and **Y** position fields can also achieve the same result, but these relate to the entire canvas so there is more math involved with discovering the desired canvas position.

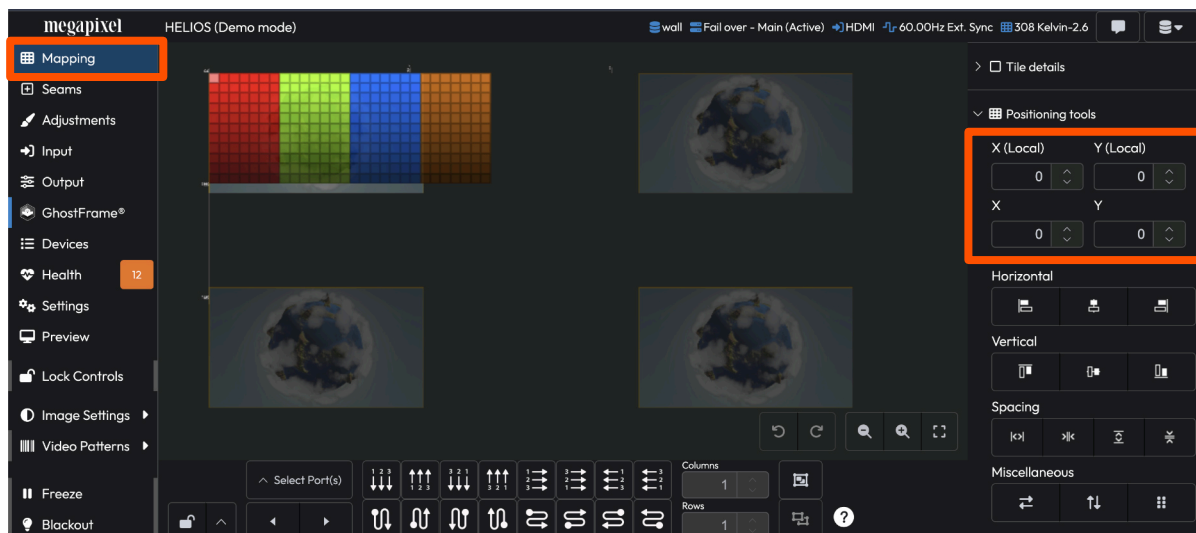

Figure 79: Output window

5.5.7 Crop region (Advanced)

Use the crop function on the **Input** pane to display a portion of an active input. Toggle the **Enable Cropping** function on, then enter the size and position coordinates for the crop region.

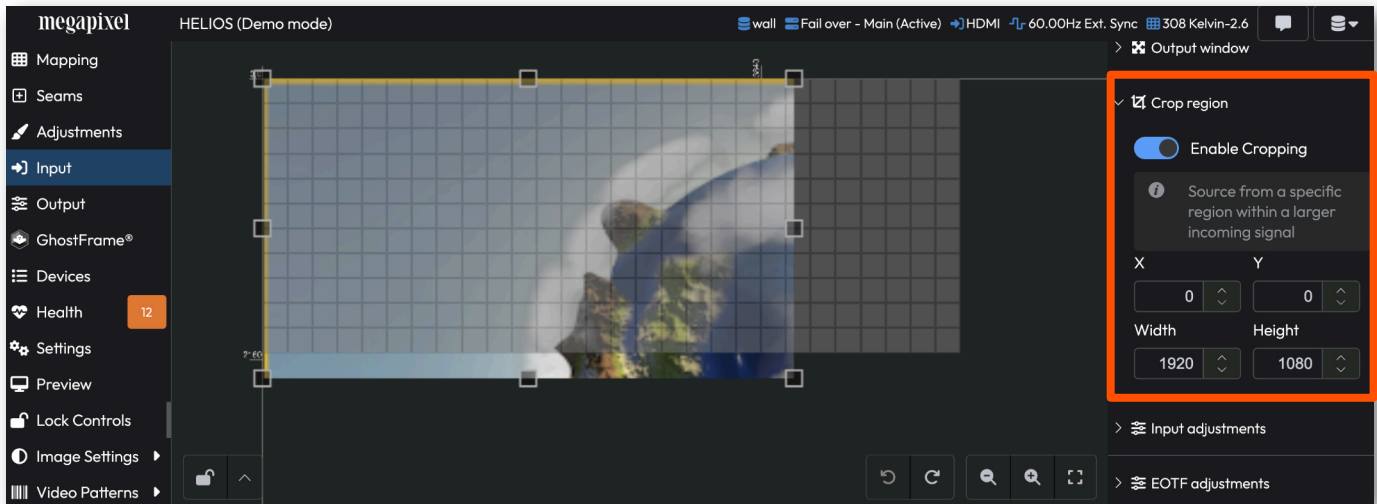

Figure 80: Crop region controls

Cropping is a load on the HELIOS® processor. For most common raster sizes cropping is not an issue. However, if a non-standard configuration is needed, ensure that the required pixel dimensions are within the 2.1G Pixels Per Second (PPS) limit of the HELIOS® crop and scale function. Calculate this with the following formula:

$$\text{pps} = \max(\text{inputActive.x}, \text{canvas.x}) \times \max(\text{crop.y}, \text{canvas.y}) \times (\text{inputActive.y} / \text{crop.y}) \times \text{fps}$$

inputActive — the active input video signal (e.g., 3840 x 2160)

canvas — the Output window size setting

crop — the crop size setting

The following are example configuration values:

Input: 3840 x 2160

Canvas: 5000 x 5625

Crop: 1920 x 2160

The following is the PPS formula using the values from above:

$$\begin{aligned} \text{pps} &= \max(3840, 5000) \times \max(2160, 5625) \times (2160 / 2160) \times 60 \\ &= 5000 * 5625 * 60 \\ &= 1,687,500,000 \text{ PPS (1.7G PPS*)} \end{aligned}$$

With the load calculation at 1.7G PPS, the configuration above is within the 2.1G PPS limit.

*This document uses SI prefixes, G = Giga (10⁹ or 1,000,000,000). This is different from IEC 'Xi' notation that is used for power of 2 units. In IEC 'Xi' notation, Gi = Gibibits (1,073,741,824). The 'i' means binary (2³⁰), not decimal (10⁹).

5.5.8 Input Adjustments

The input adjustments section allows the user to make visual changes (brightness, contrast, saturation) to each of the inbound signals independently. Input adjustment settings are saved separately for each input.

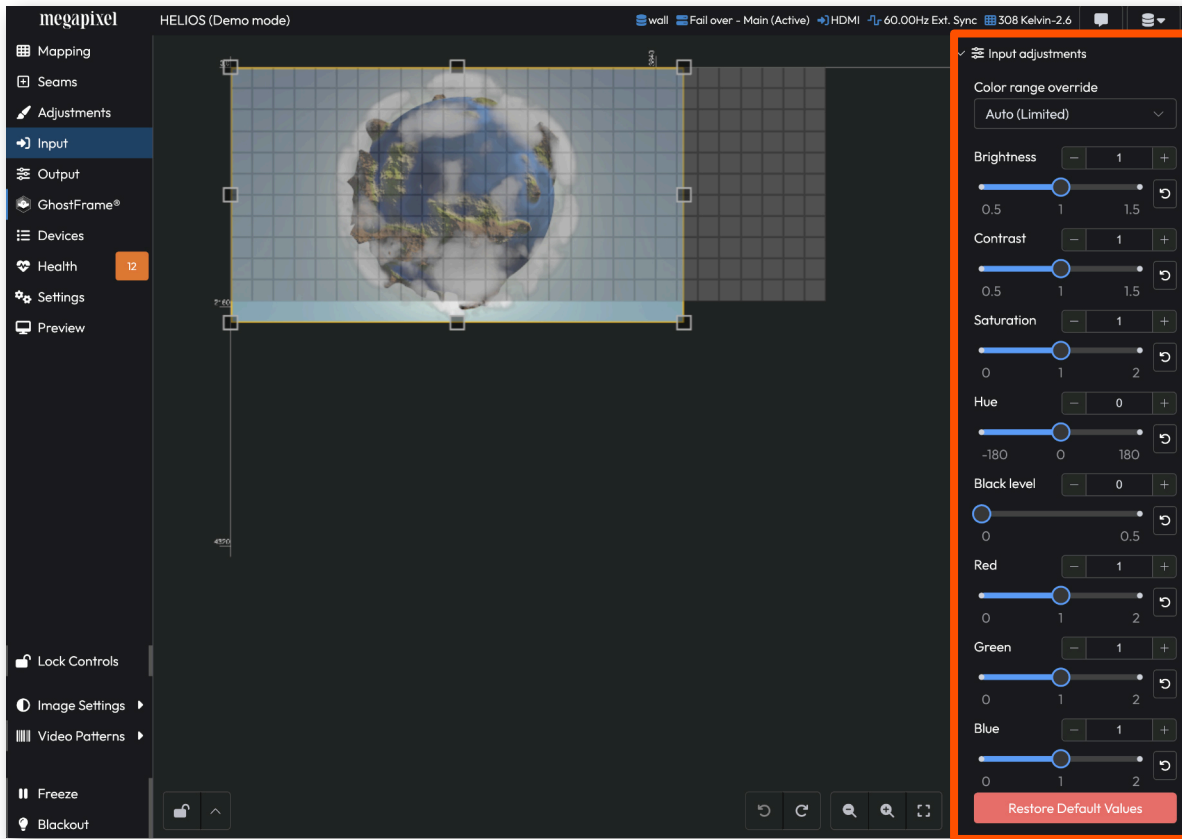

Figure 81: Input adjustments

Brightness — Adjusts the inbound image to be lighter or darker. First, adjust the brightness to reproduce black correctly then, contrast.

NOTE: This brightness control adjusts the inbound video brightness and should not be used for adjusting the luminance of the display.

Contrast — Increases or decreases the differences in brightness across the image.

Saturation — Increases or decreases purity of colors. Full desaturation turns colors gray.

Hue — Changes the color of the video, re-mapping it around the color wheel.

Black level — A combined brightness + contrast control. See [Low Level Noise Reduction](#) in Appendix D for how this control is used to eliminate low level noise in an image.

RGB gains — Boost or reduce the amount of Red, Green or Blue in the image. Note that these controls are intended for content correction/tweaking. To adjust the RGB levels of the display it is recommended to instead use the **Output > RGB Gains**.

5.5.9 Input Adjustments (Advanced)

With [Advanced Mode](#) enabled, the **Color range override** controls will appear as well as the **EOTF adjustments** accordion

Color range override — Defines how to interpret the levels of values in the video signal. The range of values used to interpret the video is defined by two quantization ranges, **Auto (Limited)** and **Full**. **Auto (Limited)** video content is contained within (16 - 235) standard for video. In the limited range, 16 and below is treated as pure black and (235 - 255) is treated as pure white. **Full** range video content uses the full (0-255) range (pure black is 0 and pure white is 255). The way that HELIOS® interprets the video must match how it was encoded. If this isn't set correctly there can be a complete loss of shadow detail or conversely, washed out highlights. If **Auto** does not identify the encoding correctly, use this toggle to make a manual selection.

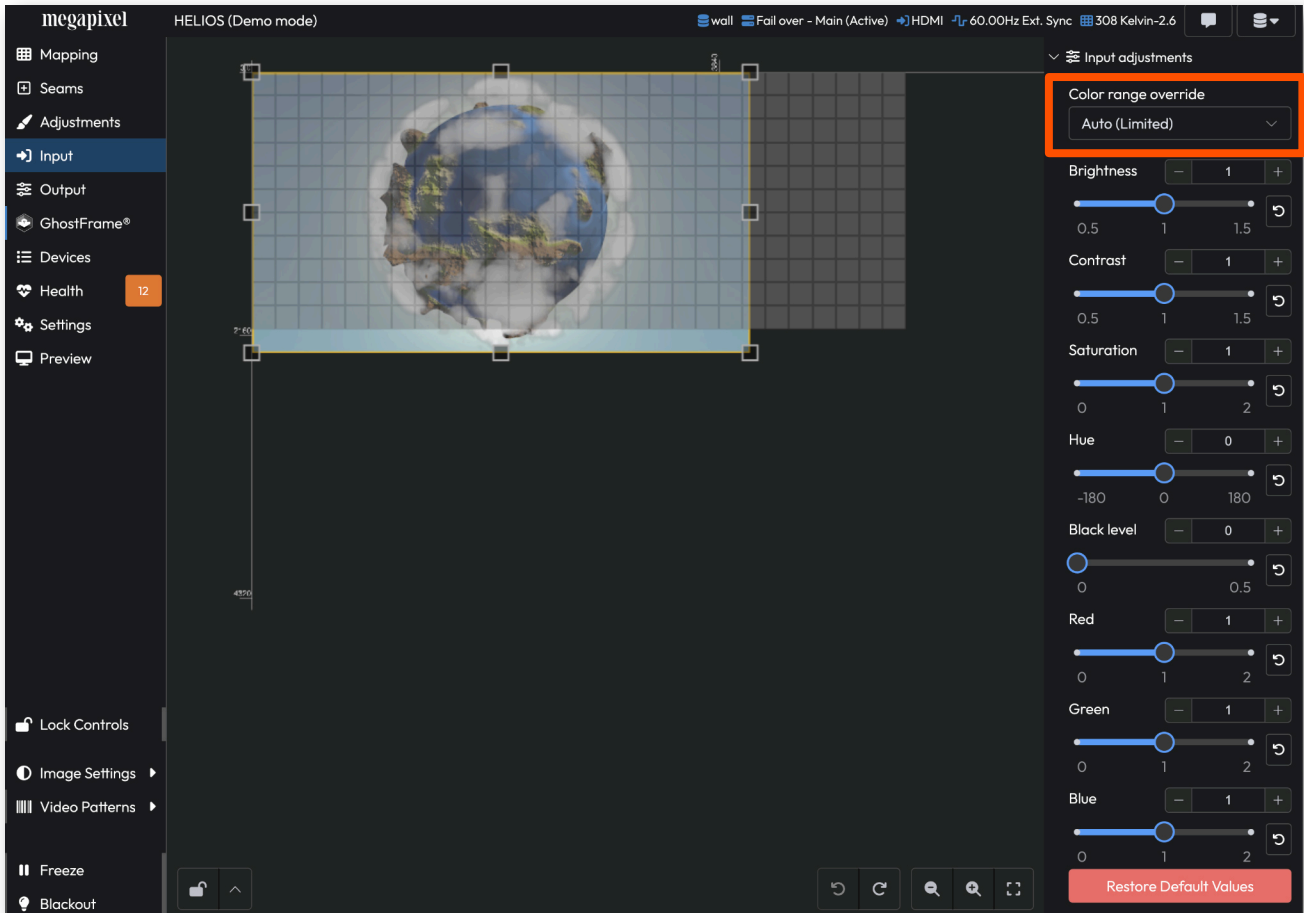

Figure 82: Color range override

5.5.10 EOTF Adjustments (Advanced)

The HELIOS® EOTF (Electro-Optical Transfer Function) adjustments are used to inspect and manually override EOTF settings encoded in the source signal's metadata. If content has a standard dynamic range, it should be interpreted with one of the two SDR options; **SDR (Preserve Details)** or **SDR**. **SDR (Preserve Details)** uses the sRGB curve while **SDR** uses the RAW curve. The correct selection depends on the content. Content encoded with a high dynamic range should be set to the EOTF with which it was mastered. Most HDR content will have a metadata label indicating which transfer function was used. HELIOS® with default settings, should automatically recognize and select the correct EOTF for the content.

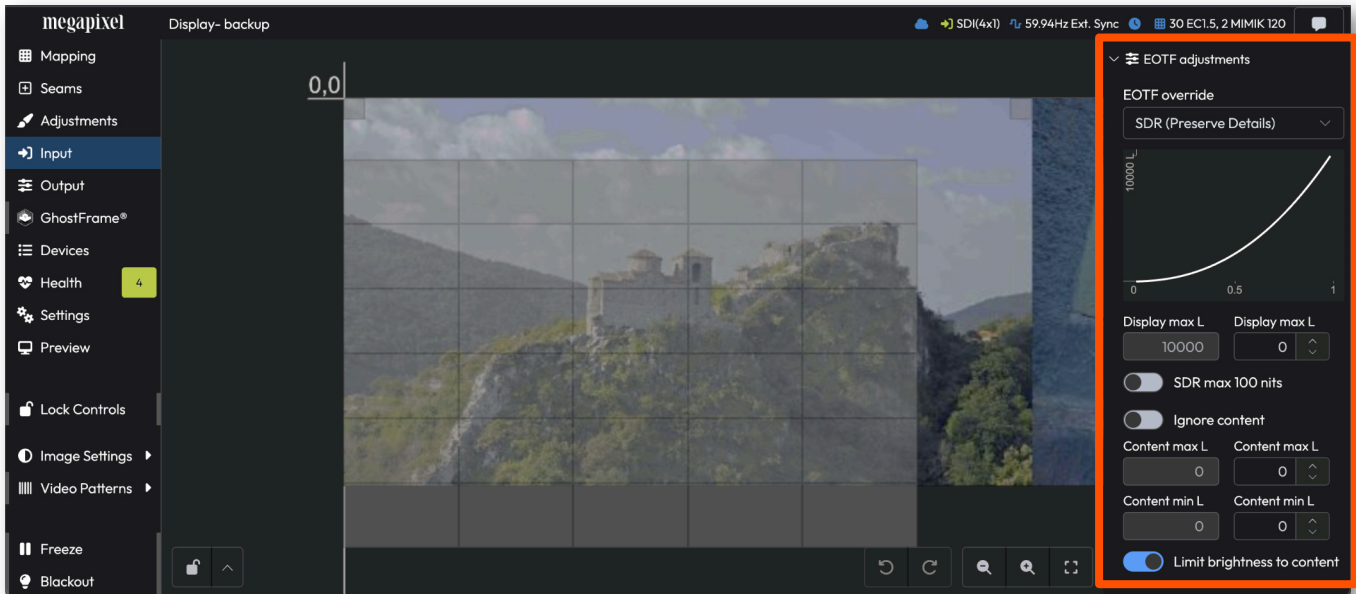

Figure 83: EOTF adjustments

EOTF override — If HELIOS® reports that a PQ signal is SDR when set to **Auto (SDR)** it is possible upstream equipment has stripped the PQ metadata. Use the EOTF override setting to manually set HELIOS® correctly.

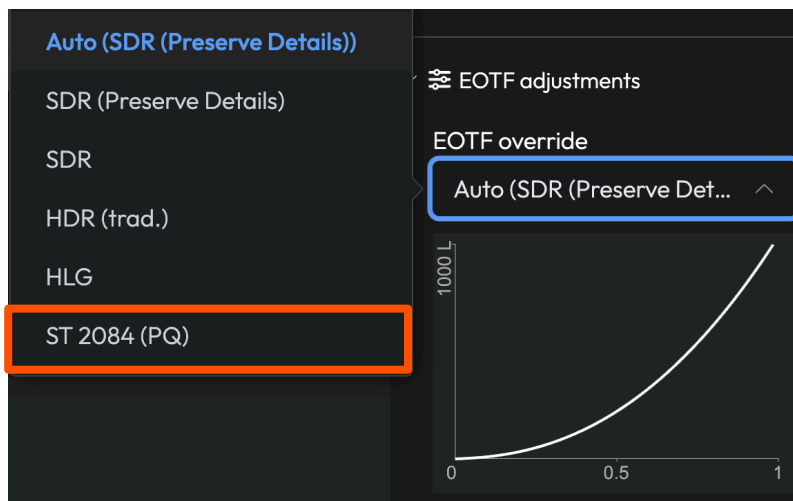
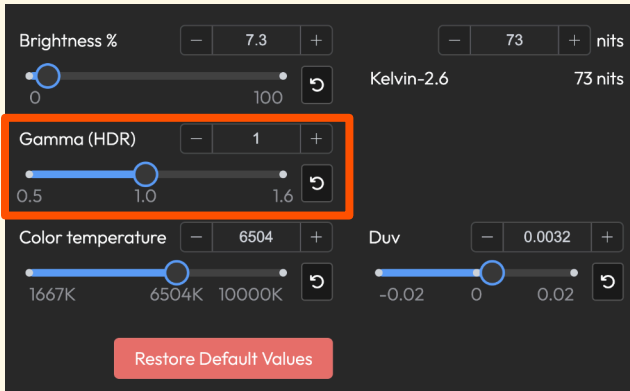

Figure 84: EOTF override

5.5.10 EOTF Adjustments (Advanced)

NOTE: The visible slider range for global Gamma is re-mapped when HELIOS® is operating in HDR so that a nominal PQ gamma is reported as 1.0. In SDR mode, the nominal value for Gamma is 2.4.



HDR

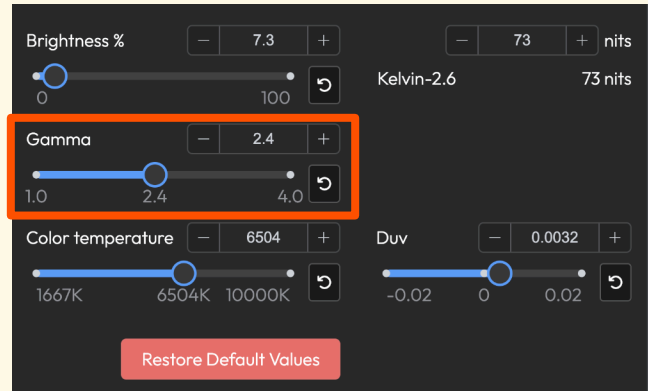

SDR

Display max L, **Content max L**, and **Content min L** are read only values on the left side with manual override fields to the right. Advanced users may enter specific numbers here. If the correct values are not known, keep the field values at zero. The system is in automatic mode when these values are at zero. If non-zero values are entered, keep Advanced Mode **ON** so that the values affecting the system are visible.



Figure 85: Advanced Mode adjustments

5.5.10 EOTF Adjustments (Advanced)

The PQ curve is defined in nits. As such, PQ content reports a max L (luminance) to HELIOS®. In other words, PQ content needs to be displayed at the brightness level at which it is mastered. The graph below the dropdown is provided to help explain the relationship between the Content max L and Display max L. If there is a max L mismatch between the content and the display, the graph shows how the mismatch is being handled.

Example (A) — Display max L and Content max L are both 10,000 nits.

Example (B) — Display max L is 10,000 nits, Content max L is 1,000 nits. HELIOS® can show all the content directly 1:1.

Example (C) — Display max L is 1,000 nits, Content max L is 10,000 nits. HELIOS® introduces roll-off to preserve highlights.

Example (D) — HELIOS® will also show the curves of SDR and other supported transfer functions.

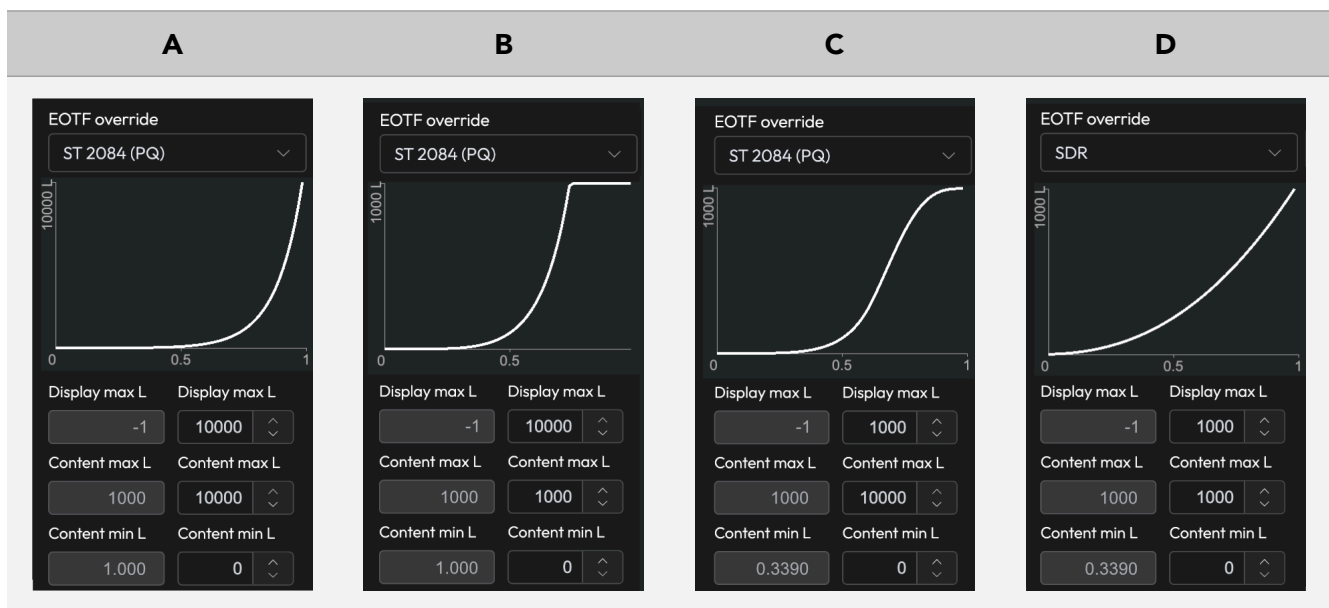

Figure 86: EOTF max L graph examples

NOTE: Video routing equipment can change the color range metadata on an input signal. It is good practice to manually set HELIOS® onto the correct setting.

5.5.10 EOTF Adjustments (Advanced)

SDR max 100 nits — a toggle to keep the brightness of SDR content at 100 nits regardless of what the global brightness is set to. Keeping SDR at 100 nits preserves the intended contrast, color appearance, and camera exposure behavior, especially in virtual production and studio environments tuned for Rec.709. The toggle gives a quick, repeatable way to jump between ‘reference SDR’ and ‘venue brightness’.

Ignore content — a toggle to ignore the metadata embedded in the content. With this on, HELIOS® assumes content is mastered for the display and will not make changes to the way the content is displayed as new metadata is available. Consumer set-top sources often adjust the content metadata when the user moves between menus, screensavers, and actual video. This can cause visible brightness and contrast shifts. With this toggle on, HELIOS® will ignore those changes.



Figure 87: SDR max 100 nits and Ignore content

Limit brightness to content — a toggle for cases where the content’s brightness information is not desired. If PQ encoded content calls for a level that exceeds the capabilities of the tiles, the limit will be the tile’s maximum brightness. If tiles are being limited by PQ encoded content and a brighter display is needed, turn OFF the toggle. The HELIOS® will ignore the content brightness and allow the tiles to reach their max brightness.

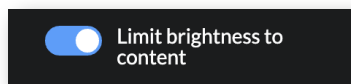

Figure 88: Limit brightness toggle

5.5.10 EOTF Adjustments (Advanced)

Key points:

- PQ is currently the only signal type that both advertises and utilizes content light level information.
- HLG signals use display maximum luminance but ignore content light levels.
- For SDR and traditional HDR signals, the numerical content light level fields are not used.
- Display max luminance is always determined by the connected tiles.
 - Tiles continue to respect the **Output > Output adjustment > Limit to lowest tile max** setting.
 - If this setting is not enabled, all tiles operate at the same brightness, regardless of EOTF.
- The image settings pop-up will notify the user when either **Limit brightness to content** or **Limit to lowest tile max** is active. For example: If HELIOS® receives a PQ signal with content max luminance set to 100 nits and tile max luminance is 500 nits, the **Image Settings** window displays **Limited by content** under the nits value.
 - If the EOTF is switched to a mode where content max luminance is not used, this notification will disappear from the input settings.

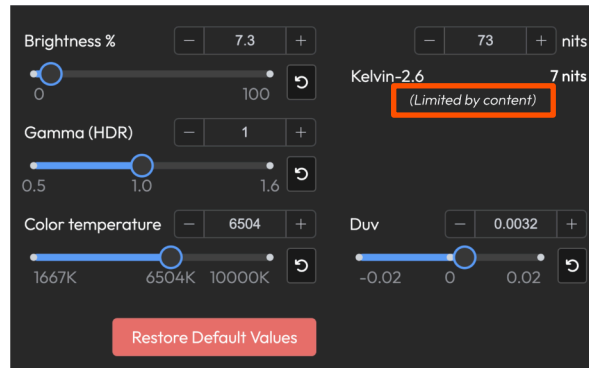

Figure 89: Limit message

NOTE:

- When the content level is unknown or not advertised, content max L is assumed to be the same as display max L. In other words, content is assumed to have been mastered for the display.
- In the case of mixed tile types, brightness is restricted to the tile type with the lowest peak brightness. Mixed tile type systems are not recommended.
- Please see Appendix E for more information on [Content to Panel Luminance Curves](#).
- HELIOS® is the signal transformation stage of the HDR pipeline. For tone mapping to work correctly, only one tone mapping stage should be active across the full pipeline — at the media server or at HELIOS®, not both. If the EOTF reported by HELIOS® does not match the mastering transfer function of the content, all downstream rendering decisions will be based on incorrect assumptions. See [Appendix J](#) for a full discussion of HDR pipeline best practices.

5.5.11 Signal Transformation Best Practices

HELIOS® is the signal transformation stage of the HDR pipeline. Its role is to perform a single, intentional conversion from the source signal to the display. To maintain HDR integrity at this stage:

- Ensure only one tone mapping stage is active across the full pipeline.
- Avoid redundant or hidden processing steps. Review all EOTF, color range, and gamut settings together — these controls interact.
- Validate EOTF alignment at the processor level. Confirm that the EOTF reported by HELIOS® matches the transfer function used to master the content.
- Monitor Delta E (color error) introduced during processing. Use the Tile Calibration Report (Output pane > Report) to verify that the system is reproducing color within acceptable tolerances.

NOTE: Delta E (ΔE) is a measure of perceptual color difference. A Delta E of less than 1.0 is generally imperceptible. Values above 3.0 are visible to the eye. When validating HDR output, combine Delta E measurement with visual inspection of highlight roll-off and shadow detail — measurement and perception can diverge and both should be checked.

5.5.12 High Dynamic Range

HDR on HELIOS® is comprised of several features all working together: bit depth, gamut, and decoding with an HDR transfer function. Standard definition content uses the typical SDR gamma curve. HDR uses an entirely different function to map a higher range of brightness onto a display. HDR is more than just brightness, it also includes a wider range of colors. As such, the system must use, at minimum, 10-bit color. HELIOS® should ideally be set to 12-bit if possible. Check that the bandwidth is sufficient under the **Outputs** pane **Display bit depth** accordion.

A true HDR end result requires that the entire pipeline, from content to wall, is aligned and capable of supporting HDR.

HDR Checklist:

1. The tiles must be capable of a wide gamut.
2. Output gamut needs to be set to Automatic (see the Output pane Display gamut accordion).
3. Content must be encoded in HDR.
4. The playback device must support HDR.
5. HELIOS® must receive the signal and recognize it as HDR. Check under the disclosure triangle to see the details of the input signal. In the example below, HELIOS® is receiving a PQ signal. If an HDR input signal is not recognized as HDR, use the manual override discussed on the next page.

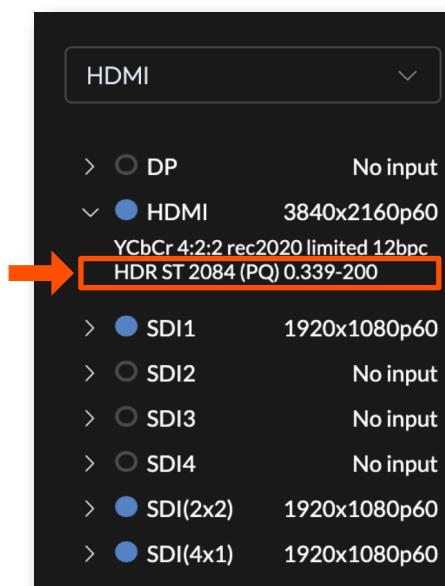

Figure 90: Input signal info

NOTE: When connecting consumer playback equipment such as an Apple TV or an Xbox to be an input source be mindful that these units default to a 4:2:0 color scheme. HELIOS® does not fully support 4:2:0. When HELIOS® receives a 4:2:0 color signal, it will send a black and white image to the tiles. Set the input source to 4:2:2 to regain full color operation.

5.5.12 High Dynamic Range

TIP:

Unreal Engine

Metadata may indicate an SDR signal when Unreal Engine is transmitting PQ content. Unreal Engine takes over the configuration of the outbound video because Unreal Engine prefers to be in control of the encoding entirely in-engine. The Windows video output needs to remain set to SDR. This will cause the HELIOS® to think that the signal is SDR. If Windows HDR mode is set, it applies an additional encoding to the signal, which is like double-LUTing.

HELIOS® Settings

- Set the EOTF override to PQ.
- Set the Color range override to Full.

Unreal Engine Windows Output Settings

NVIDIA Control Panel > Output resolution settings

- The radio button for Use NVIDIA Settings is selected.
- Desktop color depth = 30 bit color
- Output color bit depth = 10 bpc
- Color output format = RGB
- Output dynamic range = full

5.6 Output Pane

5.6.1 Display Gamut

The display gamut tool sets the range of each color for the system using CIE 1931 chromaticity (x & y) coordinates. Common preset gamuts are available from a dropdown menu. HELIOS® is set to **Auto (Rec. 2020)** in the example below. Just because a system has been set to certain color targets does not mean tiles are performing at those values. The **Target** tab shows the values the system is set to. The **Actual** tab shows tile performance. This data is also represented visually on the dynamic CIE chart.

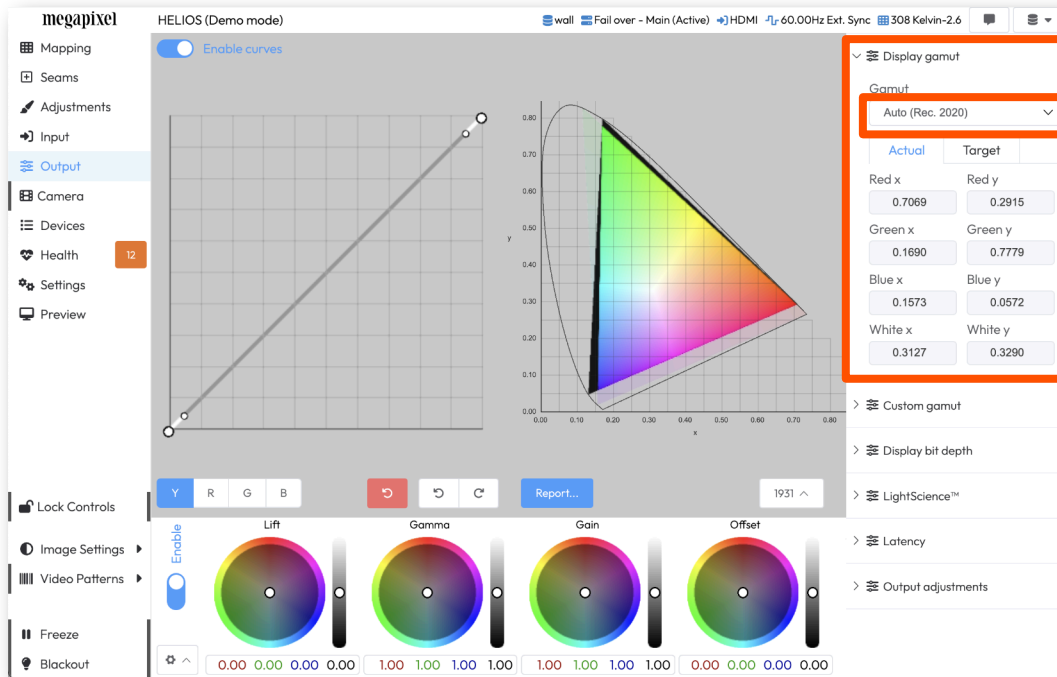
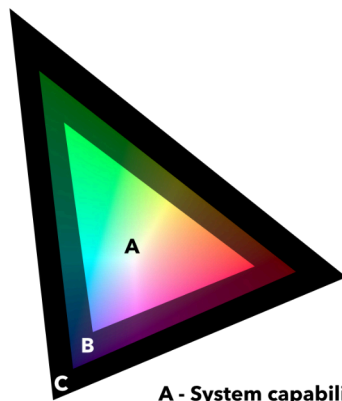

Figure 91: Display gamut

On the CIE chart, tile capabilities are indicated by the entire rainbow region, **A + B** (both transparent and opaque regions). The achievable colors for a system are indicated by the **A** center opaque rainbow region. Lastly, a black region **C** indicates colors targeted by the settings that are beyond the capability of the display. If the color targets are set within the display capabilities, this black region will not appear.



- A - System capability (tile and system settings)**
- B - Tile capability**
- C - Out of range (tile and system settings)**

Figure 92: Display gamut chart key

NOTE: When a system is made up of more than one tile type, wide gamut can be color restricted by narrow gamut tiles. When a system is made up of mixed tile types, HELIOS® is automatically set to Widest gamut. HELIOS® will determine the widest possible gamut from all connected tiles. This can result in a lowest common denominator color target selection; tiles with wider gamut capabilities will be restricted to the more narrow gamut setting to match all tile capabilities.

5.6.2 Calibration Report

HELIOS® can generate a **Tile Calibration Report** for a system. Press the blue **Report...** button to open the report in a new tab.

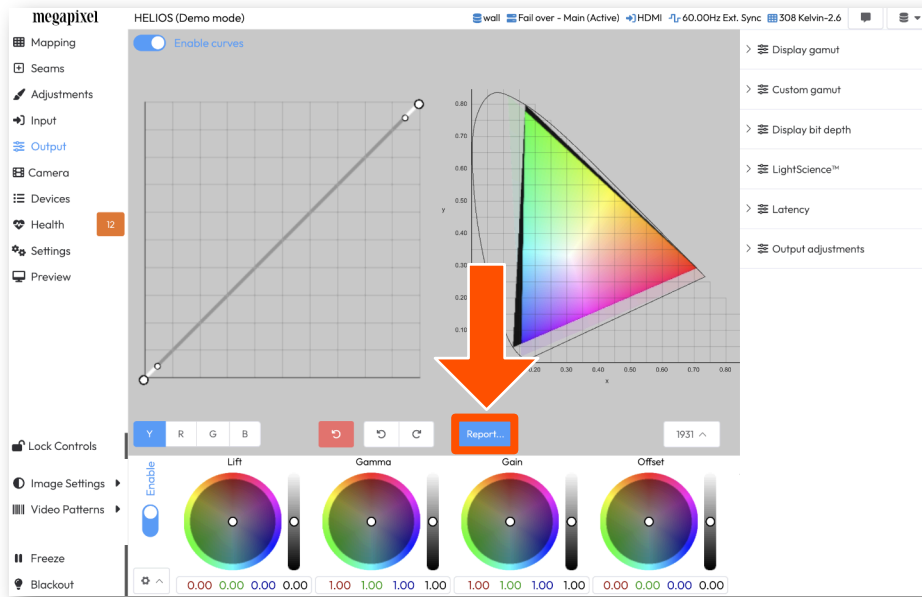

Figure 93: Calibration Report button

The Tile Calibration Report (shown below) is useful for content creators and colorists who need to know the color capabilities of the system. Use the zoom controls (orange rectangle below) to inspect the CIE chart in more detail.



Figure 94: Tile Calibration Report

5.6.3 Validating HDR Display Performance

The Tile Calibration Report provides the data needed to assess whether the display is performing at the level required by the HDR content. Review the Tile Calibration Report for gamut coverage percentages against Rec.2020, DCI P3, and Rec.709. For a more rigorous commissioning check, perform a Delta E measurement. This requires external instrumentation such as a colorimeter — the report does not provide Delta E values directly.

What to Check

- Target vs. Actual gamut: Compare the Target and Actual tabs in the Display Gamut accordion. If the Actual gamut is significantly narrower than the target, the tiles may not support the full color range expected by the content.
- Black region on the CIE chart: If a black region (C) appears on the CIE chart, the color targets are set beyond the capability of the display. Adjust the gamut target or accept that those colors will be clipped.
- Delta E tolerance: Calibration maintains color consistency across panels. Acceptable Delta E thresholds vary by tile type and installation context. Confirm the acceptance criteria for your specific system with Megapixel before signing off on an installation. Regular recalibration is required to control Delta E variation as display performance changes over time.

Display Alignment with Content

The display is the final stage of the HDR pipeline. Its capabilities define the perceptual ceiling of the system — no amount of upstream quality will recover information the display cannot reproduce. When evaluating HDR performance:

- Confirm that the display's peak luminance capability matches the mastering target of the content. If content is mastered at 1,000 nits and the tiles peak at 800 nits, HELIOS® will introduce roll-off to handle the mismatch (see the [EOTF Adjustments](#) luminance curve graph in Section 5.5.10).
- Calibrate white point to D65 for consistent color appearance across panels and alignment with standard HDR mastering environments.
- In mixed tile systems, HDR performance is constrained by the lowest-capability tile. Mixed tile configurations are not recommended for critical HDR workflows.

TIP: Content creators and colorists can use the Tile Calibration Report to understand the color capabilities of the system before finalizing HDR grades. Sharing the report early in the workflow prevents mismatches between content mastering assumptions and display performance.

5.6.4 Custom Gamut (Advanced)

HELIOS® supports custom gamut settings. Enable **Advanced Mode** under **Settings > Processor Settings > Advanced** to reveal the **Custom gamut** accordion.

1. Set the chromaticity coordinates in the **Custom gamut** accordion.
2. Press **Apply custom gamut**.
3. Select **Custom gamut** from the **Gamut** dropdown. The chromaticity coordinates under the **Target** tab should match the custom gamut values.

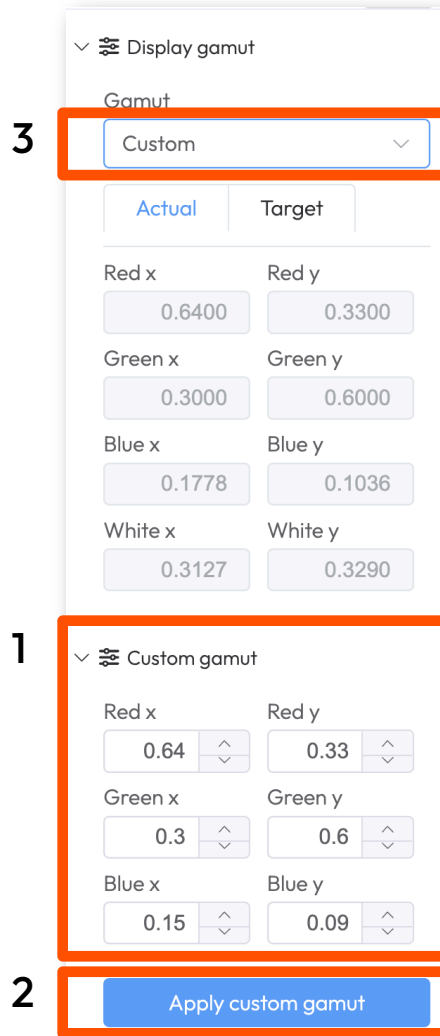

Figure 95: Custom gamut settings

5.6.5 Display bit depth

The system can operate at 10-bit or 12-bit. This menu controls the current setting and shows per-port bandwidth percent utilization. 12-bit operation is recommended. Selecting 10-bit operation will reduce bandwidth utilization.

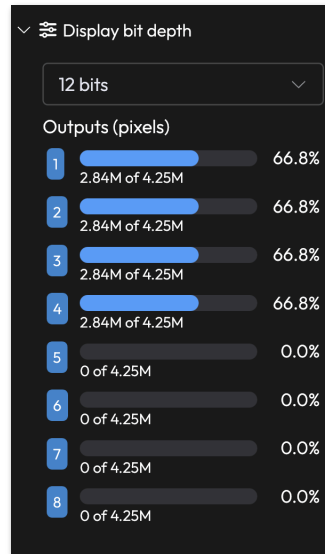

Figure 96: Display bit depth

5.6.6 LightScience®

Low light levels and shadow detail can be challenging for LED displays to reproduce. HELIOS® can significantly improve the visual appearance of these near-black video regions by expanding the bit depth of each tile. With LightScience® enabled, the proprietary algorithm will expand bit depth per color channel to between 21 and 32 bits.

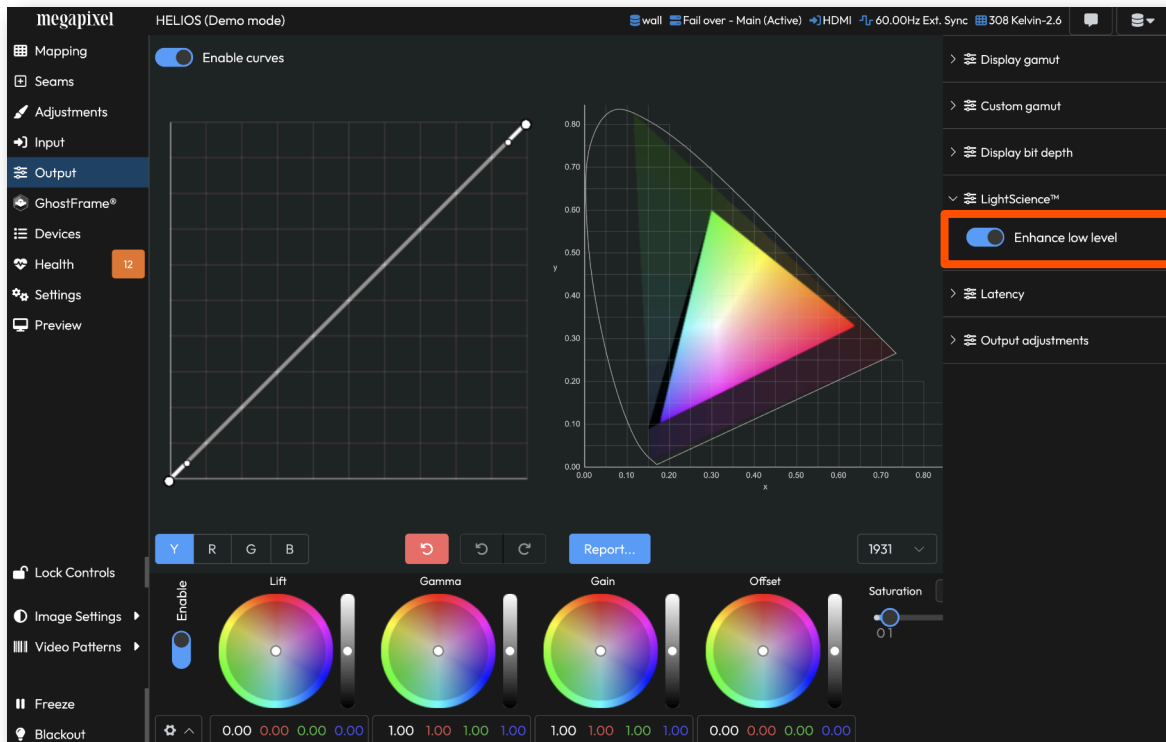

Figure 97: LightScience®

5.6.7 Output Pane (Advanced)

With Advanced Mode enabled, HELIOS® displays two separate interfaces for color grading, a curves graph and a set of color wheels. In the HELIOS® processing pipeline, these two tools are applied sequentially. Any adjustment made by the color wheels will come first, followed by the curves. Below is a simplified color processing pipeline diagram for the entire HELIOS® system.

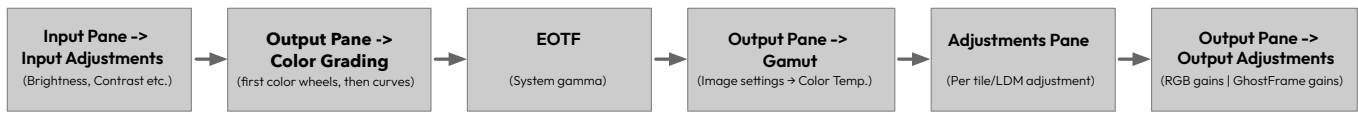

Figure 98: HELIOS® color processing pipeline

5.6.8 Color grading tools - Color wheels

In addition to curve controls HELIOS® has four color wheels for adjusting **Lift**, **Gamma**, **Gain**, and **Offset**. Each color wheel controls a particular range of tones (shadows, mid-tones, and highlights). When the position of the point on the color wheel is adjusted, HELIOS® shifts the hue of the tones towards the selected color. Use the gray slider next to the color wheel to adjust the color brightness.

Lift — Dark tones and shadows

Gamma — Mid-tones

Gain — Highlights

Offset — Overall image control

Saturation — Increases or decreases overall purity of colors. Full desaturation turns colors gray.

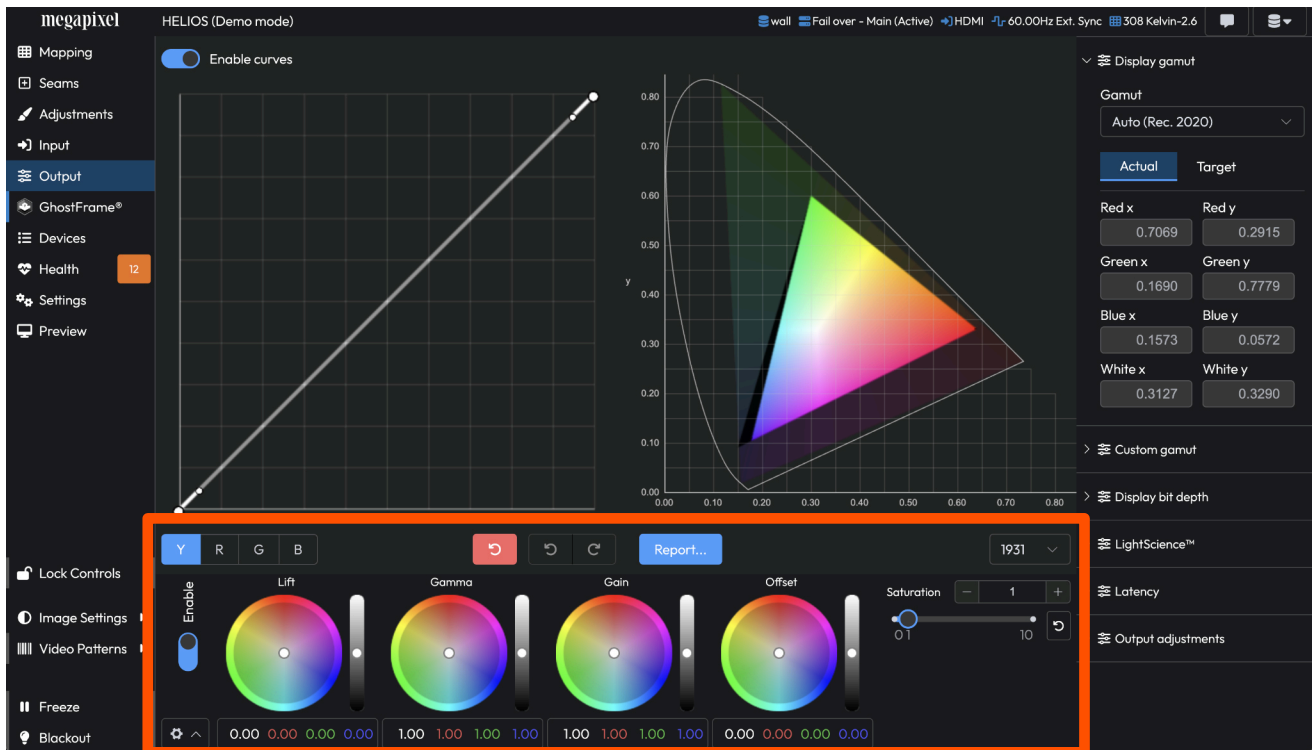

Figure 99: Color grading color wheels

5.6.9 Color grading tools - Curves

HELIOS® offers curve control for luminance (**Y**) and the primary colors (**Red**, **Green**, and **Blue**). Select which curve to control from the **YRGB** radio buttons at the bottom of the curve graph.

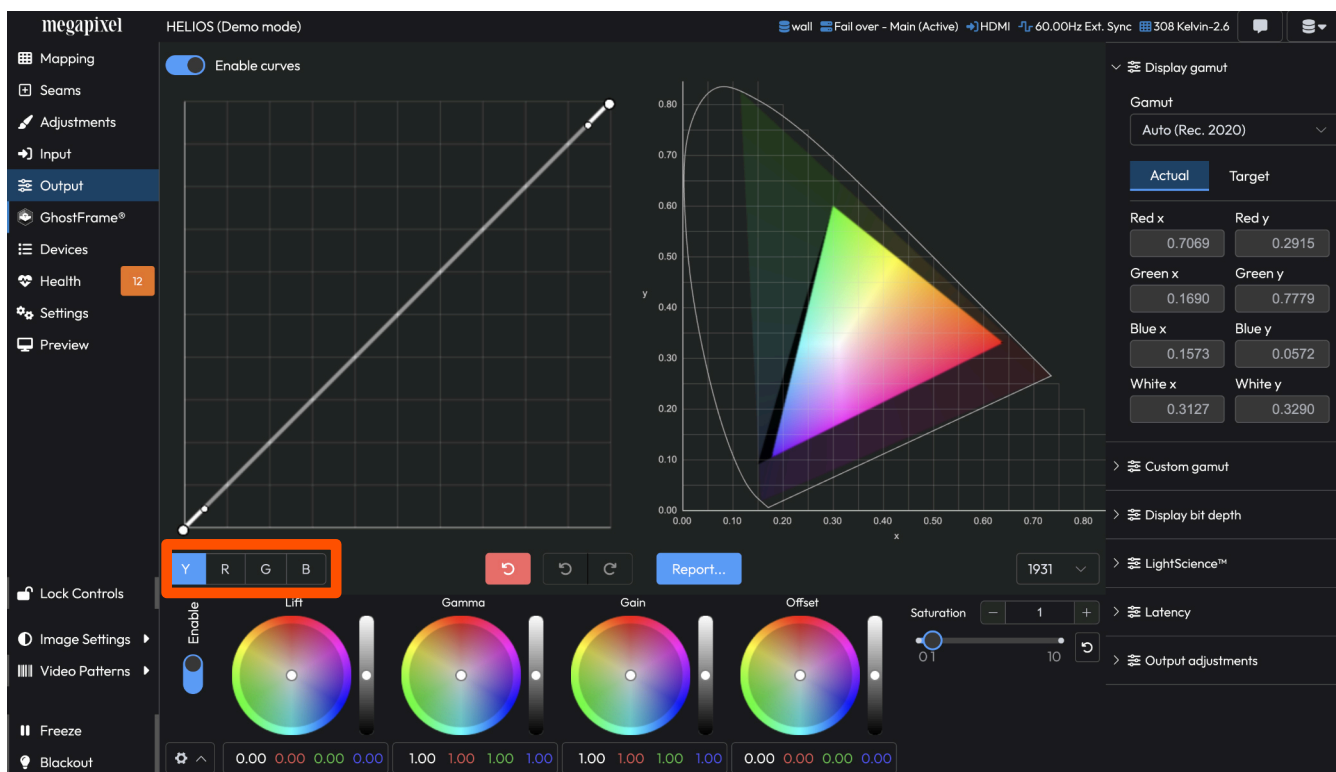

Figure 102: Color grading curves

5.6.9 Color grading tools - Curves

The curve controls provide adjustment of the image based on tonality regions. The bottom of the graph represents the shadows, the middle are the mid-tones, and the top the highlights. Highlight and shadow points exist by default. Click on the graph to create additional region control points. Place region control points at the boundaries of regions to isolate tonalities. Move the region control point up/down to adjust the region lighter/darker.

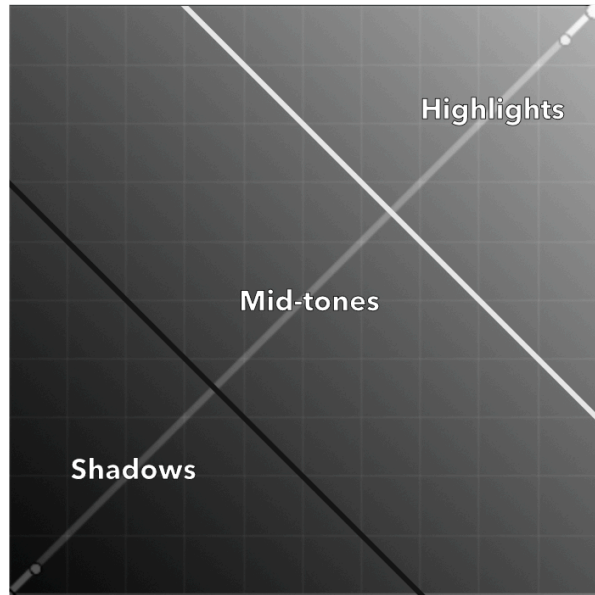

Figure 100: Control regions

Region control points have a transition control handle. In the example image below, the red arrow is pointing at the region control point. The green arrow points at the transition control. The slope of the transition control sets the steepness/smoothness of the transition into and out of a tonal region.



Figure 101: Control point slope

5.6.10 Ultra Low Latency (Advanced)

HELIOS® Ultra Low Latency (ULL) reduces system delay to as low as one (1) frame through the entire signal chain, without requiring custom EDIDs or high frame rates from the source. To access ULL, enable [Advanced Mode](#) — a hidden accordion will appear in the **Output** pane.

ULL uses two independent toggles:

- **Tile low latency** — reduces latency by up to one (1) frame. Requires tile-side support; check the tile manufacturer's specifications.
- **Processor low latency** — independently reduces latency by one (1) frame. Stacked column restrictions apply (see next page).

Enabling both toggles reduces total system latency by up to two (2) frames. When both are active, the latency display should report 1.0 frame.

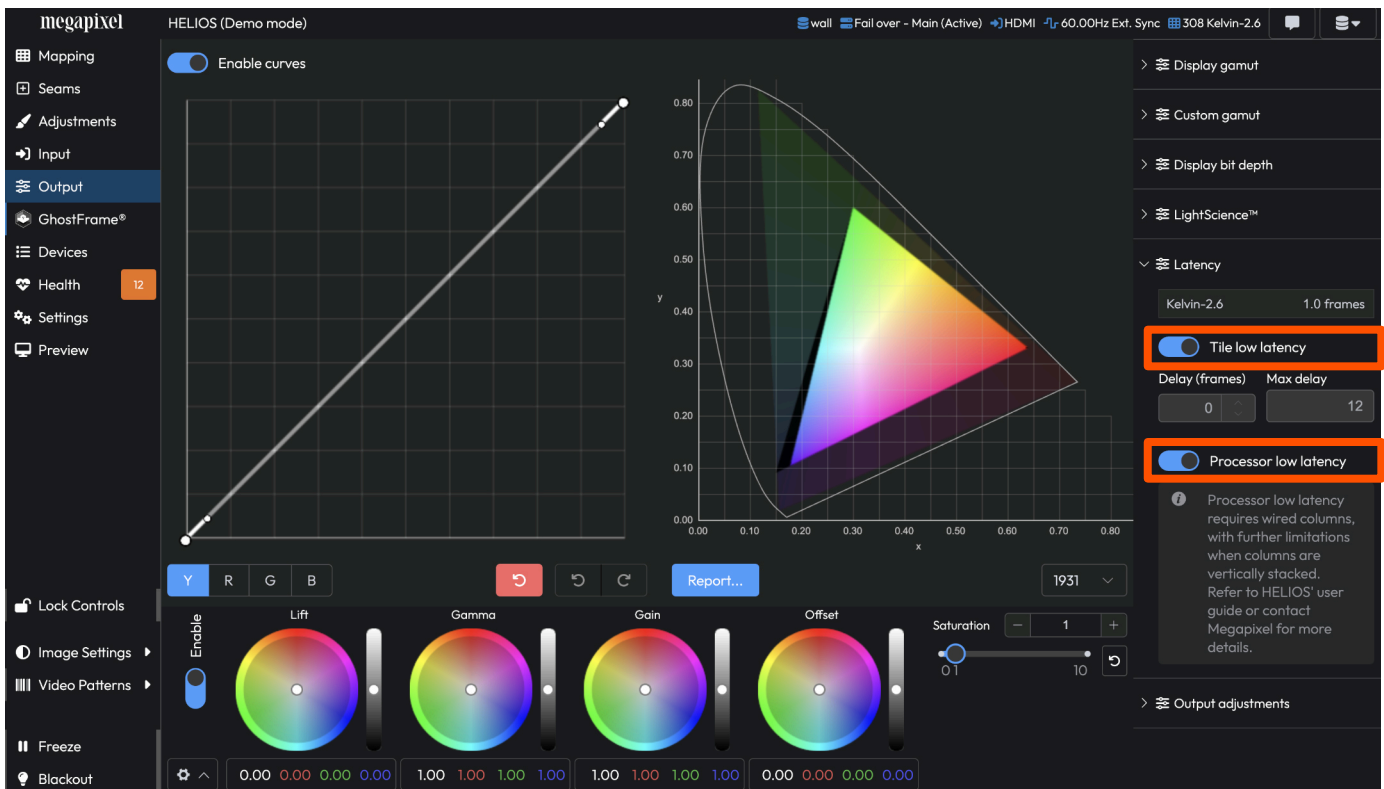

Figure 103: Ultra Low Latency settings

5.6.10 Ultra Low Latency (Advanced)

Key rules:

- Processor Low Latency is compatible with GhostFrame®. When using multiple inputs with GhostFrame® Multi-Source, the inputs must be horizontally stitched. As an example, configure SDI as a (2x1) rather than a (1x2). See [Section 5.5.1](#) on Input stitching for more information.
- Vertical stitching of inputs and Square Division are not supported.
- Tile cabling and mapping must be in columns (top to bottom and bottom to top are both acceptable).
- Single columns — there are no capacity limitations or reductions when tiles are cabled as a single column. This is the optimal system configuration. Therefore, tile quantity per daisy chain is no different than normal operation (see the HELIOS® Output Port Capacity section in [Appendix K](#) for data daisy chain limits). In the example below, the tile type has a maximum daisy chain of six (6) tiles. Although some tile types can achieve larger daisy chains, this example is limited to six (6) for simplicity. The red daisy chain arrows in the example below indicate the tile to tile connections.

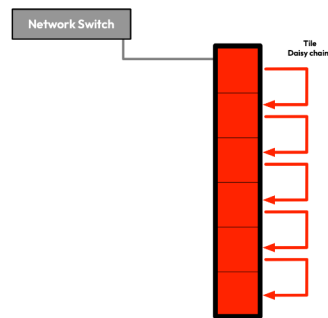

Figure 104: Single column example

- Stacked columns — a wall that is taller than the maximum tile chain length. Stacked columns have capacity reductions. The rule of thumb is that when columns are stacked, the maximum string length is halved from that of normal operation. The example tile type at normal operation has a maximum daisy chain of six (6). In a stacked configuration, this example system requires chains of three (3) tiles. Additionally, only the top ½ of the input may be used. Each different colored tile in the example below represents a connection to a different switch port. As an example, red tiles could be on port 1, green tiles on port 2, and blue tiles port 3. The red, green, and blue tile daisy chain arrows show the tile to tile connections.

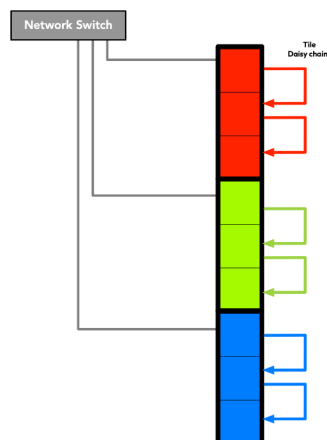

Figure 105: Stacked columns example

5.6.10 Ultra Low Latency (Advanced)

Key rules (continued):

- Interleaved columns — tiles are cabled from separate switch ports in an alternating pattern. This maximizes the usable canvas and chain length, significantly reducing (and in some cases completely eliminating) the half chain and half canvas limitation. The interleaved configuration is the optimal multi string system configuration for reducing latency. The red, green, and blue tile daisy chain arrows show the tile to tile connections.

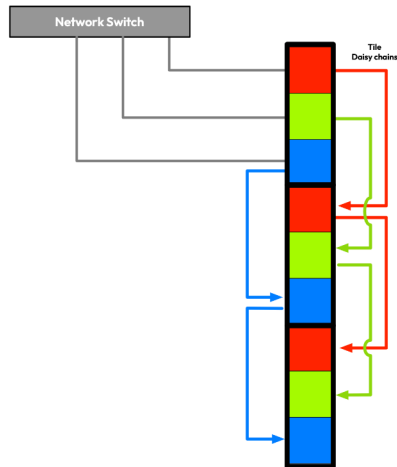



Figure 106: Interleaved columns example

- When using Processor Low Latency (PLL), the **Sync delay** on the **Input** pane under **NanoSync®**, needs to be set to zero (0).

To help transition a system from stacked columns to interleaved columns the HELIOS® processor has a vertical interleave button  on the mapping pane. Tiles must be configured in stacked columns as in the example on the left. Press the interleave button to have HELIOS® automatically re-arrange the tiles.

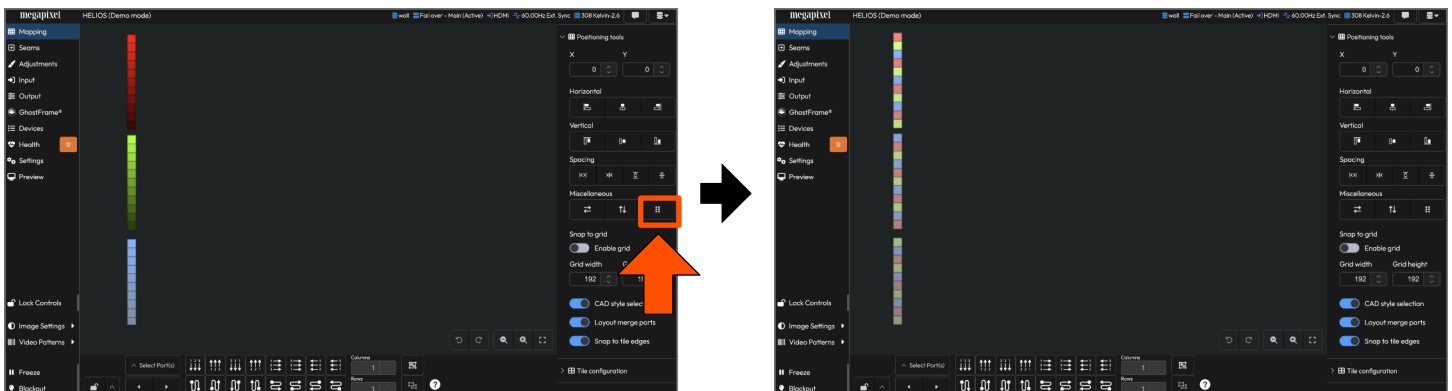

Figure 107: Mapping Interleave

5.6.10 Ultra Low Latency (Advanced)

Below are four test results with Low Latency off and on. Using the SDI output of an ImagePRO-II* connected to the HELIOS® system, the yellow line measures a phototransistor reading the tile's light output. The green line measures the HD-15 (VGA) output of the same ImagePRO-II connected directly to the scope.

Yellow — ImagePRO-II 720p50 -SDI → HELIOS® → Tile → Scope (photo transistor)

Green — ImagePRO-II -HD15→ Scope



Figure 108: Ultra Low Latency oscilloscope readings

Top left image — Both (HELIOS® and tiles) LL toggled OFF. Results show three (3) frames delay.

Top right image — Only the HELIOS® LL function ON. Results show two (2) frames of delay.

Bottom left image — HELIOS® LL OFF and tile LL ON. Results show two (2) frames of delay.

Bottom right image (Orange) — Both (HELIOS® and tiles) LL toggled ON (This is Ultra Low Latency enabled). Results show one (1) frame of delay.

* The ImagePRO-II is a registered trademark of Barco.

5.6.11 Output adjustments (Advanced)

RGB gains — Controls overall tile color gain. This is the final color adjustment point in the HELIOS® color processing pipeline.

Black clipping — Sets the black threshold. At zero the content will be displayed as it is encoded. Increasing the black clipping value will increase the portion of the content that is pure black. See the [Low Level Noise Reduction](#) section in Appendix D for details on how to use this control.

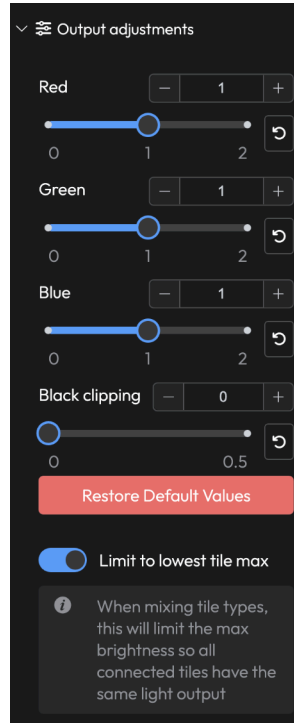

Figure 109: Output Adjustments (Advanced)

Limit to lowest tile max — Helps in situations where mixed tile types form a contiguous display. HELIOS® can restrict the brightness of all tile types to the limit of the tile with lowest max brightness. HELIOS® calculates this in two stages. First stage sets the tile target L to the lowest tile when the **Output > Output adjustment > Limit to lowest tile max** is set. Then, the second stage will further reduce the brightness based on the PQ content max if the **Input pane > EOTF adjustments > Limit brightness to content** is set. The **Image Settings** menu will add the message (**Limited by lowest tile max**) below the nits report when this function is active.

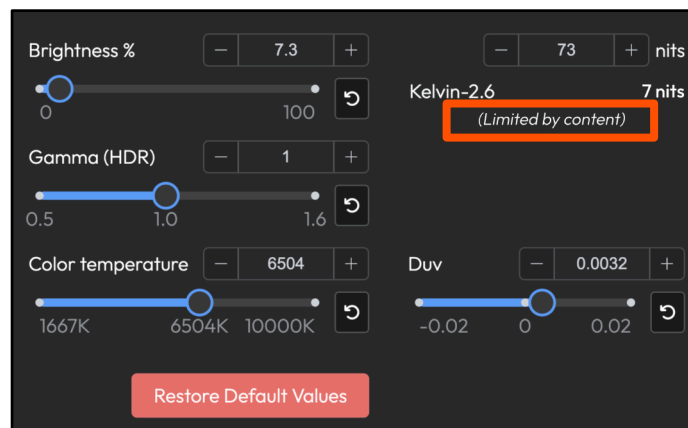

Figure 110: Image Settings message

5.7 GhostFrame® (Advanced)

GhostFrame® is a tool for the motion picture and virtual production industries that takes advantage of the high refresh rates of LED displays to interleave content for cameras with content meant for human vision. LED display panel refresh rates are usually many times higher than the video input frequency. With content usually delivered at 60Hz there is plenty of time for HELIOS® to add several sub-frames (up to the tile limit) to the primary video signal. These sub-frames can be solid colors, still images, and even secondary video feeds to support digital production tools like chroma key or motion tracking. GhostFrame® gives the user control of where in time each sub-frame is placed, and the luminosity of the frames. The patented process of GhostFrame® makes the secondary video feeds, chromakey, and tracking markers all invisible to the human eye and free of any flickering or strobing. Multiple cameras can capture independent images simultaneously as camera shutters are put in phase with different frames.

System bandwidth is unaffected by the use of still images, chroma key frames, and inverse images. These are all handled on the tile's processor. It is the video streams which are bandwidth costly. If a GhostFrame® configuration makes use of two video streams, the overall system bandwidth is halved.

GhostFrame® requires compatible LED tiles. Currently, GhostFrame® is available on ROE Visual and Megapixel display products.

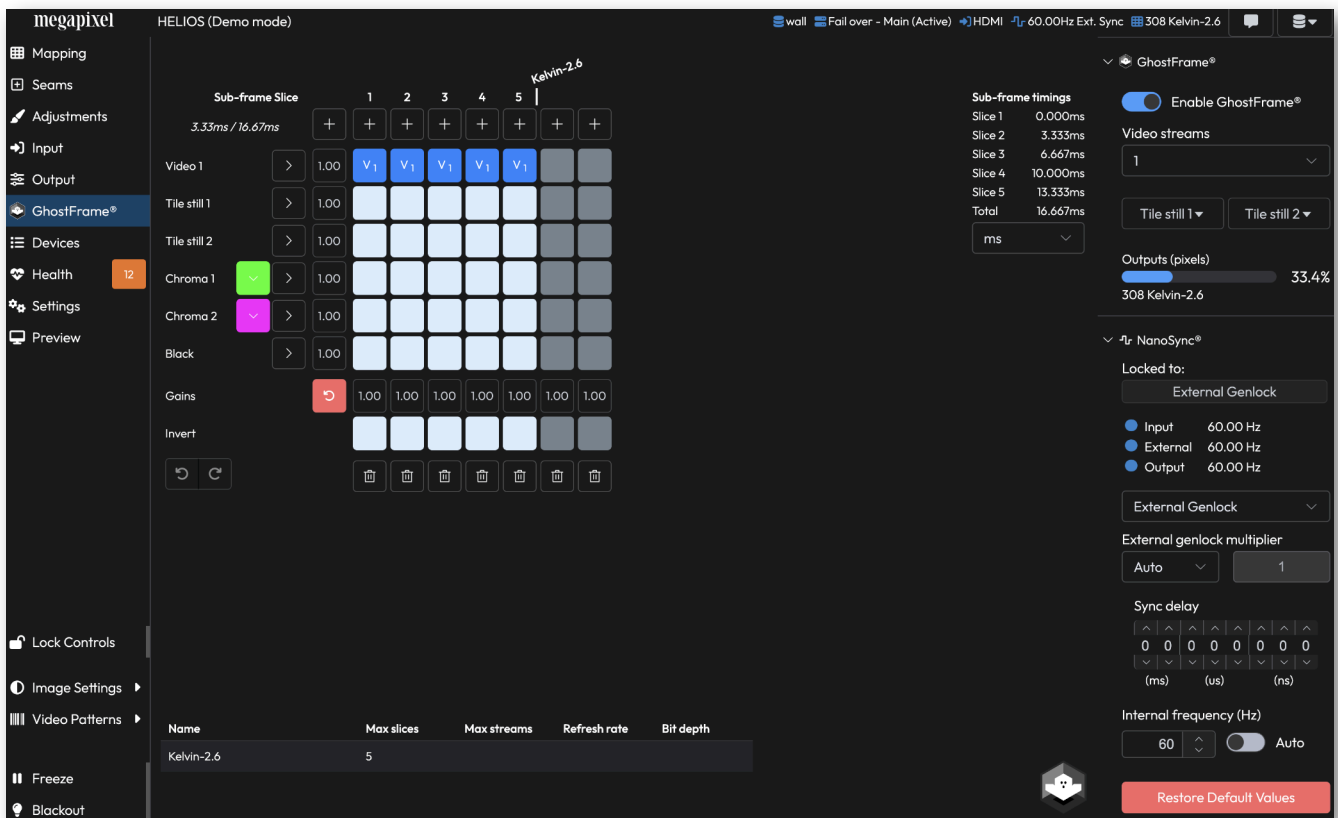

Figure 111: GhostFrame® interface

NOTE: Tile test patterns disable GhostFrame®. Tile test patterns and tile Identify are mutually exclusive to GhostFrame®.

5.7.1 GhostFrame® Licensing

GhostFrame® features require a separate license to activate. There are four (4) different types of licenses.

Four different licenses:

- Camera (default unlicensed)
- Camera+ (expanded Camera features)
- GhostFrame®
- GhostFrame® Demo

The table below describes the available features for each license.

Feature	Camera	Camera+	GhostFrame®	GhostFrame® (Demo)
Chroma	✓	✓	✓	✓
Slices	✓	✓	✓	✓
Still Store	✓	✓	✓	✓
Inversion	X	X	✓	✓ (watermarked)
Multi Stream	2	4	4	4

More information about licenses can be found in the **Settings Pane** > [Licensing](#) section.

Please see <https://ghostframe.com> for additional details.

5.7.2 GhostFrame® Configuration

The GhostFrame® menu is hidden by default, to use GhostFrame®, enable [Advanced Mode](#). Once Advanced Mode is enabled, GhostFrame® will appear in the navigation bar on the left. Select the GhostFrame® pane to reveal the controls. The accordion on the right side of the page contains the main settings for GhostFrame®. The **Enable GhostFrame®** toggle enables/disables GhostFrame® system wide. Once GhostFrame® has been enabled system wide, use the GhostFrame® toggle on the Mapping pane to enable/disable individual tiles or groups of tiles.

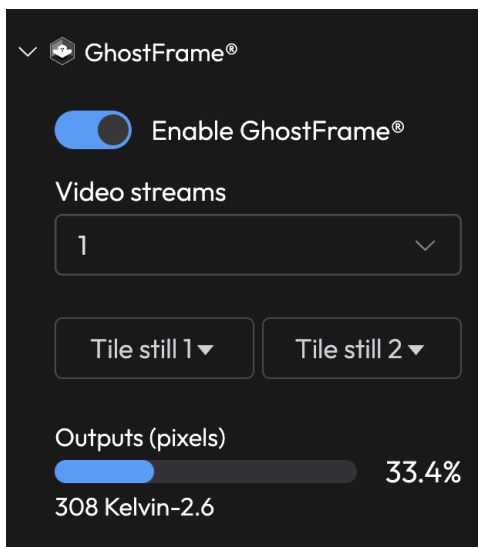

Figure 112: GhostFrame® controls

The Video streams selection box is used to select the number of streams to use (remember multiple streams use more bandwidth!). **Tile still 1** and **Tile still 2** allow the user to capture a single frame of the live input to be used as a video slice. Captured frames are stored in a tile's volatile memory. If tiles are rebooted, any stored stills will be lost. Similarly, each tile will only store its portion of the video frame. If the tile(s) are re-mapped, the still frame needs to be re-stored. The **Sync** section allows the user to enable or disable external sync, add a delay to the sync, and set the internal refresh rate if there are no active inputs.

The Outputs (pixels) reports the current total pixel load as a percent of capacity.

NOTE: When using multiple input sources with GhostFrame® Multi-Source in combination with **Processor Low Latency** the input sources must be stitched horizontally. As an example, configure SDI as a **(2x1)** rather than a **(1x2)**. See the [Input stitching](#) section for more information.

5.7.2 GhostFrame® Configuration

The canvas section of the GhostFrame® controls (center of the web UI) has a grid of square buttons that are used to activate and assign content to slices. The rows are the various slice type options while the columns represent each individual slice as they occur in time from left to right. Higher input frame rates mean fewer available sub-frame slices. Slices should be chosen based on desired features and camera frame alignment requirements. In some cases it may be better to choose fewer slices. Having fewer slices is better in cases where it aligns the number of slices with a multiple of the camera exposure time (consider $2/3$ vs. $3/4$). Interleaving the various image options allow the user to hide slices in the video from the human vision that are at exact timings for camera shutters. While all of this is happening behind the scenes, the performer will see a normal video output on the LED wall.

To be optimal for human vision, GhostFrame® relies on symmetrical timing. If the slices are not temporally balanced, the audience will see an unpleasant pulsing. To illustrate this, assume we have six (6) slices available. If the slices are configured (as in the first example below) to have a Chroma key and inverted Chroma key, the unbalanced frame can give the audience an unpleasant strobing effect. This is due to 3x 'Video 1' slices in a row then 1 Chroma + 1 Chroma Inverted. To correct this, work towards evenly spacing the Chroma keys across the frame (example 2 below). This eliminates the unpleasant pulsing by giving the human vision even intervals to blend the Chroma frames. Consult your GhostFrame® integration partner for configuring and aligning camera capture for use with appropriate GhostFrame® sub-frame slices.

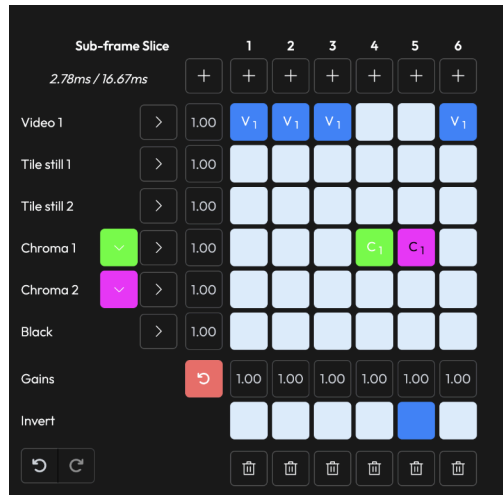

Figure 113: Example 1. GhostFrame® configuration

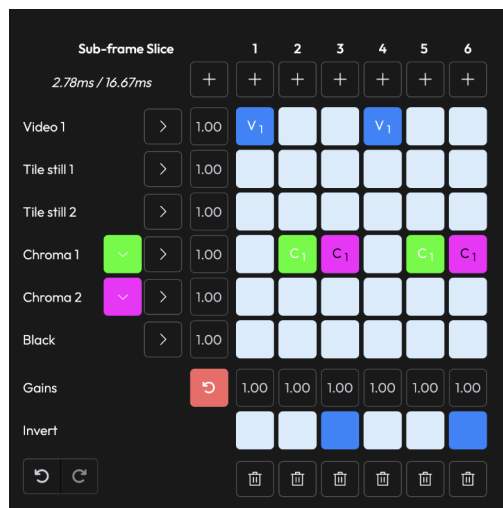

Figure 114: Example 2. GhostFrame® configuration

5.7.3 Sub-frame Slice Gains

Click on a gains button (orange arrow below) to open the Sub-frame gains control window. By default, the gains button reads **1.00**. The gains value is intended to help the user to quickly gauge the net effect of the gains settings. The value represents the cumulative effect that the gains sliders are having on the Sub-frame slice. If the gains sliders are increasing the slice gains, the value will be greater than 1.00. If the controls for the group are decreasing the slice gains, the value will be less than 1.00. Use the red reset arrow button to return all gains to 1.00.

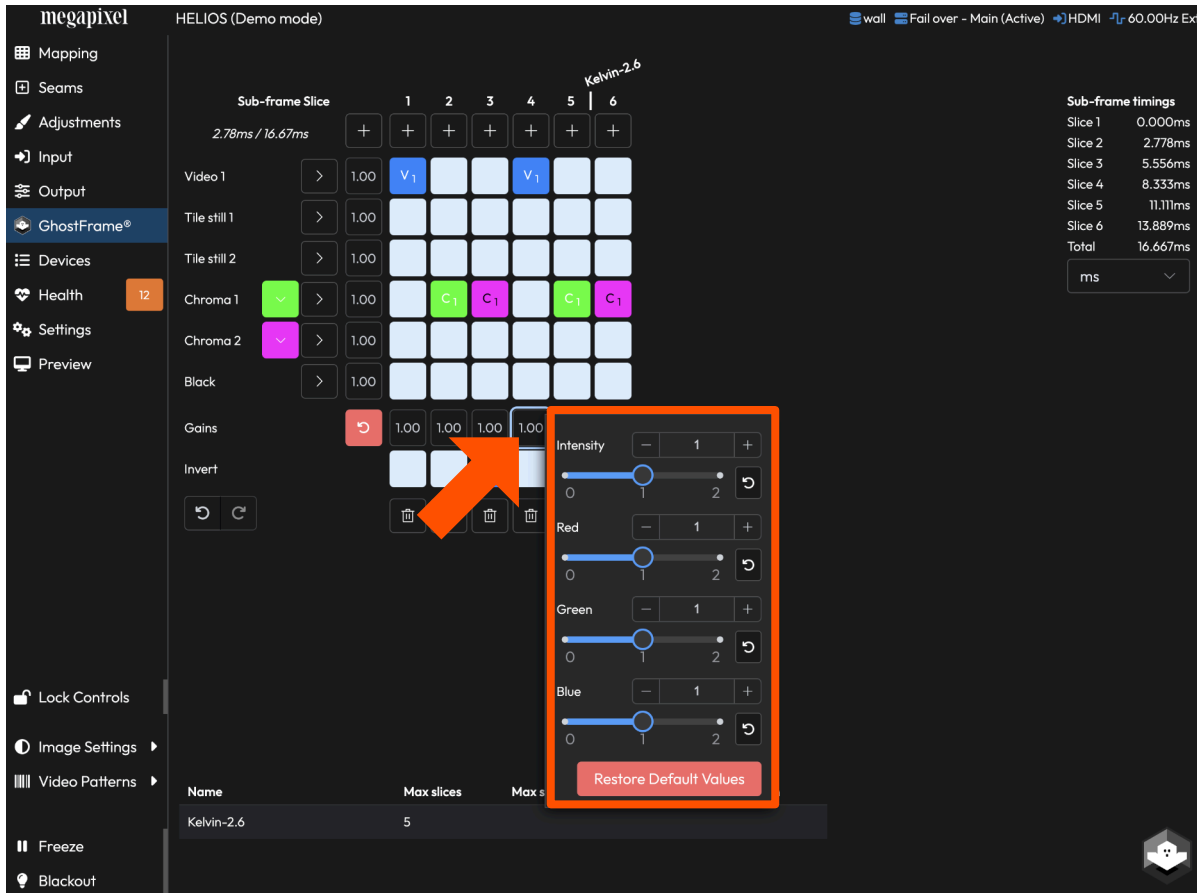

Figure 115: Sub-frame Slice Gains

NOTE: When using groups with **Stacking**, groups replicate across the stack. All HELIOS® processors within the same stack should have the same groups and group settings.

5.7.4 Video Streams

Below is an example of a 4K canvas (gray area below). The selected input is mapped to this canvas. The small orange rectangle represents a mapped tile. When one (1) stream is selected from the **Video streams** dropdown menu, the mapped tile will show content from the V1 orange section for the GhostFrame® V1 sub-frame slices.

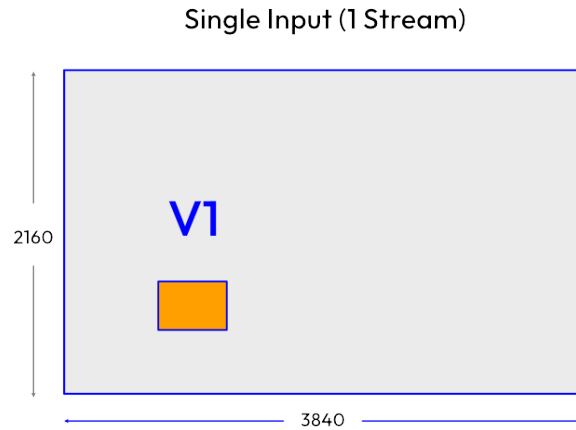

Figure 116: One input, one video stream

If two (2) different streams (V1 and V2) need to be interleaved by GhostFrame®, HELIOS® needs to receive two separate inputs. The selected HELIOS® input needs to be a stitched input (see Section 5.5.1 on [stitched inputs](#)) where HELIOS® combines both inputs into a single canvas. The V1 region supplies the V1 sub-frame slices and the V2 region supplies the V2 sub-frame slices. In the V2 region the mapped tile is shown with a dashed outline as it is the same tile as in the V1 region. The tile receives a V1 and a V2 sub-frame slice according to how the GhostFrame® sub-frames are configured. The point of this technique is to allow HELIOS® to send sub-frame slices from each video stream to the tile at different points in time.

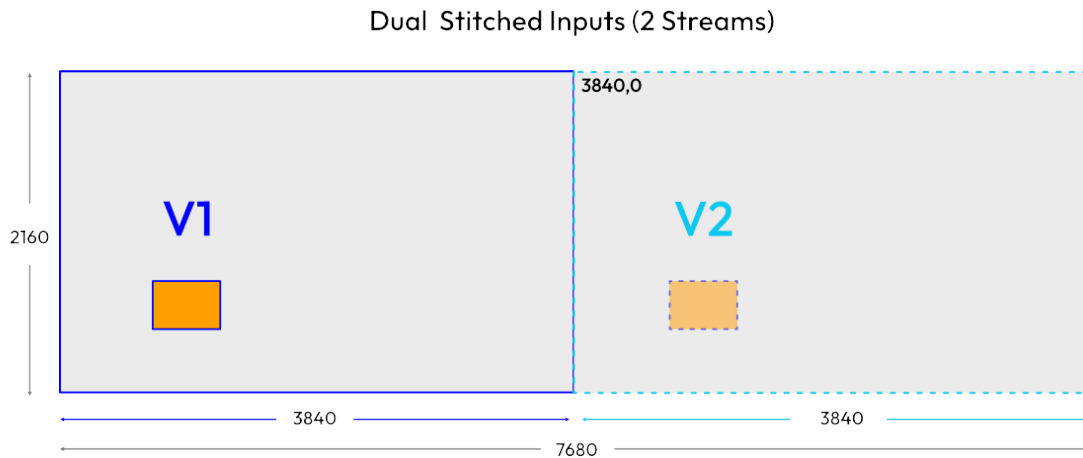

Figure 117: Two inputs, two video streams

5.7.4 Video Streams

In the case of one input and two (2) streams selected from the **Video streams** dropdown menu, HELIOS® offsets the second input horizontally by half of the canvas length. In this way, the first stream contains the full canvas (as before), and now HELIOS® has a second stream containing the right half of the canvas. The mapped tile will show content from the V1 orange section for the GhostFrame® V1 slices and from the V2 area for the V2 slices. The tiles show the video data from the respective underlying canvas region depending on which sub-frame slice should be displayed. This technique is useful when the video arrives at the HELIOS® pre-composited with unique content for each of the active regions (V1 and V2).

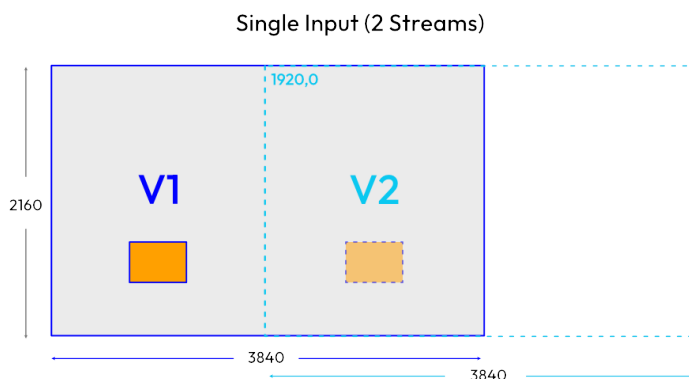

Figure 118: One input, two video streams

When the number of video streams is set to three (3), HELIOS® offsets the second input region by a third of the canvas size, and the third input region by two thirds of the canvas size. So, V1 will show the first section, V2 will show the middle section, and V3 the right section.

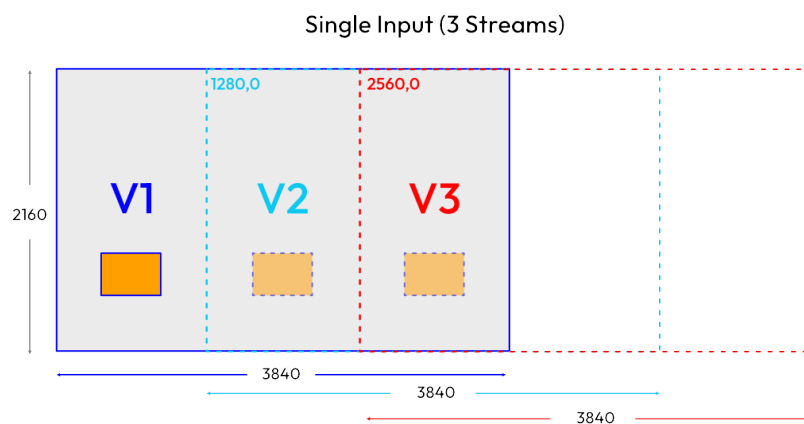

Figure 119: One input, three video streams

In the case of four (4) video streams selected, HELIOS® divides the canvas into quarters and offsets respectively. Notice that the GhostFrame® video streams have nothing to do with the input. It's all relative to the canvas.

The point of this technique is that it allows a user to show different regions of the same feed on the tiles at different points in time. With this system, the user sends a single input to HELIOS®. GhostFrame® is used to split the feed back out again temporally. The end result is a direct mapping from input to offset video stream output.

NOTE: Tiles can opt out of GhostFrame® and be set to display any of the video streams. See [GhostFrame® Opt Out](#) in the **Mapping> Tile configuration** section for more information.

5.7.5 Camera (Advanced)

Without a GhostFrame® license, HELIOS® will display the **Camera** pane. The **Camera** pane is a limited subset of the full GhostFrame® tools. As such, all of the rules and methodology discussed in the previous section of GhostFrame® apply to **Camera**. Camera+ licenses are available for those looking for additional streams. The [GhostFrame® licensing](#) section earlier in this user guide has a table of GhostFrame® licenses and the features available with each. The **Camera** pane is most often used for aligning camera shutters to colored slices.

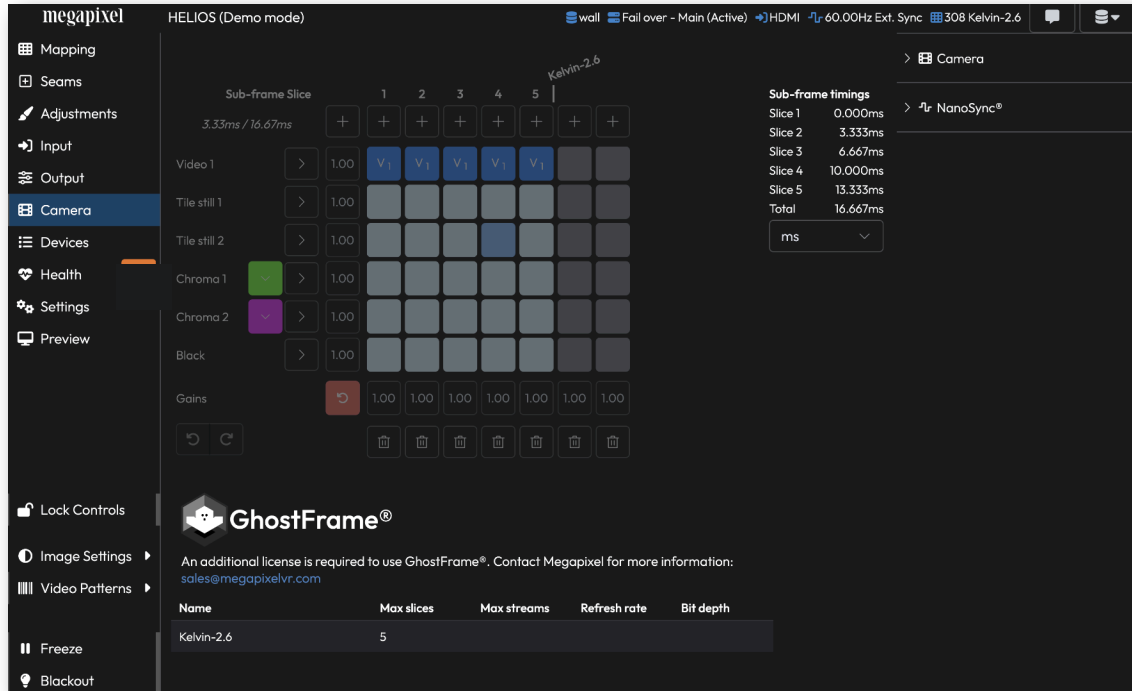

Figure 120: Camera interface

NOTE: Tile test patterns disable **Camera**. Tile test patterns and tile Identify are mutually exclusive to **Camera**.

5.8 Devices Pane

The **Devices** pane is a dynamic list of all connected system devices. The information is split into two tabs: a **Processing** tab and a **Display Devices** tab. This pane is usually the first place a system technician will check to assess the status of a system.

5.8.1 Processing Tab

The tab is divided into sections starting at the top with information for the HELIOS® **Processor(s)** followed by **Network Switches**.

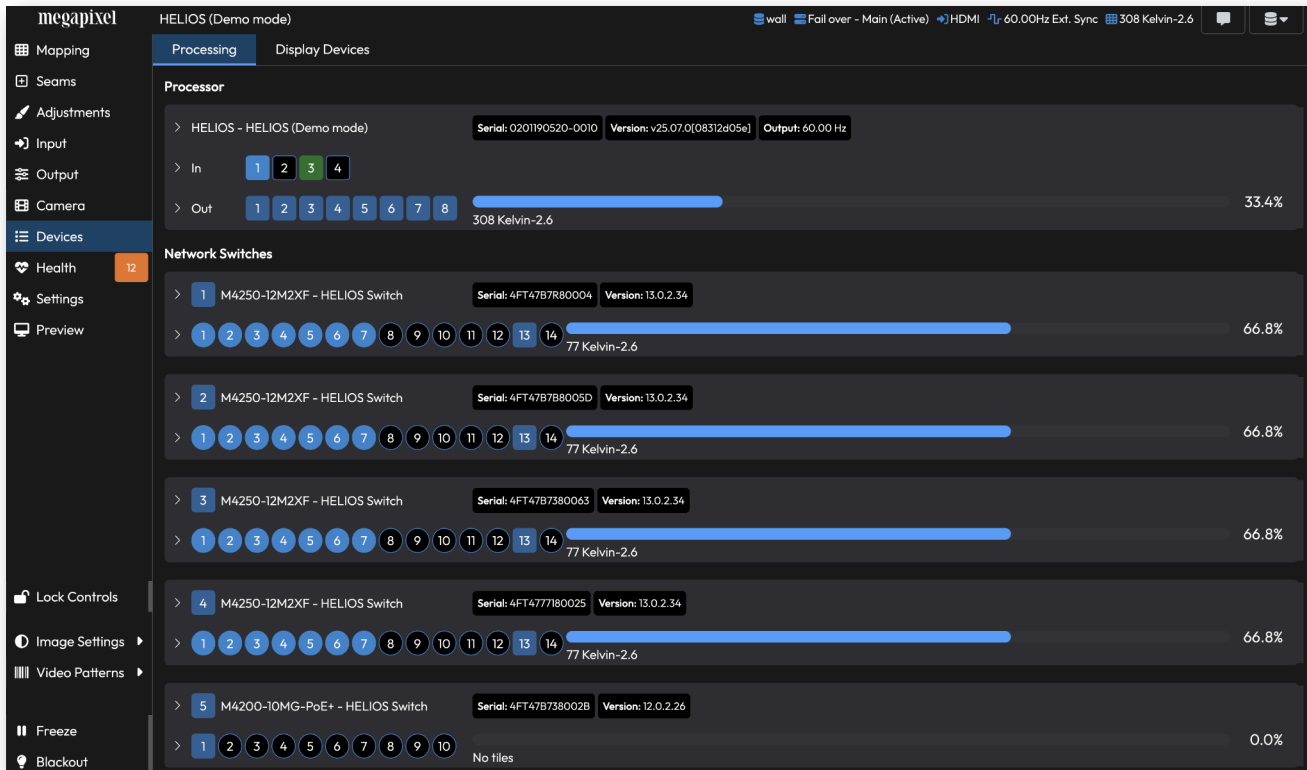

Figure 121: Devices pane

5.8.2 Processor

The **Processor** section of the **Devices** pane displays the full list of tracked parameters for the HELIOS® under the first disclosure chevron (arrow below). Use the description field to name the processor as desired. This is the same as changing the name in **Settings > Processor Settings > Description**.

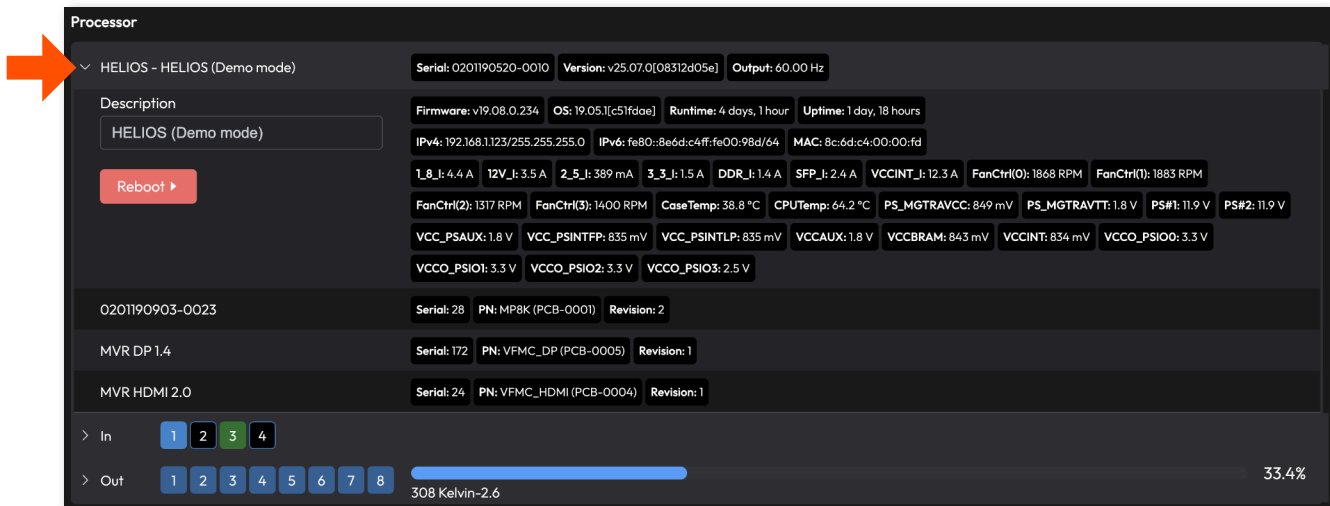

Figure 122: Devices Pane — HELIOS® Parameters

Under the second disclosure chevron, the **In** section of the HELIOS® displays details about the input SFP+ units. The square icon with the number on it is the input icon. When this icon is a blue square with white text (orange arrow in the example below) the unit is receiving video through the SFP+. When the HELIOS® recognizes the SFP+ but there is no video, the icon will be a dark green (input 3 in the example below). In both blue and dark green modes there will be parameters displayed and a label regarding the type of SFP+ that is in the slot. A black with light blue outline icon (ports 2 and 4 in the example below) indicates that the HELIOS® unit does not recognize any SFP+ in the slot.



Figure 123: Devices Pane — HELIOS® Inputs

5.8.2 Processor

Under the third disclosure chevron, the **Out** section shows the status of the outputs and a percentage of utilization of the entire HELIOS®. Expand the output section of the HELIOS® to see details about the outputs. Each port shows a progress style bar showing the port's percent utilization. Underneath the bar is the quantity and type of tiles connected.

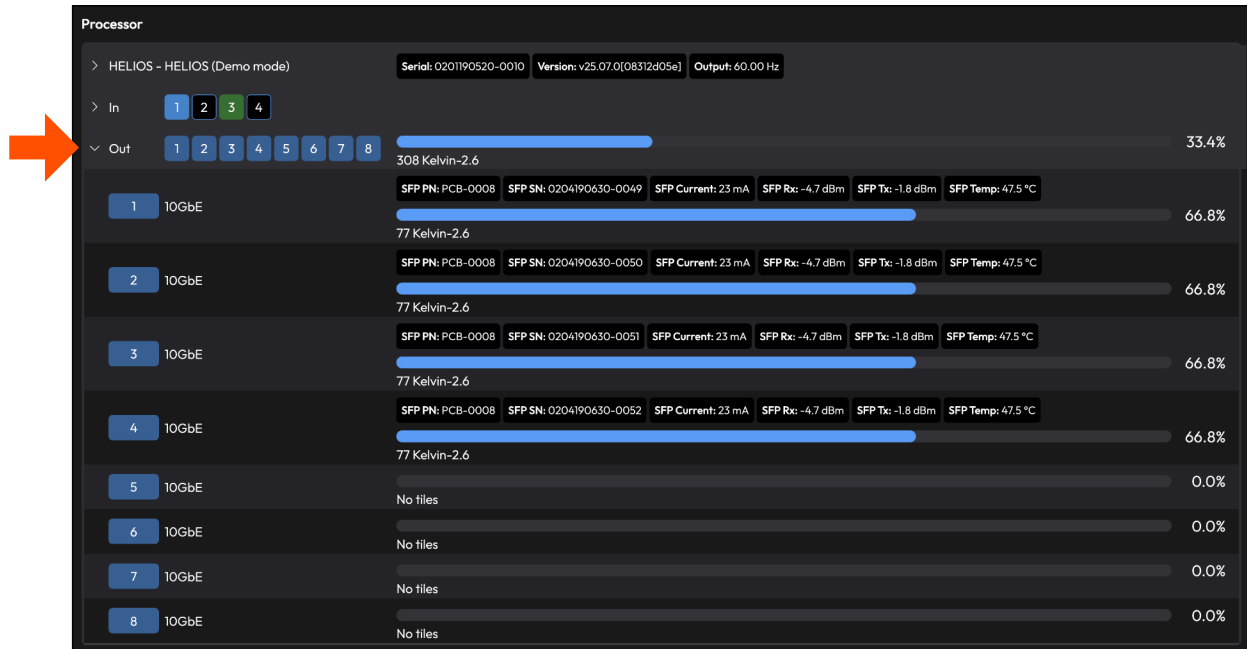

Figure 124: Devices pane – HELIOS® Outputs

The shape and the color of the port indicators relate to the port connection. See the table below for the detail on what each color means. Standard HELIOS® outputs will always be square since all Standard HELIOS® output SFP+ units are 10Gb. The port on the switch connecting to HELIOS® will be square (as it's connected to a processor). Similarly, the upstream port on the first tile in a chain is also square (as it links back to a processor).

Indicator Color	Meaning
Orange	Unsupported SFP
Red	< 1GbE link speed
Blue	1 GbE
Lavender	2.5 GbE
Dark Blue	10 GbE
Dark Green	SFP with no link
Inverted Blue	SFP with link

5.8.3 Network Switches

The first disclosure chevron reveals details for the network switches. Enter a description for the switch if this is helpful for managing the system. This assigned description is persisted within the switch. A remote reboot switch button can also be found here.

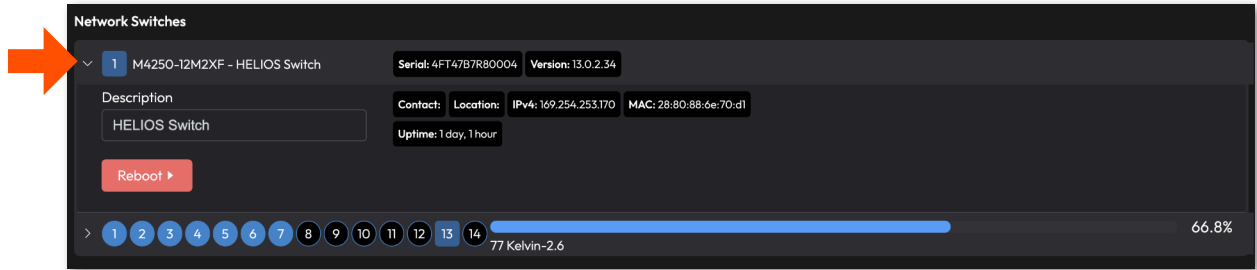
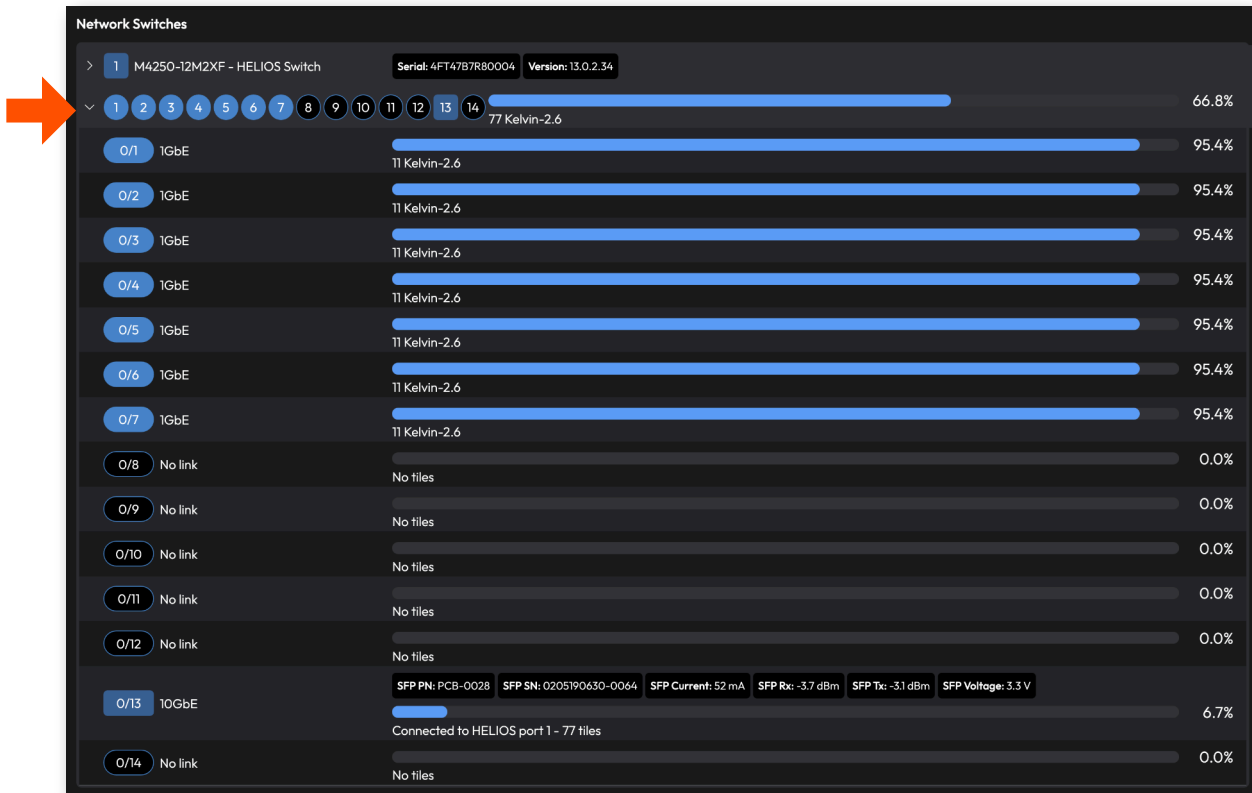

Figure 125: Devices pane — Network Switch Parameters

The second disclosure chevron reveals details about the ports. Switch port IDs use slot/port nomenclature. On standard size switches, all ports are considered slot 0; port IDs are numbered 0/1–0/14 as shown in the example below. When HELIOS® is managing a redundant system, additional information appears on this pane about the redundant data routes. (See [Appendix F](#) — Data Redundancy for more information.)

To the right of each port ID is a percent utilization bar with connected tile quantity and type below.

Figure 126: Devices pane — Network Switch details



5.8.4 Display Devices Tab

The **Devices > Display Devices** pane contains a list of connected tiles with detailed parameters and status for each. The list can be sorted by any of the column headers. The **Alerts** column (orange arrow below) can be especially useful to identify all devices with active alerts.

Name	Connected	HELIOS Port	Switch Port	String Pos	Serial #	Version	MAC Address	Link	Alerts	Hub	Identify
Kelvin-2.6	Main	3	7	8	Tile's Serial	a19.08.0.0	0e:ba:00:00:00:00	1 2	1	6009 RPM	<input type="checkbox"/>
Kelvin-2.6	Main	3	7	9	Tile's Serial	a19.08.0.0	0e:ba:00:00:00:02	1 2	1	5951 RPM	<input type="checkbox"/>
Kelvin-2.6	Main	3	7	5	Tile's Serial	a19.08.0.0	0e:ba:00:00:00:04	1 2	1	5894 RPM	<input type="checkbox"/>
Kelvin-2.6	Main	3	7	1	Tile's Serial	a19.08.0.0	0e:ba:00:00:00:06	1 2	1	5974 RPM	<input type="checkbox"/>
Kelvin-2.6	Main	3	7	2	Tile's Serial	a19.08.0.0	0e:ba:00:00:00:08	1 2	1	5562 RPM	<input type="checkbox"/>
Kelvin-2.6	Main	3	7	4	Tile's Serial	a19.08.0.0	0e:ba:00:00:00:0a	1 2	1	5614 RPM	<input type="checkbox"/>
Kelvin-2.6	Main	3	7	11	Tile's Serial	a19.08.0.0	0e:ba:00:00:00:01	1 2	1	6044 RPM	<input type="checkbox"/>
Kelvin-2.6	Main	3	7	10	Tile's Serial	a19.08.0.0	0e:ba:00:00:00:05	1 2	1	5240 RPM	<input type="checkbox"/>
Kelvin-2.6	Main	3	7	3	Tile's Serial	a19.08.0.0	0e:ba:00:00:00:09	1 2	1	5897 RPM	<input type="checkbox"/>
Kelvin-2.6	Main	3	7	7	Tile's Serial	a19.08.0.0	0e:ba:00:00:00:03	1 2	1	5628 RPM	<input type="checkbox"/>
Kelvin-2.6	Main	3	7	6	Tile's Serial	a19.08.0.0	0e:ba:00:00:00:07	1 2	1	5920 RPM	<input type="checkbox"/>
Kelvin-2.6	Main	4	7	11	Tile's Serial	a19.08.0.0	02:ef:13:00:00:01	1 2	1	5508 RPM	<input type="checkbox"/>
Kelvin-2.6	Main	4	7	7	Tile's Serial	a19.08.0.0	02:ef:13:00:00:03	1 2	1	5868 RPM	<input type="checkbox"/>
Kelvin-2.6	Main	4	7	10	Tile's Serial	a19.08.0.0	02:ef:13:00:00:05	1 2	1	6012 RPM	<input type="checkbox"/>
Kelvin-2.6	Main	4	7	6	Tile's Serial	a19.08.0.0	02:ef:13:00:00:07	1 2	1	5692 RPM	<input type="checkbox"/>
Kelvin-2.6	Main	4	7	3	Tile's Serial	a19.08.0.0	02:ef:13:00:00:09	1 2	1	5272 RPM	<input type="checkbox"/>
Kelvin-2.6	Main	4	6	11	Tile's Serial	a19.08.0.0	02:ef:14:00:00:01	1 2	1	5982 RPM	<input type="checkbox"/>

Figure 127: Devices pane — Display Devices

5.9 Health Pane

The health pane contains comprehensive network status information about all parts of a connected HELIOS® system. This pane contains three tabs: **Alerts**, **Heat map**, and **Reports**.

5.9.1 Alerts

To help prioritize alerts, the HELIOS® color codes alert badges based on the severity of the condition.

The screenshot shows the 'megapixel HELIOS Demo' interface. The 'Health' tab is selected, showing 15 alerts. The 'Alerts' sub-tab is active, displaying a table of alerts. A callout box titled 'Alert Colors' points to the colored alert counts in the table.

Count	Severity	Brief	Description	Since
2	Error	Over temp	Exceeds normal operating temperature	1.1 days
4	Warning	Calibration data	LDM calibration data in EEPROM is not present or is invalid	1.0 days
4	Warning	Invalid Sys Config	One or more internal device(s) are not programmed correctly	1.0 days
1	Warning	SFP incompatible mode	SFP is not compatible with current operating mode (see debug settings)	1.1 days
4	Notice	Invalid LED batch ID	An LDM has an unsupported/invalid LED batch ID	1.0 days

Alert Colors

- Notice: Light Green
- Warning: Yellow
- Error: Orange
- Critical: Red

Figure 128: Alert Color Codes

The **Alerts** tab provides a list of devices that need attention. Use the disclosure chevron next to the colored alert count (orange rectangle below) to reveal details about the location of each alert within the system.

The screenshot shows a close-up of the 'Alerts' tab table. An orange arrow points to a disclosure chevron (a small downward-pointing triangle) next to the 'Count' column for the 'Over temp' alert. This chevron is highlighted with an orange rectangle.

Count	Severity	Brief	Description	Since
2	Error	Over temp	Exceeds normal operating temperature	1.1 days

Below the table, there is a section for device details:

Name	Port	Switch	String	Serial #	MAC Address
Eclipse 1.5 P3	1	6	1	18	8c:6d:c4:01:0c:2e
Eclipse 1.5 P3	1	6	5	<none>	8c:6d:c4:00:fb:i4

Figure 129: Alerts tab

5.9.2 Temperature Heat Map

The heat map tab displays thermal information for tiles in the system. Temperatures are indicated in a rainbow palette that shows thermal differences in 5° increments.

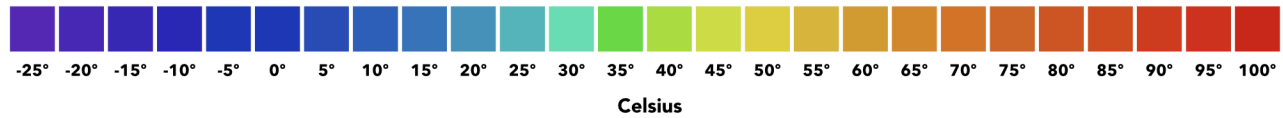

Figure 130: Color to temperature

In the example below, one tile has raised an alert with a CPU at 89.5°C. Use this view to quickly identify any temperature anomalies in the system. In addition to the tile sensor data, the hover tooltip shows the text of tile notes (see Section [5.4.8 Tile Notes](#)) if a note has been created. With multiple tiles selected, HELIOS® will display the minimum, the average and the maximum values for the selected tiles. The heat map is not just useful for recognizing hot panels. It is good practice to warm LED panels up prior to being used at full brightness. Use the heat map to monitor progress and to confirm when panels are ready for use. Select a tile or several tiles to have HELIOS® display their current temperature on the right side of the pane.

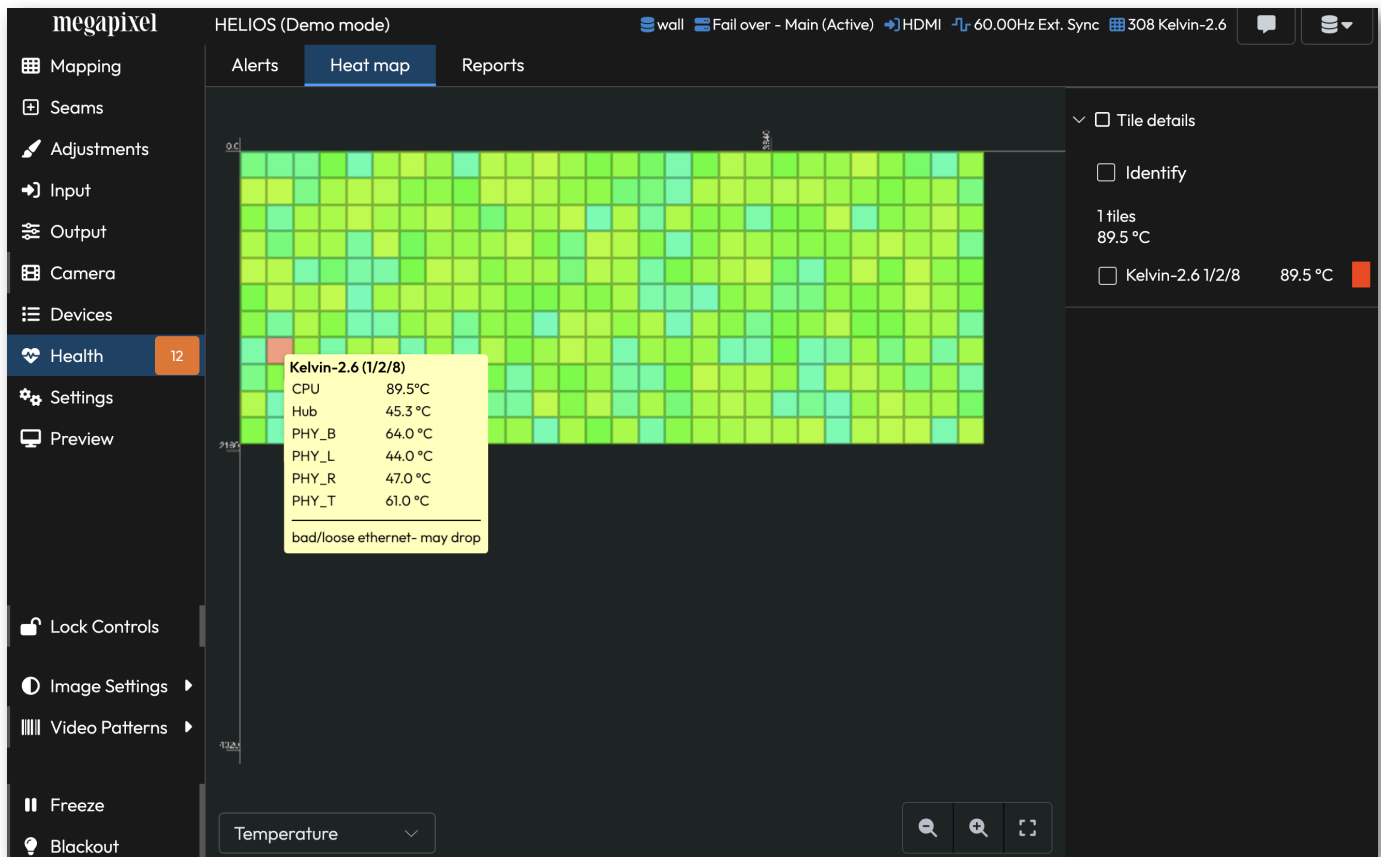

Figure 131: Heat map

5.9.3 Humidity Heat Map

The rH percentage each tile is reporting is indicated in a rainbow palette that shows differences in four (4) percent increments.

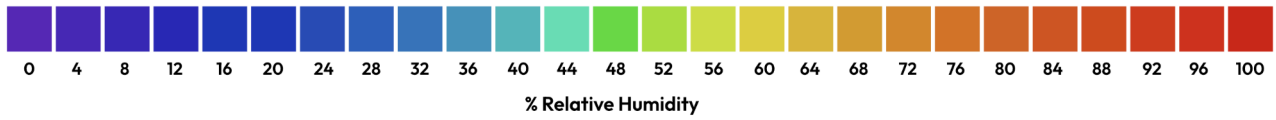

Figure 132: Color to percent relative humidity (rH)

When tile firmware supports it, the heat map tab displays a dropdown menu option in the bottom left corner to select **Humidity** (arrow below).

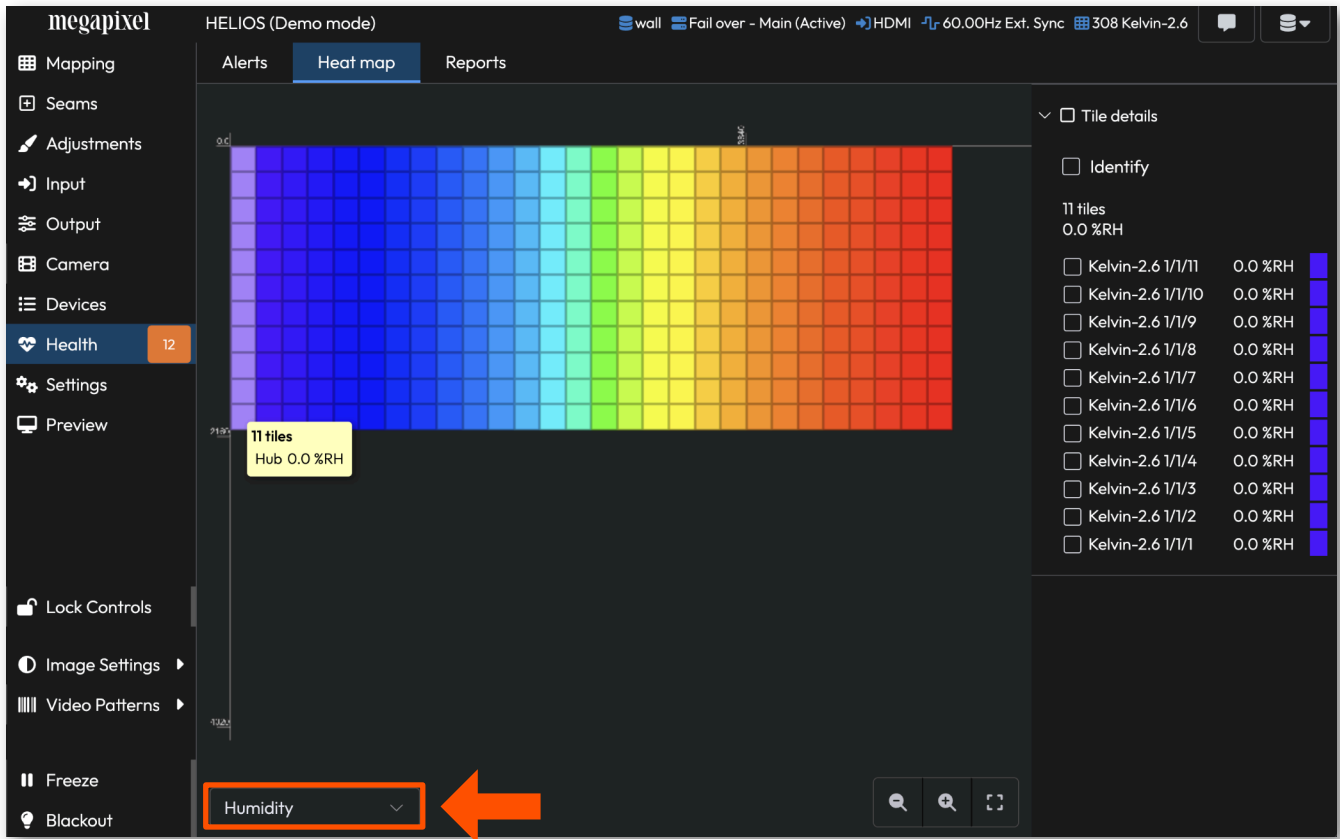

Figure 133: Relative humidity map

5.9.4 Network Errors Heat Map

A rainbow palette is used to visualize the number of network errors reported by a tile.



Figure 134: Color to number of network errors

The **Heat map** tab displays a dropdown menu option in the bottom left corner, select **Network errors** (shown below) to display the heat map. When tiles are selected in the map, their details will be listed on the right.

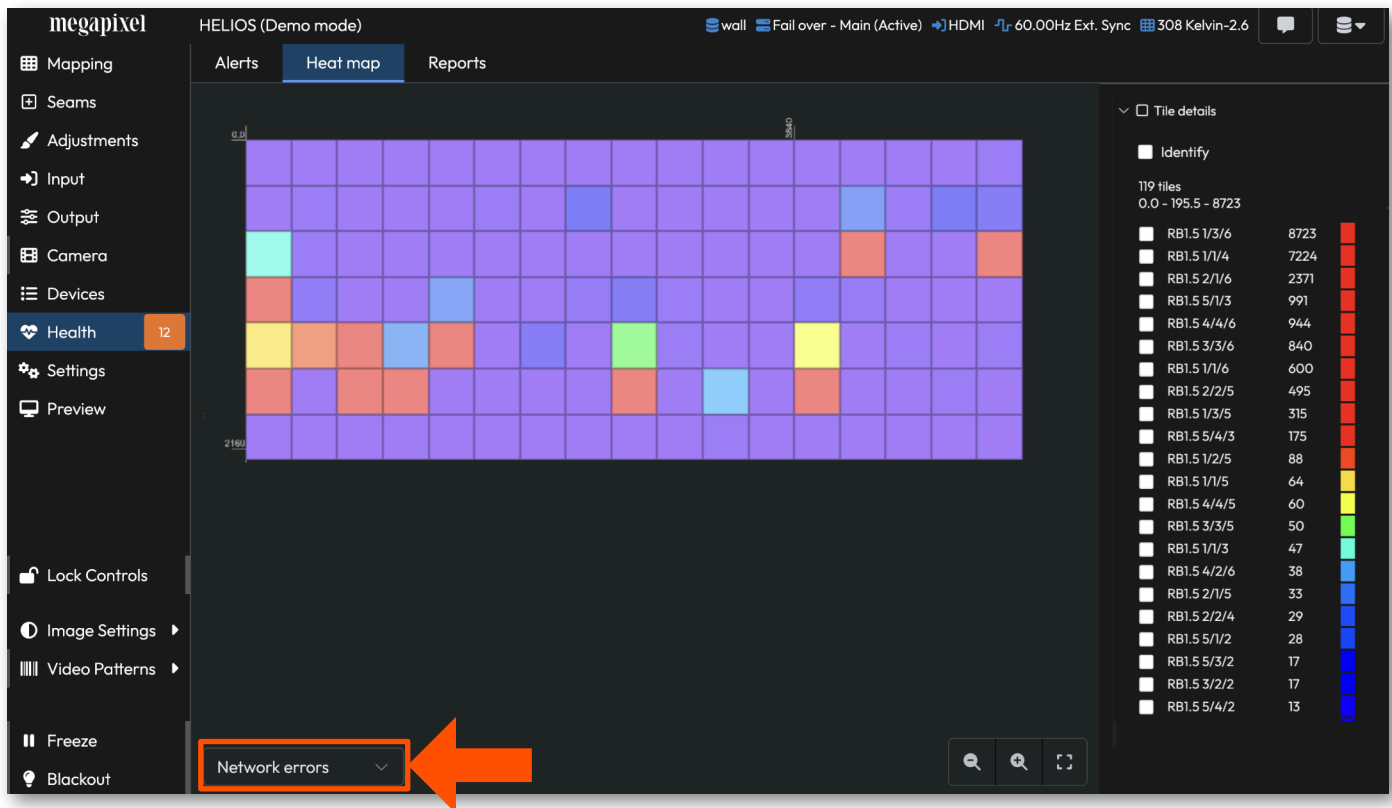

Figure 135: Network errors heat map

5.9.5 Reports

The reports tab fetches data from tiles and switches to provide reports in the UI or a downloaded report (csv file format) for several data points in the system. These functions query tiles and switches for the selected information when a report type is selected from the dropdown menu. In the example below, **Pixel error detection** was selected.

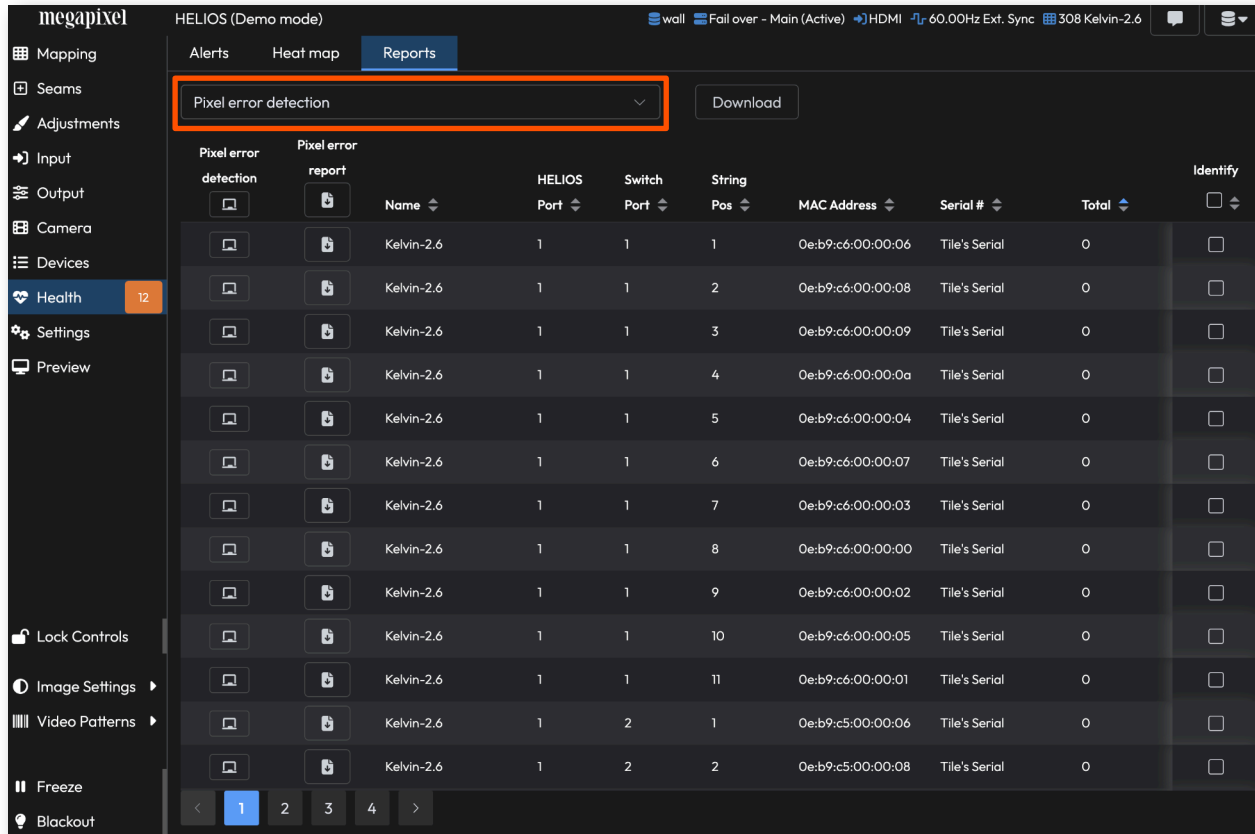

Figure 136: Reports tab

Function	Description
Alerts	Devices that need attention.
Device serial numbers	All SNs, useful for inventory tracking.
Device uptime/runtime	All devices and how long they have been operational. Useful for finding units that reboot more often than others.
Device versions	Active device software and firmware versions.
Fiber sensors	Fiber hardware health.
Pixel error detection	Tiles with pixel errors.
Switch interface counters	Switch specific issue counters. These diagnostic counters can help diagnose system issues.
Tile calibration	Tile LDM serial numbers.
Tile counters	Tile connectivity health. These various diagnostic counters can help with troubleshooting tile health and cable issues.
Tile Sensors	All sensor information from connected tiles.
Tile topology	Connection information regarding each tile. The topology numerical code corresponds to how the tile is connected to the system (HELIOS® Port / Switch Port / String position). As an example 3/1/1 means, 3rd HELIOS® port / 1st Switch port / 1st tile in the string.
Tile notes	Notes from connected tiles.

5.9.6 Troubleshooting with Counters Reports

The **Switch interface counters** and the **Tile counters** are key reports to use during system setup and maintenance. These two report types can identify cable errors, hardware errors, mixed speed links and video issues.

Switch interface counters — track two metrics **Discards** and **Errors** for both the inbound and outbound traffic.

Discards — Can be caused by internal switch errors such as load balancing issues.

Errors — Can be caused by hardware issues or faulty cables.

Name	HELIOS Port	Switch Port	Link	Devices	inDiscards	inErrors	outDiscards	outErrors
M4250-12M2XF - HELIOS Switch	1	0/1	1GbE	T1 Kelvin-2.6				
M4250-12M2XF - HELIOS Switch	1	0/2	1GbE	T1 Kelvin-2.6				
M4250-12M2XF - HELIOS Switch	1	0/3	1GbE	T1 Kelvin-2.6				
M4250-12M2XF - HELIOS Switch	1	0/4	1GbE	T1 Kelvin-2.6				

Figure 137: Switch interface counters

Tile counters — track several tile metrics; the ones to watch for system troubleshooting are:

Cable/HW errors — Can be caused by faulty cables or other aberrant hardware.

Video errors — these occur when there are issues with the video frames processed by the tile. Can be caused by upstream video/sync problems and network errors.

Packet discards — a sign of mixed speed links. This can happen when inadvertently mixing 1G and 2.5G tiles in the same chain. Ensure all tiles on a switch link are of the same link speed. Do not daisy chain different speed tiles on the same link!

Link drops — counts the number of times the link speed has gone to zero (0). This counter is triggered by completely losing the link. This might not be visible on other counters that catch other types of glitches.

Name	HELIOS Port	Switch Port	String Pos	MAC Address	Serial #	Uptime	Reboots	Missed responses	Cable/HW errors	Video errors	Packet discards	Link drops
Ventana XR08 Liquid Black	1	1	1	8c:6d:c4:03:28:a0	030E230420-0367	22.0 hours	1199	3	1	1	0	0
Ruby 1.9 V6.0	1	2	1	8c:6d:c4:02:40:4d	RB19BM000643	22.0 hours	1722	3	0	2	0	0
Ruby 2.3	1	3	1	8c:6d:c4:01:47:9a	RB230M004422	22.0 hours	201	3	0	0	0	0
Black Pearl 2.8 V2.1	1	4	1	8c:6d:c4:01:df:cc	BP280M096190	22.0 hours	2348	3	0	0	0	0
Black Pearl 2.8 V2.1	1	4	2	8c:6d:c4:01:c5:df	BP280M097562	22.0 hours	1435	3	0	5	0	0
RMI.5E	1	5	1	8c:6d:c4:03:3d:8a	AOTO-RMI.5E-0004	22.0 hours	771	3	0	0	0	0

Figure 138: Tile counters

5.10 Settings Pane

With [Advanced Mode](#) enabled, the **Settings** Pane contains eight (8) tabs: **Processor Settings**, **Security**, **Still Store**, **Scheduler**, **Saved Configurations**, **Update Center**, **Shortcuts**, and **About**. The following pages describe the functionality found on these tabs.

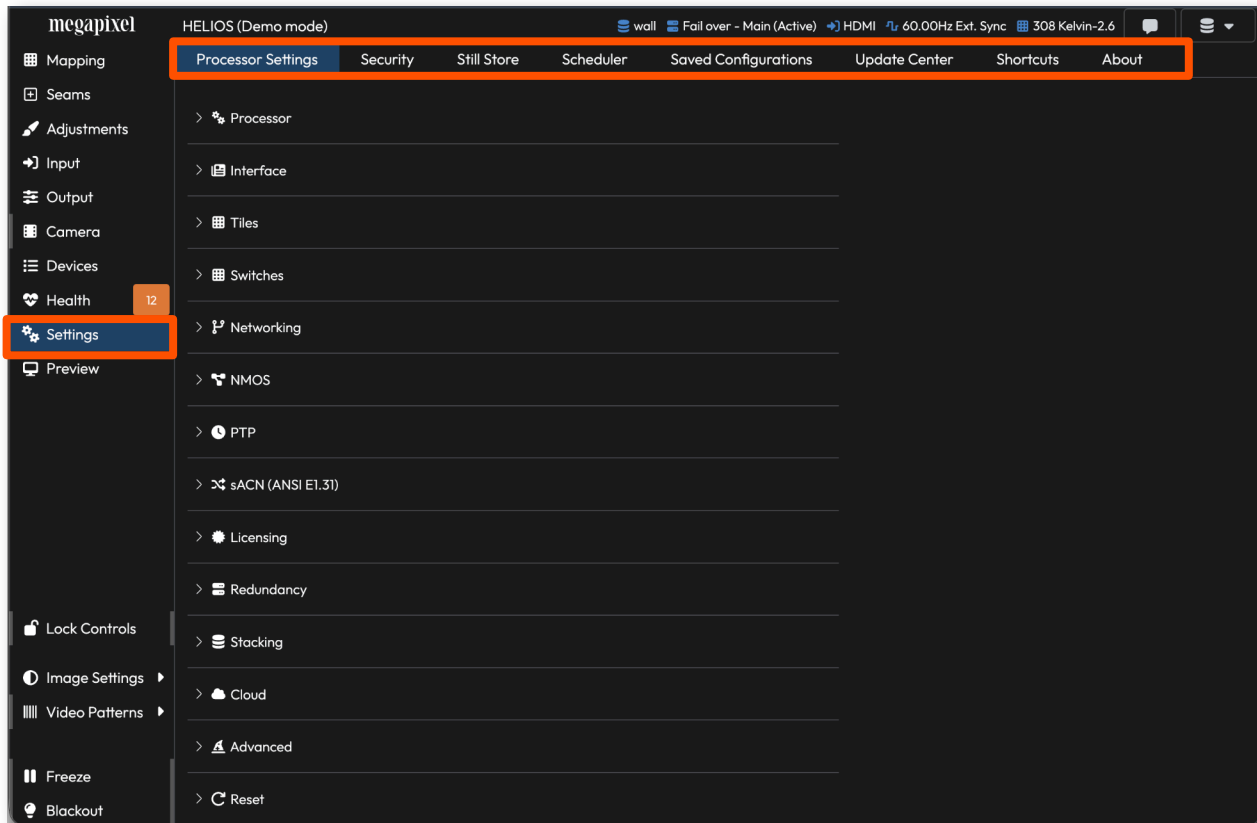

Figure 139: Processor Settings

5.10.1 Processor Settings

Processor

Description — Enter the name of the processor. Changes are updated live.

Operating Mode —

Standard license — HELIOS® can use either 10GbE fiber SFP+ modules or 1GbE copper SFP modules.

Junior license — HELIOS® can only use 1GbE copper SFP modules.

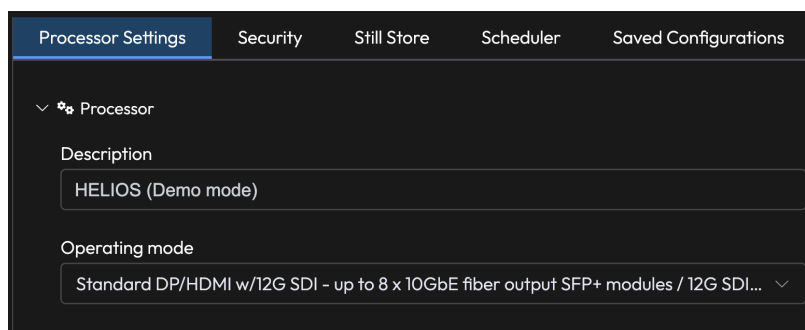

Figure 140: Description and Operating mode selection

5.10.1 Processor Settings

Changing the operating mode will trigger a pop-up warning asking for confirmation. Select **Switch Mode** to change and reconfigure the system for the new module type.

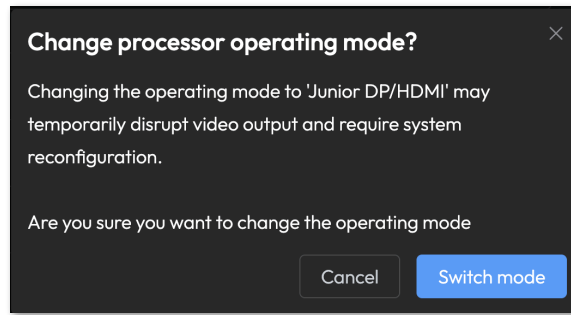

Figure 141: Switch mode confirmation

Interface — Select a color theme (**Dark** or **Light**) and/or select a language for the user interface.

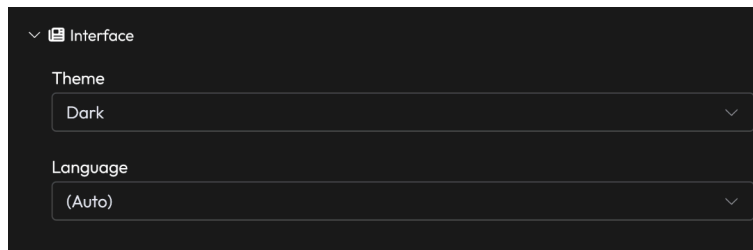

Figure 142: Theme selection

Tiles

- **Show Rear Indicators toggle** — See [Tile details](#) for more information.
- **Identify behavior** — Select how tiles should behave when the tile Identify feature is enabled. Techs usually set this to **Rear indicator only** once a system is show-ready.
- **Fan control** — When supported by tile firmware, select from available tile fan modes.
- **Low power mode** — When supported by tile firmware, set how tiles behave when global blackout is enabled.



Figure 143: Tile settings

5.10.1 Processor Settings

Switches

- **Fan control** — The switch provides several fan operating modes to balance acoustic noise and cooling performance. In most installations, **Quiet** mode is recommended for normal ambient temperatures allowing the switch to automatically reduce fan speed when thermal conditions permit. **Cool** mode is intended for higher-load or warmer environments and prioritizes lower internal temperatures over noise. When available, **Fan Off** mode can be used only in low-power, well-ventilated situations; if temperature exceeds safe thresholds, the switch will automatically ramp the fans back on to protect the hardware.
- **Switch port configuration** — Each network port supports auto-negotiation and can also be manually configured for a fixed 1 GbE link where required. Auto-negotiation is recommended for most AV-over-IP endpoints so that the switch and connected device can automatically select a compatible link mode. Forcing 1 GbE can be useful when troubleshooting devices that behave unpredictably during auto-negotiation, or when a stable, locked-down 1 GbE link is required by system design or test procedures. Unlike switches that allow forcing 100 Mb or 10 Mb, this control is not a general workaround for damaged or out-of-spec cabling; if a cable cannot reliably support a 1 GbE link, the connection may still flap or fail and the cable should be inspected and corrected rather than relying on port-speed settings.

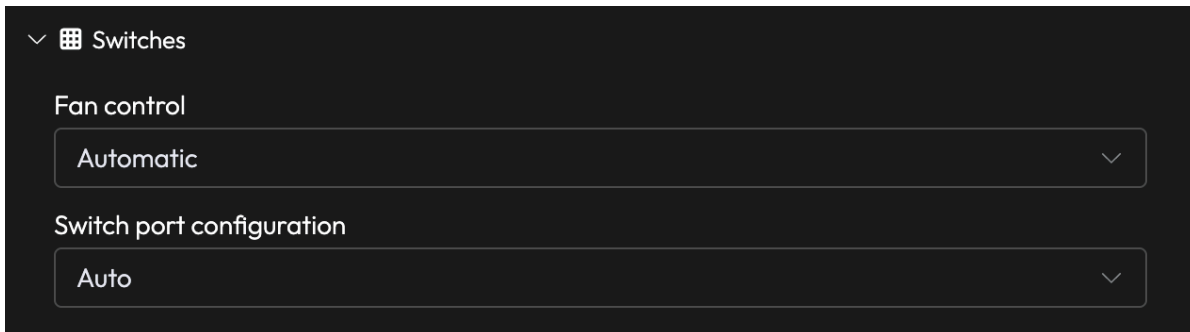

Figure 144: Switch settings

NOTE: This feature is only supported on the MSM4214X switch. Switches require SW FW 13.0.5.16+. This update is available through the HELIOS® **Update Center**.

5.10.1 Processor Settings

Networking — Toggle network discovery protocols (DNS-SD + SSDP) on or off, and configure the IP settings of the HELIOS®. See [Section 4.2](#) IP Addressing for more details.

Networking

Allow iframing (disables iframe prohibiting HTTP headers)

Network discoverable (DNS-SD + SSDP)

IP Configuration

Control

DHCP/AUTOIP Addressing

IPv4 Address: 192.168.1.123 Subnet Mask: 255.255.255.0

Router: 192.168.1.1

DNS: 192.168.1.1

NTP server(s): pool.ntp.org HELIOS' time: 2025-08-08 16:26:37

DHCP Client ID: [Empty field]

IPv6 Address: fe80::8e6d:c4ff:fe00:98d IPv6 Prefix: 64

MAC Address: 8c:6d:c4:00:00:fd

Apply

HTTPS

Redirect to HTTPS

megapixelvr.com
Issued by: megapixelvr.com
Expires: Wed Jan 27 9999 14:14:13 GMT-0600 (Central Standard Time)
Type: RSA-2048

Upload cert + key

Figure 145: Networking

5.10.1 Processor Settings

Networking (Advanced) — With Advanced Mode enabled, the **Networking** accordion will display a **Redirect to HTTPS toggle** at the bottom of the section. Toggle ON to redirect all browser **http://** requests to **https://**.

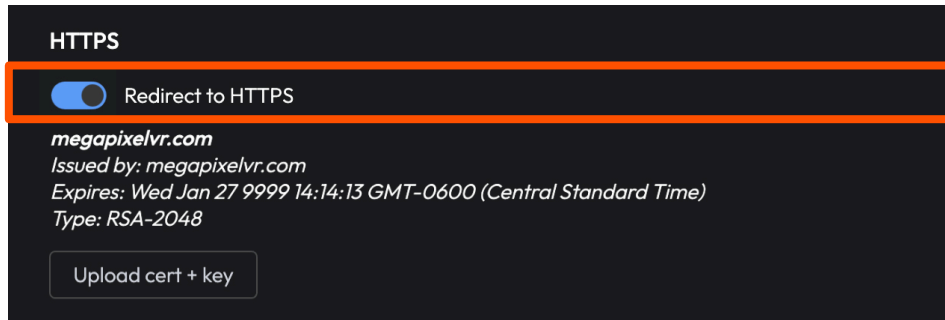

Figure 146: Redirect to HTTPS toggle

HTTPS Certificates

By default HELIOS® uses a self-signed certificate. For security-critical deployments, HELIOS® also supports customer-provided certificates obtained from an SSL certificate authority.

The advantages of a custom signed certificate over the default self-signed certificate:

- The connection is properly validated and secure
- The certificate warning shown when using self-signed certificates is removed

To upload a custom certificate:

1. Obtain a signed certificate and private key from an SSL certificate authority
2. Press Upload cert + key and upload the certificate and private key in PEM format
3. All future HTTPS sessions will be secured with the uploaded certificate

To regenerate the self-signed certificate, use the regenerate button in the same window.

NOTE: An HTTPS connection is required when using gamepad controllers to perform Seam correction. Please see the [Seams](#) section for more details.

5.10.1 Processor Settings

Recommended network settings for an HTTPS deployment:

1. Disable Network discoverable
2. Redirect to HTTPS
3. Upload cert + key

See [Appendix I](#) for full technical details on HTTPS configuration.

The screenshot displays the 'Networking' settings page. At the top, there are two toggle switches: 'Allow iframing (disables iframe prohibiting HTTP headers)' and 'Network discoverable (DNS-SD + SSDP)'. The 'Network discoverable' toggle is highlighted with a red box and labeled with a '1'. Below this is the 'IP Configuration' section, which includes fields for IPv4 Address (192.168.1.123), Subnet Mask (255.255.255.0), Router (192.168.1.1), DNS (192.168.1.1), NTP server(s) (pool.ntp.org), HELIOS' time (2025-08-08 16:26:37), DHCP Client ID, IPv6 Address (fe80::8e6d:c4ff:fe00:98d), IPv6 Prefix (64), and MAC Address (8c:6d:c4:00:00:fd). An 'Apply' button is located at the bottom of this section. Below the IP Configuration section is the 'HTTPS' section, which is highlighted with a red box and labeled with a '2'. It contains a 'Redirect to HTTPS' toggle switch, which is turned on. Below the toggle, there is a certificate preview for 'megapixelvr.com' with details: 'Issued by: megapixelvr.com', 'Expires: Wed Jan 27 9999 14:14:13 GMT-0600 (Central Standard Time)', and 'Type: RSA-2048'. An 'Upload cert + key' button is located at the bottom of the HTTPS section, which is labeled with a '3'.

Figure 147: Network settings for HELIOS® HTTPS

5.10.1 Processor Settings

With the proper ST 2110 SFPs installed and with HELIOS® set to ST 2110 operating mode, the **Processor > Settings** list will display NMOS settings.

NMOS — Enable / disable NMOS with the toggle. All the other fields are read only. See [Appendix G](#) for more information on ST 2110 systems.

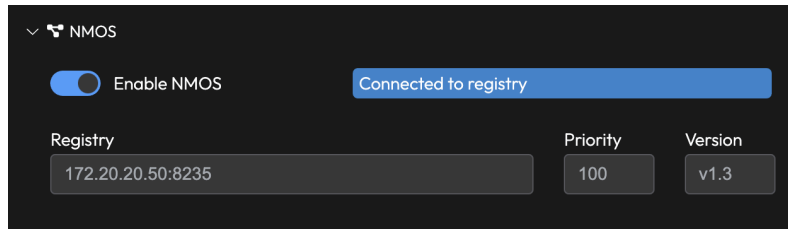

Figure 148: NMOS Processor Settings

PTP — Enable / disable PTP with the toggle. The domain value serves as an identifier for PTP messages and devices. Devices use the domain value to filter and process only the PTP messages relevant to their domain. Configure the domain to match the sending PTP device. PTP supports up to 256 domains (0-255). The default domain is 127.

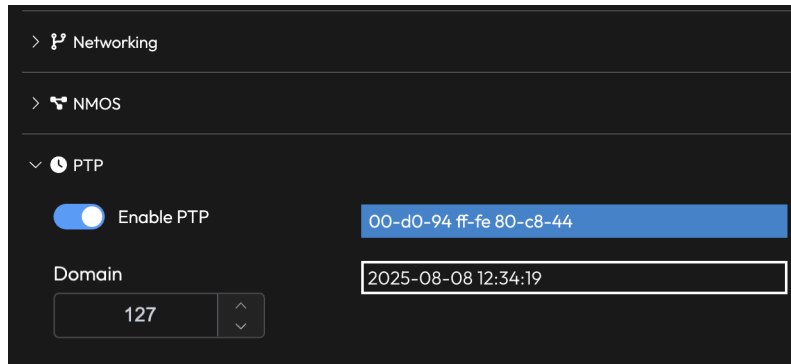

Figure 149: PTP Processor Settings

5.10.1 Processor Settings

sACN (ANSI E1.31) — Use the sACN or E1.31 protocols to remote control HELIOS®. When sACN is valid and active, a green bar with the sACN source name will be shown above the channels.

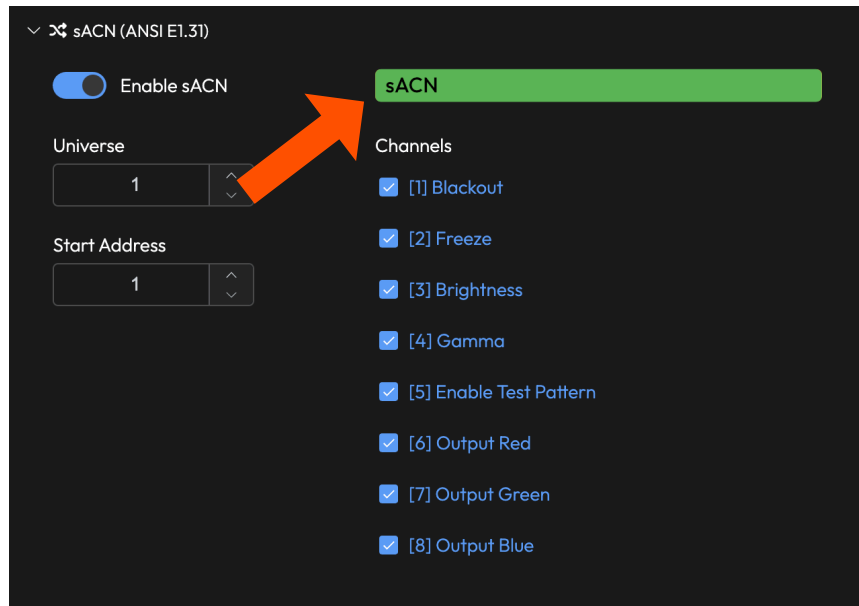

Figure 150: sACN enabled

The GUI controls are locked out for sACN controlled functions. Function names will be highlighted in **bright turquoise** throughout the interface.



Figure 151: Locked out functions

5.10.1 Processor Settings

sACN (ANSI E1.31)

When [tile groups](#) are created, groups are by default assigned channels **10 - 15**. The channel assignments will show up below the primary sACN control channels.

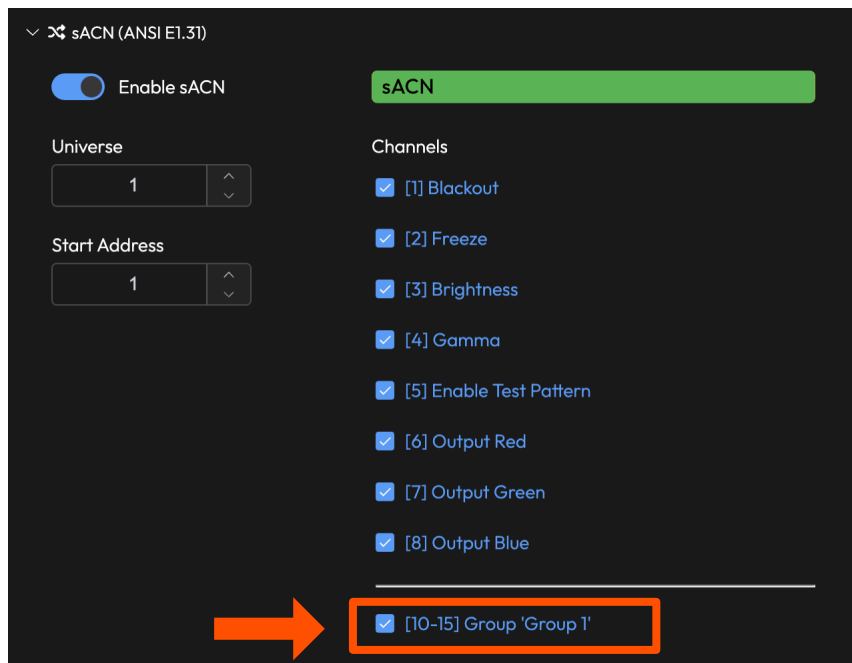

Figure 152: Tile group channel assignment

Use the **Tile Group Settings > Start Address** to set the **Start Address** of tile groups.

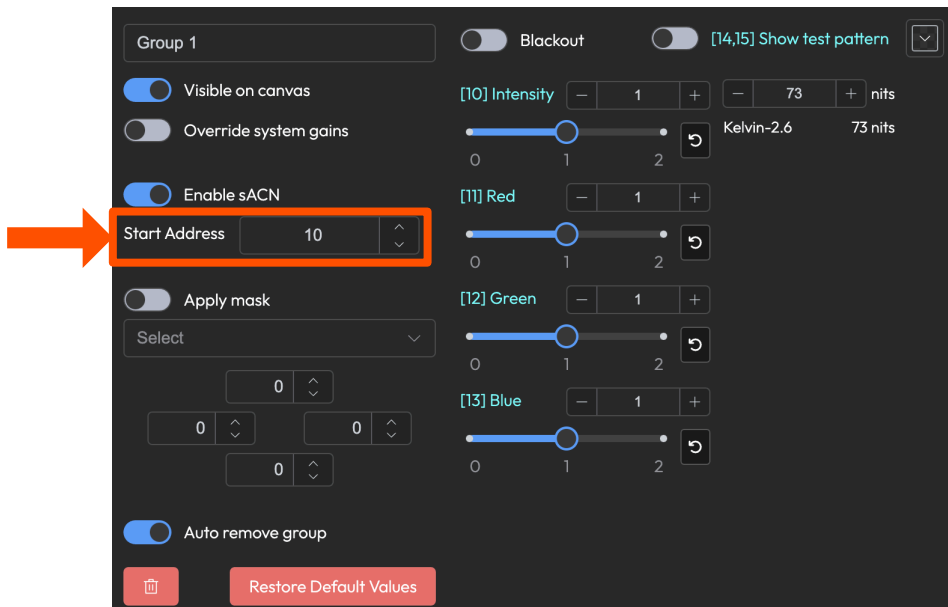

Figure 153: Tile group Start Address

5.10.1 Processor Settings

sACN (ANSI E1.31)

The table below describes HELIOS® behavior for inbound sACN.

Main Channels	Function	Value
1	Blackout	0 = Normal operation 128 and above = Blackout
2	Freeze	0 = Normal operation 128 and above = Freeze
3	Brightness	(0-255) Slider position 0 - 100% mapped to sACN
4	Gamma	(0-255) Slider position 1.0 - 4.0 (SDR) mapped to sACN (Gamma 2.4 = 119)
5	Test Pattern	0 = Normal operation 1 - 255 = Show test pattern
6	Output Red	(0-200) Slider position 0.0 - 2.0 mapped to sACN
7	Output Green	(0-200) Slider position 0.0 - 2.0 mapped to sACN
8	Output Blue	(0-200) Slider position 0.0 - 2.0 mapped to sACN
Tile Group Channels		
10*	Intensity	(0-200) Slider position 0.0 - 2.0 mapped to sACN
11	Red gains	(0-200) Slider position 0.0 - 2.0 mapped to sACN
12	Green gains	(0-200) Slider position 0.0 - 2.0 mapped to sACN
13	Blue gains	(0-200) Slider position 0.0 - 2.0 mapped to sACN
14	Pattern toggle	(0-255) 128 and above = ON
15	Pattern alpha	(0-255) 0 = full transparent 255 = opaque

*10=default start address

5.10.1 Processor Settings

Licensing

HELIOS® units require a license to operate. Two main license types are available — HELIOS® Standard and HELIOS® Jr. — with additional specialized licenses for GhostFrame® and HDCP.

Activating a license online:

- Press the Activate license button in the UI
- Enter the activation key
- HELIOS® will communicate with the Megapixel licensing server to generate and install the license automatically

Activating a license offline:

- Press the Download Support Archive button on the **About** page (Section 5.17)
- Send the archive to your Megapixel representative
- Once the license file has been returned, press **Upload license** and navigate to the file on the local machine to load it into HELIOS®

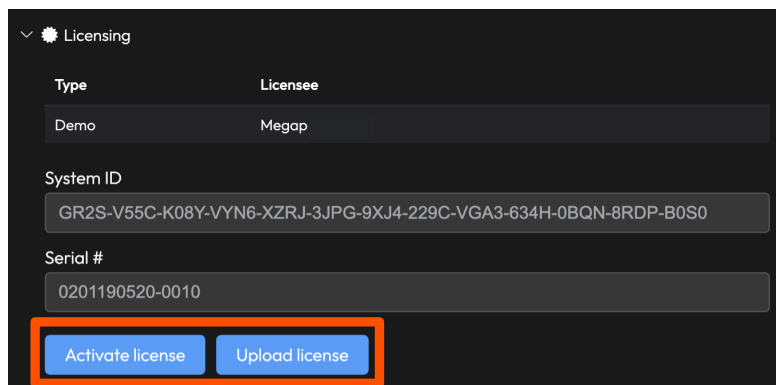

Figure 154: Licensing

Redundancy (Advanced) — Please see the [Data Redundancy](#) in Appendix F for details.

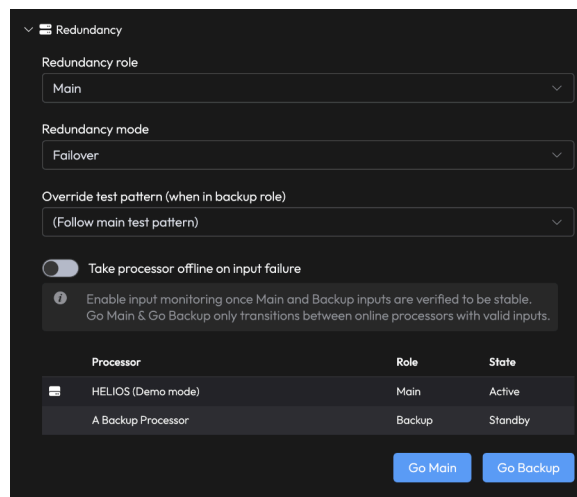

Figure 155: Redundancy settings

5.10.1 Processor Settings

Stacking (Advanced) — Stacking allows individual processors that operate sections of a large screen to synchronize functions such as blackout, freeze, and color adjustments. In most cases, stacking should be used with redundancy in the HELIOS® system. Enter a Stack name to have the processor join a stack. In the example below, the current HELIOS® has been assigned to **wall**. Below the Processor stack name field, a table shows that HELIOS® is aware of another processor in the system named **A Backup Processor**, assigned to a stack named **wall**.

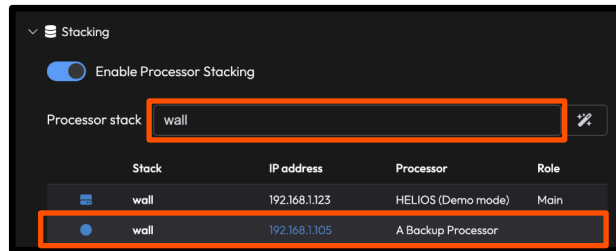

Figure 156: Stacking settings

Cloud — Enable analytics to be sent to the development team.

Advanced — When advanced features are enabled, several features that have not been selected for general release will show up throughout the user interface.

Reset to factory settings — Returns a HELIOS® unit to factory defaults. This will wipe all HELIOS® stored settings, while leaving the tile settings. Mapping position will revert to 0,0 with no rotation, no groups, but LDM seams will be re-retrieved from the tile.



Figure 157: Reset to factory defaults

Data stored on tiles:

- LDM Configuration
- LDM Seams (user + factory)
- Notes
- Tile Still Store image (volatile memory — cleared on reboot)

Data stored on HELIOS®*:

- Mapping position
- Rotation
- Group assignment
- Other settings are stored within HELIOS® by tile MAC. On connecting a tile to HELIOS®, the settings are pushed to the tile (cal bypass, LDM gains, tile low latency, etc).

*Stored on HELIOS® by tile position / topology and then falling back on MAC address,

If there is even a remote possibility the system might need to be returned to its pre-reset state, create a saved configuration and download it prior to factory resetting the HELIOS®. See [How to move configuration files](#) for details. Alternatively, a less permanent solution may be to load the HELIOS® default factory saved configuration. See the [factory default saved configuration](#) section for more details.

5.11 Security (Advanced) User Authentication

In the **Settings > Security** tab, HELIOS® can be configured to require a user and password for access. HELIOS® has selectable complexity requirements. Ensure the selected complexity requirement matches the security requirements of the installation. Press the **Create User** button to open a form window to enter the user info. It is good practice to create an Admin account first. Once security is enabled, standard users will only see a list of logged-in users.

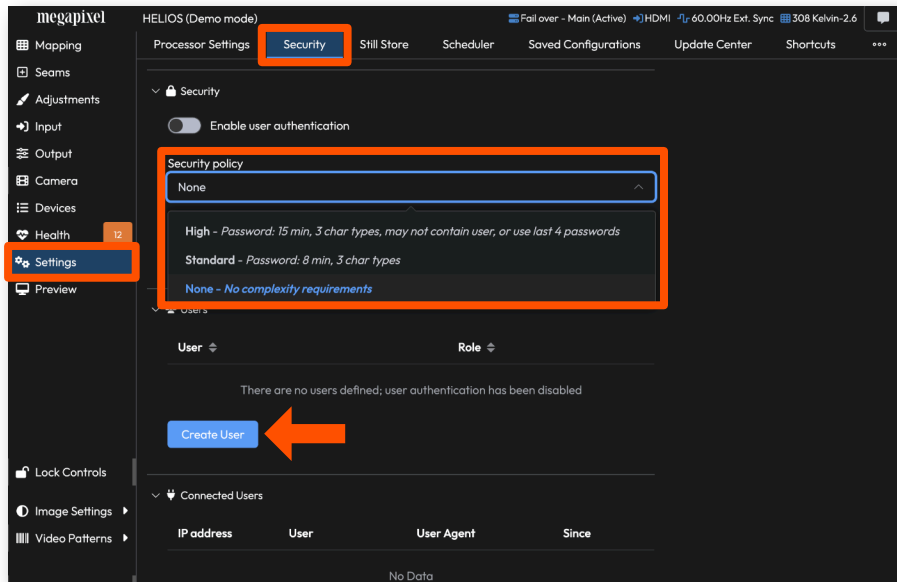

Figure 158: Security pane

Complete the fields. When selecting a role (Admin or User), keep in mind that Admin privileges are required to create and edit users. Press **Add User** to create the account.

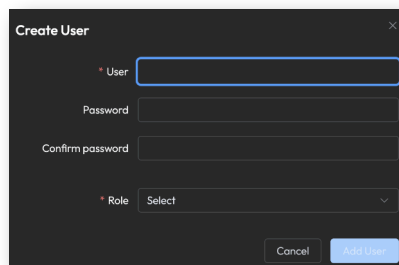

Figure 159: Create user

Google maintains a list of compromised passwords. If a user is created with a simple password such as 'test' or 'password', expect a Chrome warning.

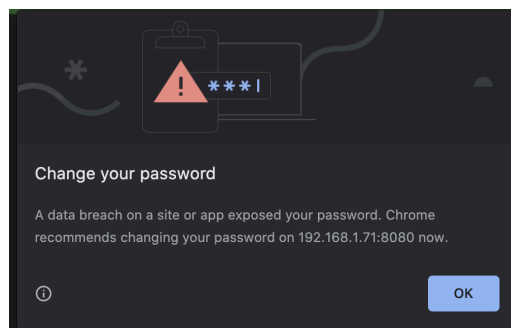

Figure 160: Password warning

5.11 Security (Advanced) User Authentication

Use the **Enable user authentication** toggle to turn on security. **Be certain of the user and password prior to enabling security!** If credentials are lost, only a factory default reset will unlock the HELIOS®. See the [Unknown User / Password](#) in Appendix B.

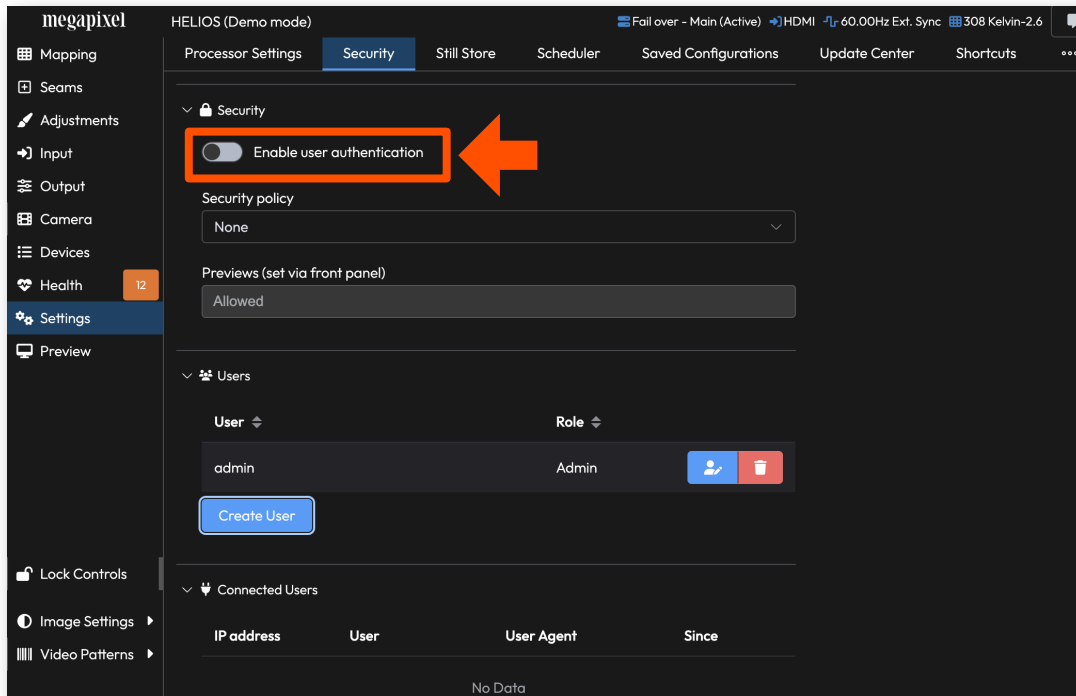

Figure 161: Enable User Authentication

Authentication is required immediately after enabling.

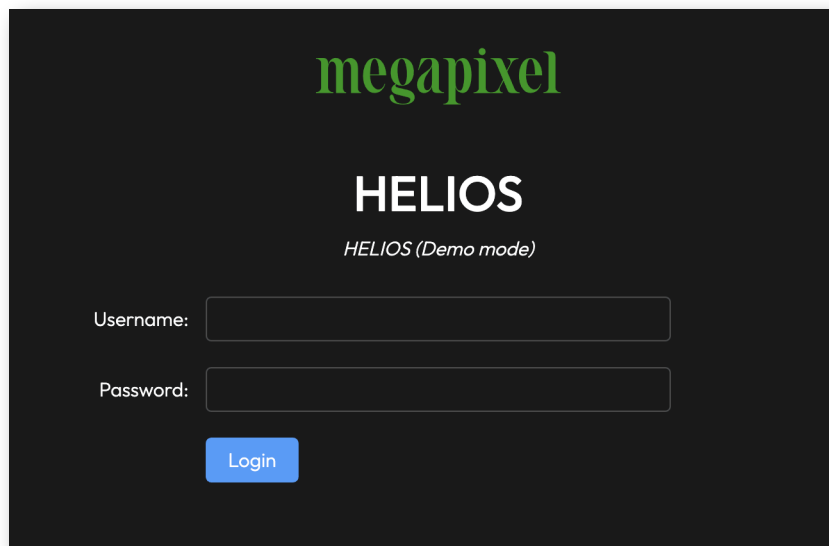

Figure 162: Authentication required

5.11 Security (Advanced) User Authentication

When logged in, the user will appear at the top right.

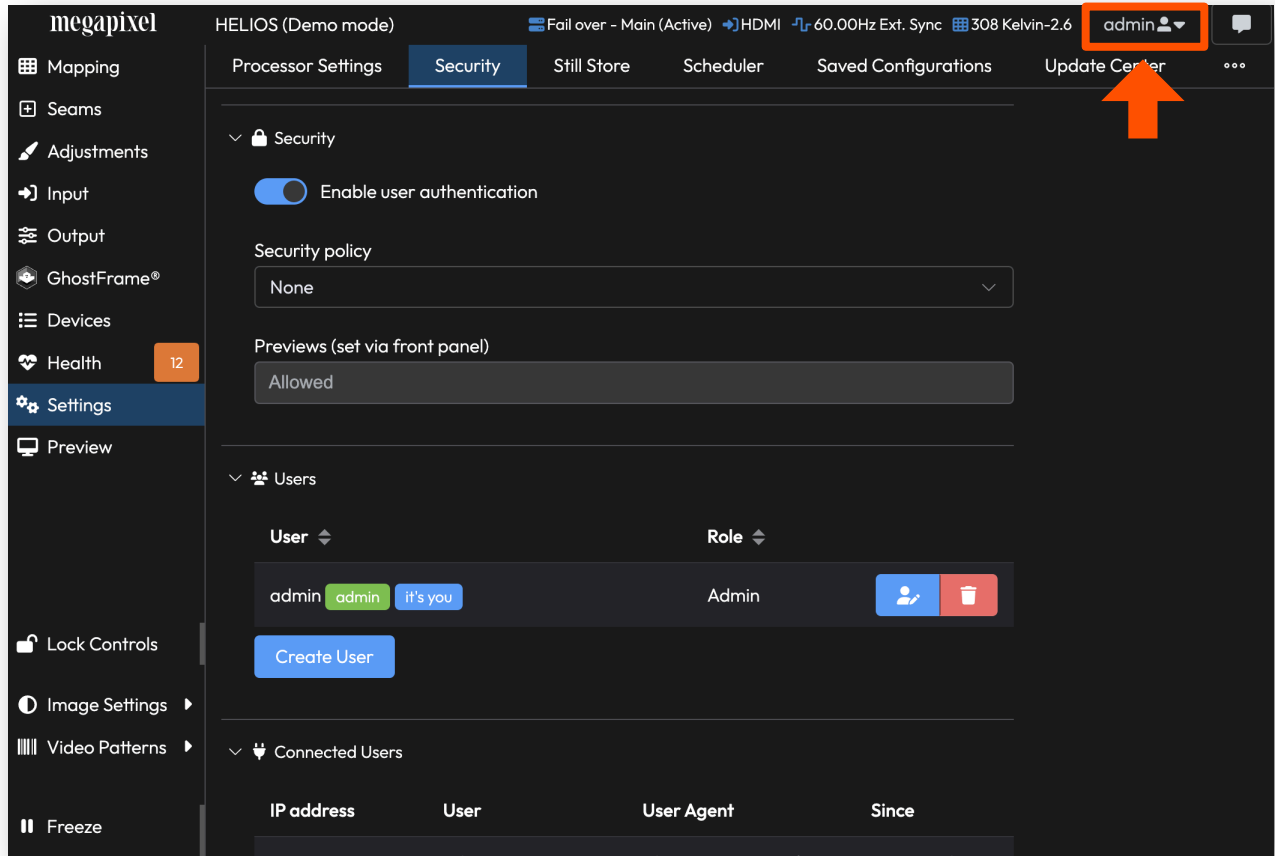

Figure 163: User list

Select the user button to **Sign out** or change the password.

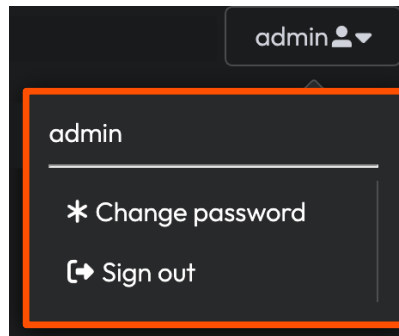

Figure 164: Sign out button

5.11 Security (Advanced) User Authentication

Manage users with the edit and delete buttons. Use the edit icon button to change the password for a user or to block a user. If a name change is required, it must be created as a new user.

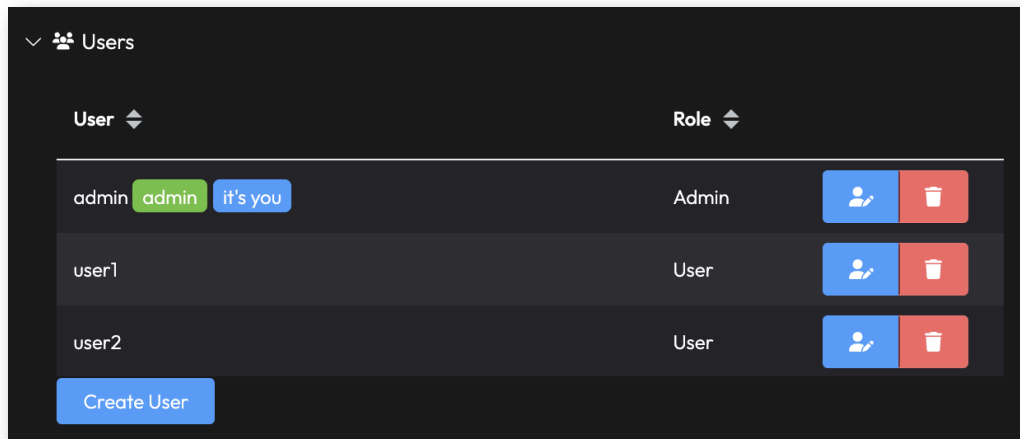

Figure 165: User list

If a user has been blocked, an amber notification will appear next to the user in the user list. Blocked users are not allowed to log in.

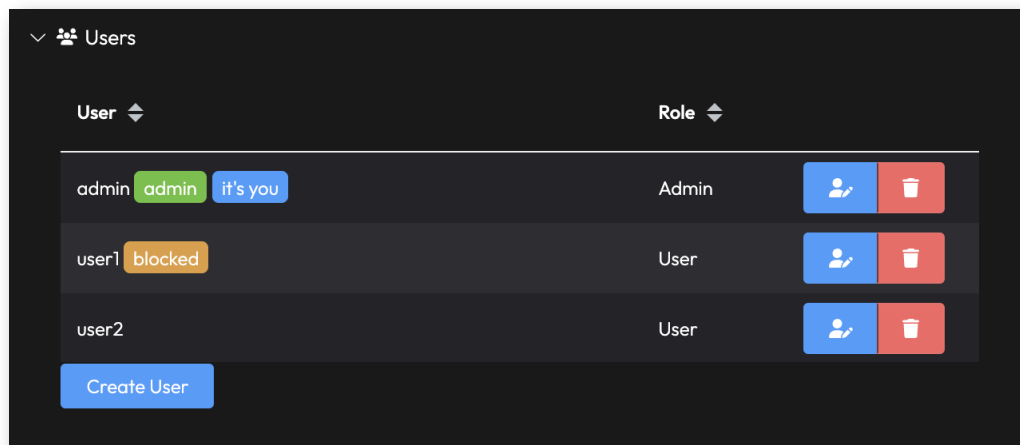

Figure 166: Blocked user

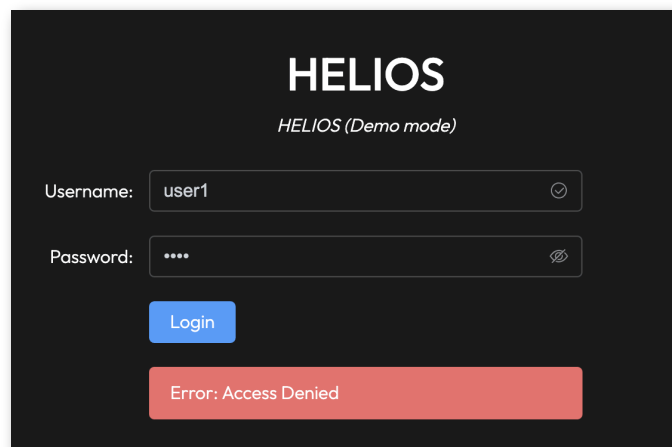

Figure 167: Access denied

5.11.1 Security (Advanced) Previews

The Previews mode defines whether the system will serve video preview images over the network. The Previews mode is adjusted from the processor's front-panel LCD. This setting is only accessible from the front-panel LCD, does not propagate through a processor stack, and requires physical access to the HELIOS® to adjust.

There are four (4) modes:

Allowed – Previews are available on the front-panel LCD and to all connected clients (LAN and Cloud).

LAN only – Previews are available on the front-panel LCD and to clients on the same subnet as the processor. No cloud or routed access is permitted, and previews are not included in support archives.

Blocked – Previews are shown on the front-panel LCD, but are not available to any remote clients. This is useful when HELIOS® is in a secure IT room and only local operators should see previews.

Disabled – All previews are disabled everywhere. The front-panel LCD no longer displays video previews, and remote clients do not receive preview images.

When previews are blocked or disabled, preview API requests return a 403 response and the Preview UI shows a lock icon instead of live thumbnails.

Mode	Front Panel Previews	LAN web UI previews	Cloud / routed previews	Preview API responses
Allowed	Shown normally	Shown normally	Shown normally	200 with image data
LAN Only	Shown normally	Shown for clients on same subnet only	Not available	200 for LAN clients; 403 (no image) for non-LAN clients
Blocked	Shown normally	Not available	Not available	403 (no image)
Disabled	Not Shown	Not available	Not available	403 (no image)

The current mode is shown on the **Security** page under **Previews (set via front panel)**.

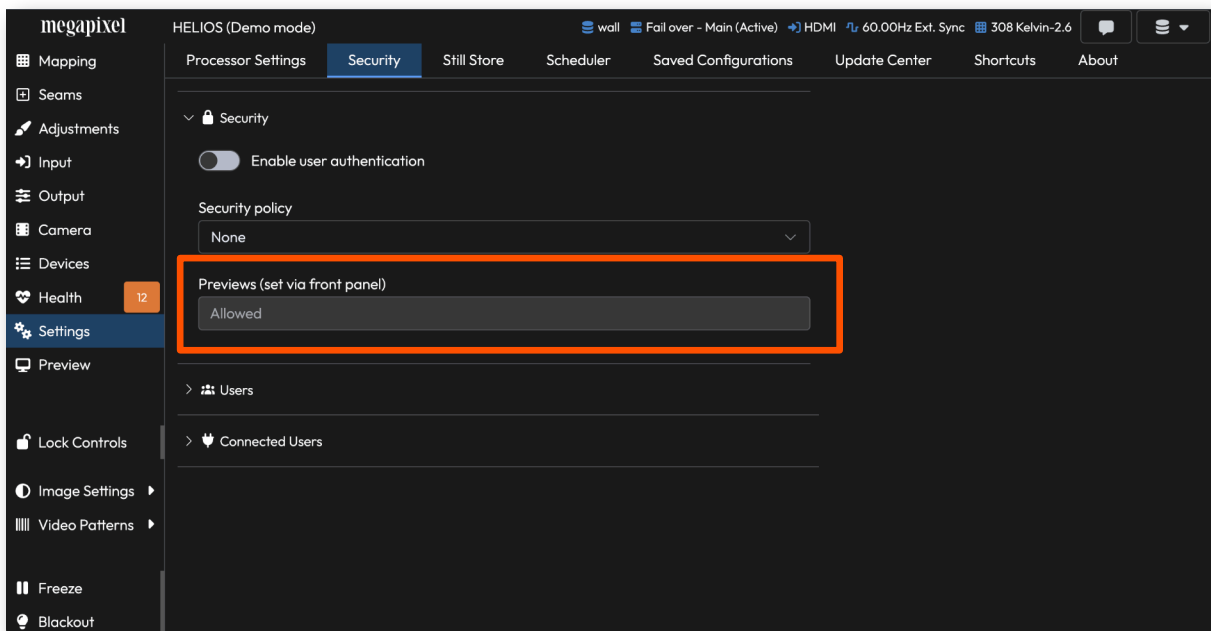

Figure 168: Previews mode

5.11.1 Security (Advanced) Previews

For details on how these modes appear in the user interface and affect live thumbnails, see Section 5.18 [Preview Pane](#).

To change the Previews display mode:

1. On the front panel, press the encoder to open the main menu and select **Settings**.



2. Select **Security**, then select **Previews**.



3. Turn the encoder to choose **Allowed**, **LAN only**, **Blocked**, or **Disabled** and press the encoder to confirm.



5.12 Still Store

The HELIOS® Still Store feature lets users import, organize, and display high-resolution JPEG and PNG images directly within the HELIOS®. Still Store integrates with [On Input Failure](#) and global [Video Pattern Selection](#). Still Store allows images to be used as reference visuals or fallback content in critical video workflows.

Purpose:

- Add still images (JPEG and PNG) to HELIOS®.
- Display stills individually or in a carousel.

Specifications:

- Max supported resolution: 8192 × 4320 pixels.

Works with:

- Input > On Input Failure feature
- Global Video Pattern Selection

Using Still Store:

- By default, all loaded images appear in the carousel.
- Show a still → Click the Play icon.
- Show only favorites → Select Favorites in the Video Patterns window.
- Managing Images:
 - Favorite a still → Hover over the image and click the Star icon.
 - Remove a still → Hover over the image and click the Trash Can icon.
 - Download a still → Right-click → **Save Image As...**

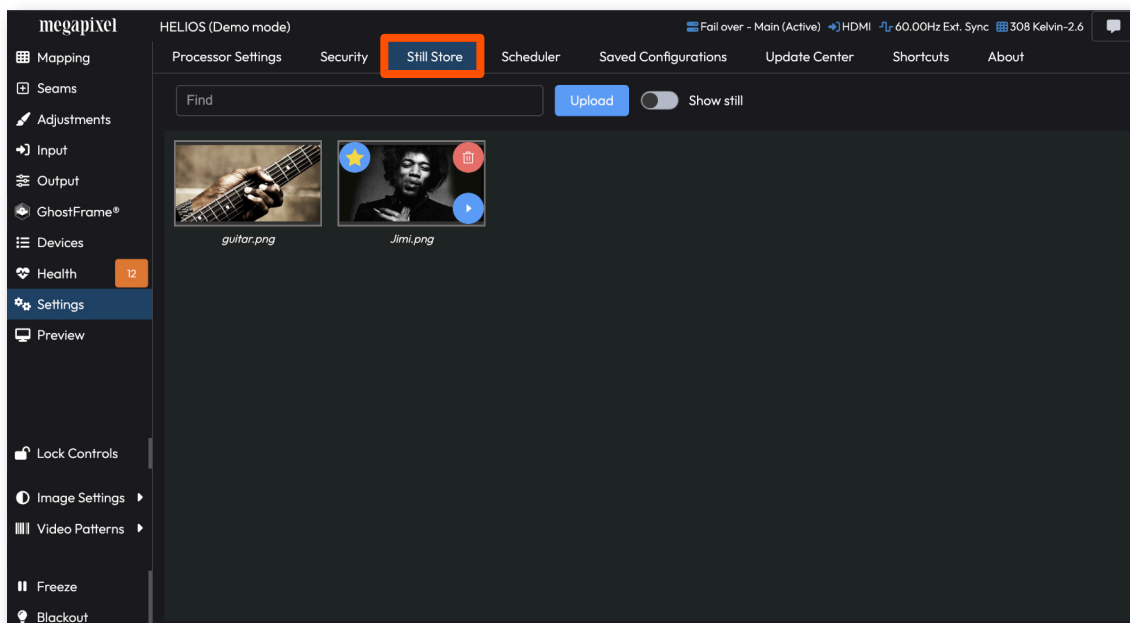

Figure 169: Still store

5.13 Scheduler (Advanced)

The HELIOS® scheduler can be found under **Settings > Scheduler**. Use the scheduler to have HELIOS® make system changes at a predetermined date and time. The HELIOS® scheduler needs a connection to an NTP server so that it can retrieve the current time and date. HELIOS® is usually configured to make a WAN internet connection to an NTP server such as **pool.ntp.org**. In some security-conscious situations, only a LAN connection is available to the HELIOS®. HELIOS® also supports NTP servers on a LAN. Enter the IP address of a local NTP server (**Processor Settings > Networking**) to have HELIOS® use it instead.

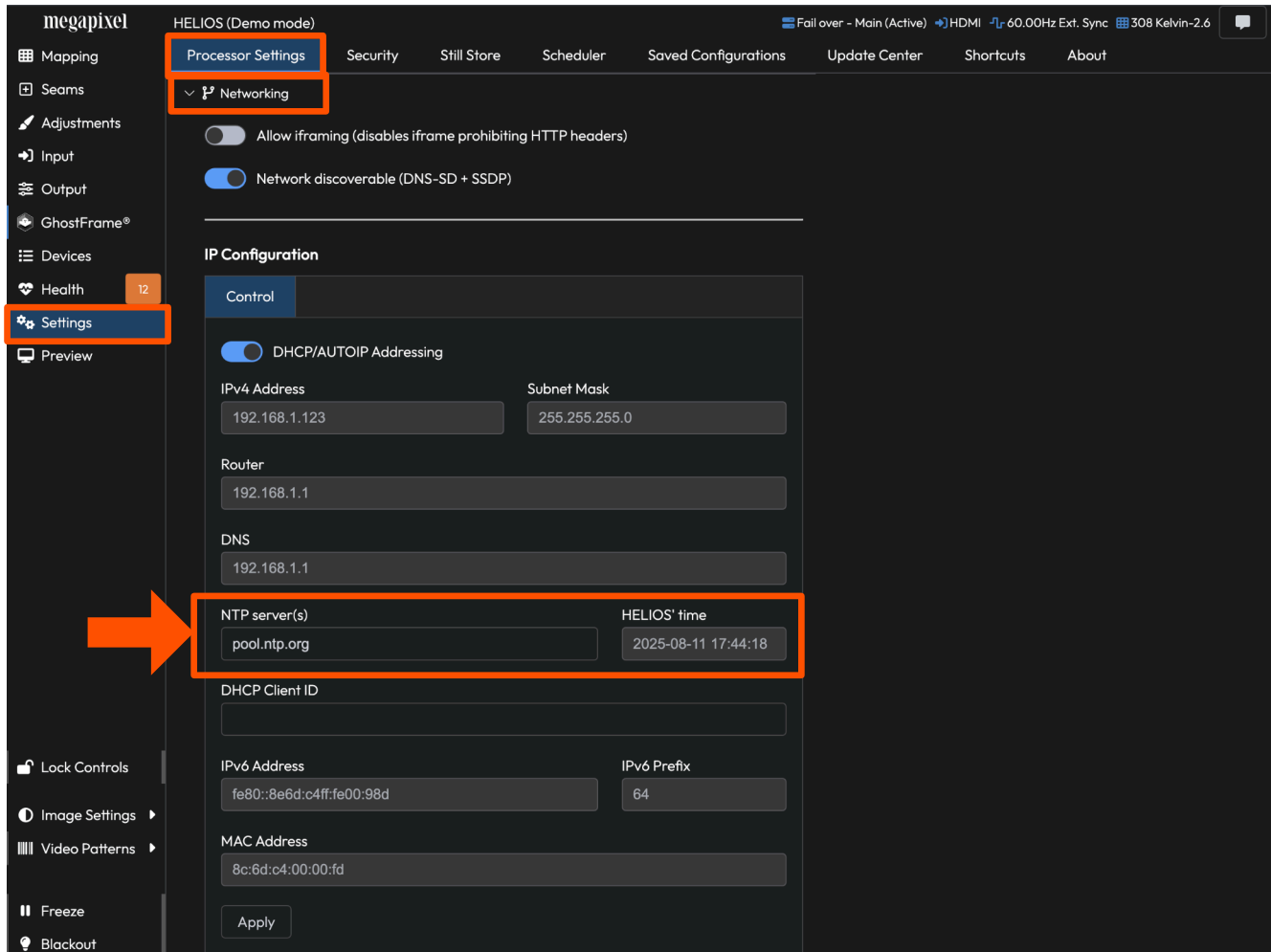

Figure 170: NTP server IP Setting

5.13 Scheduler (Advanced)

Press the **Add entry** button to create a scheduled event.

Press **Add failover** to add a failover entry to be executed if the scheduler is not runnable. The scheduler will not be runnable if HELIOS® cannot find the NTP time server after a reboot. The failover feature is useful in cases where HELIOS® loses power after executing a schedule to put brightness at a low level. When power is restored, HELIOS® will continue at that low brightness level and stay that way if it is unable to determine the current time. By adding a failover entry, HELIOS® will instead, adjust the brightness to the failover's predetermined level.

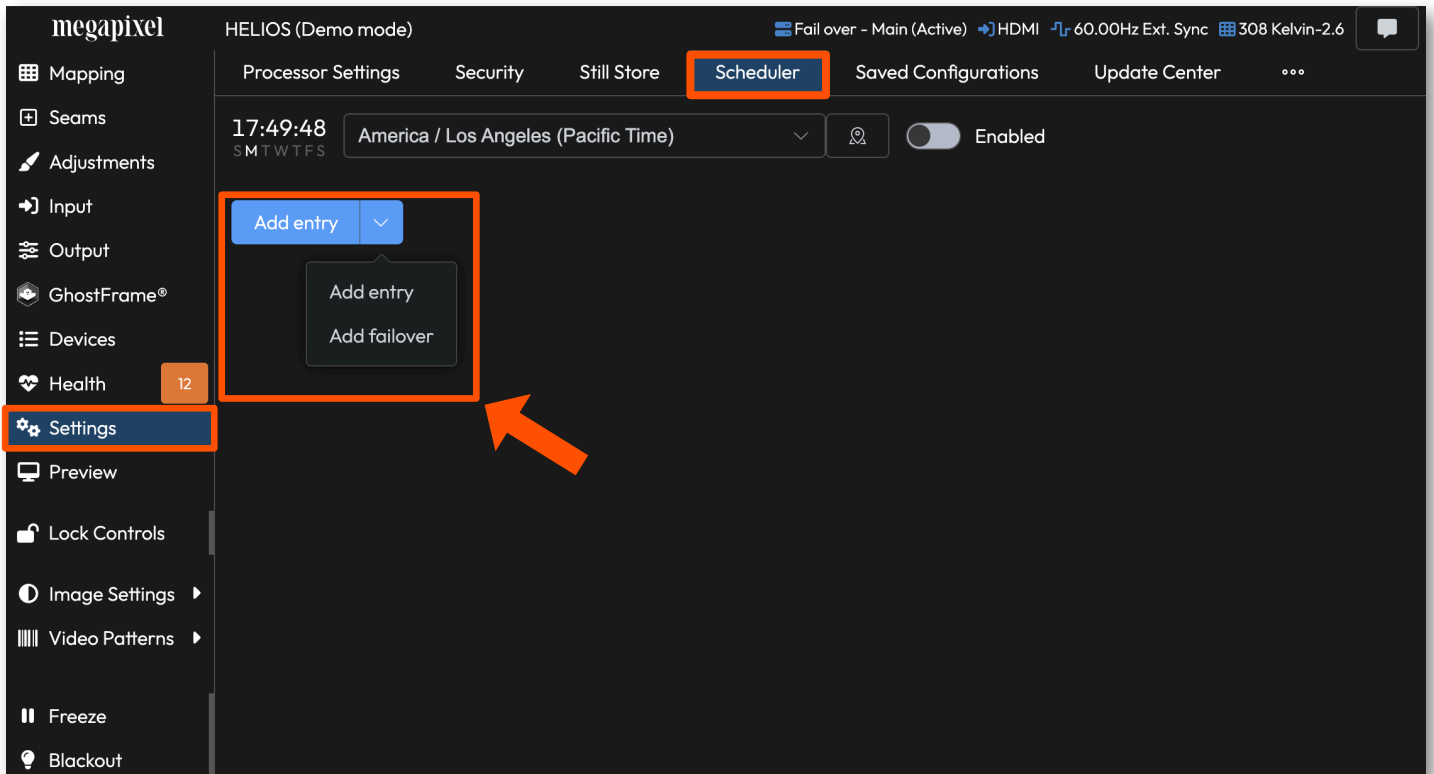

Figure 171: Scheduler Add entry

5.13 Scheduler (Advanced)

In the scheduler form window, set the time and date of the event. The **Weekdays** and **Weekend** buttons are shortcuts to manually selecting only weekends or weekdays. Once the time and date are set, enable one (or more) of the listed functions (**Brightness**, **Blackout**, **Input**) and set the desired value. For more complex configuration changes create a custom configuration on the **Settings > Saved Configurations** tab. Then, return to the **Scheduler**, enable **Apply config** and select the configuration using the **Apply config** dropdown (orange rectangle below).

Figure 172: Scheduler form

One entry exception rule — If there is only one entry in the schedule, HELIOS® will run that entry only when its scheduled time exactly matches the current time. This applies even after HELIOS® is rebooted or the scheduler is disabled and then re-enabled.

HELIOS® treats a single schedule entry differently from multiple entries. This is because, during testing, users often expect to set one schedule entry and have it trigger only at the specified time.

When there are multiple schedule entries, HELIOS® operates as a period-based scheduler. However, if a single entry were treated as a period-based entry, it would appear to run continuously. Without a second entry to define an end time, that single entry’s “active period” would cover the full cycle (for example, from 09:15 Monday to 09:15 the next Monday).

Figure 173: Single scheduler entry

5.13 Scheduler (Advanced)

Period-based scheduling — With more than one entry in the schedule, HELIOS® runs as a period based scheduler. The following is an example. In Auckland it's 6:47am, setting the screen to 100% brightness, as it's in the 05:00 to 17:45 period. If HELIOS® is rebooted or the scheduler is disabled/re-enabled while the time is in this period, the HELIOS® will set the brightness to 100%. HELIOS® does not wait for the time to match up as it does when there is only one entry in the schedule.

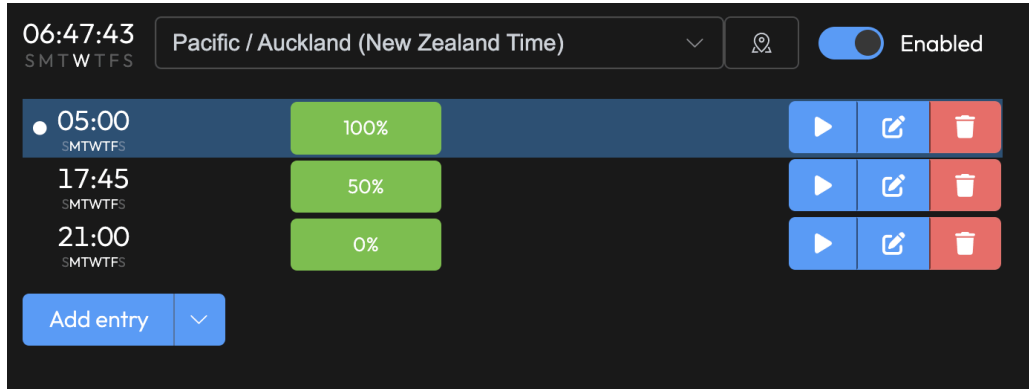

Figure 174: Period-based example one

In example two, it is 10:53pm in Dubai. The display is set to 0% brightness, as it's in the 21:00 to 05:00 period.

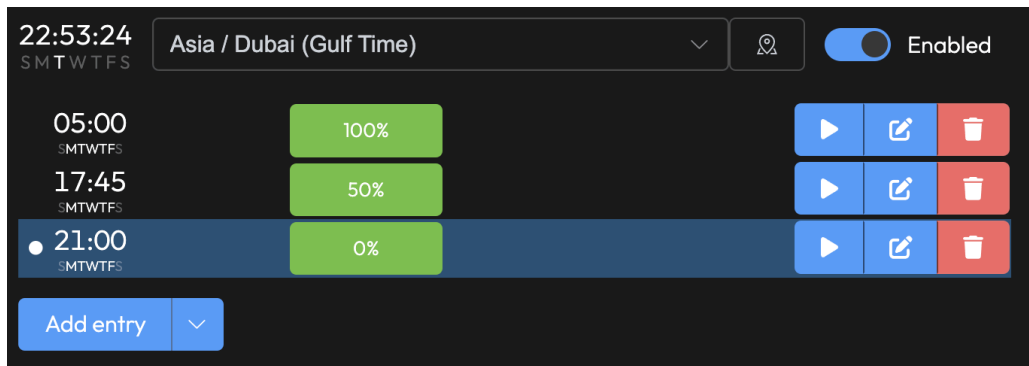

Figure 175: Period-based example two

5.13 Scheduler (Advanced)

Scheduled tasks are executed whenever:

- HELIOS® starts up
- HELIOS® moves into the next scheduled period
- The schedule is changed
- The task is manually triggered

The Scheduler can be quickly enabled/disabled using the top right **Enabled** toggle. HELIOS® shows a small calendar icon (see arrow in the image below) at the top of the interface when the scheduler is enabled.

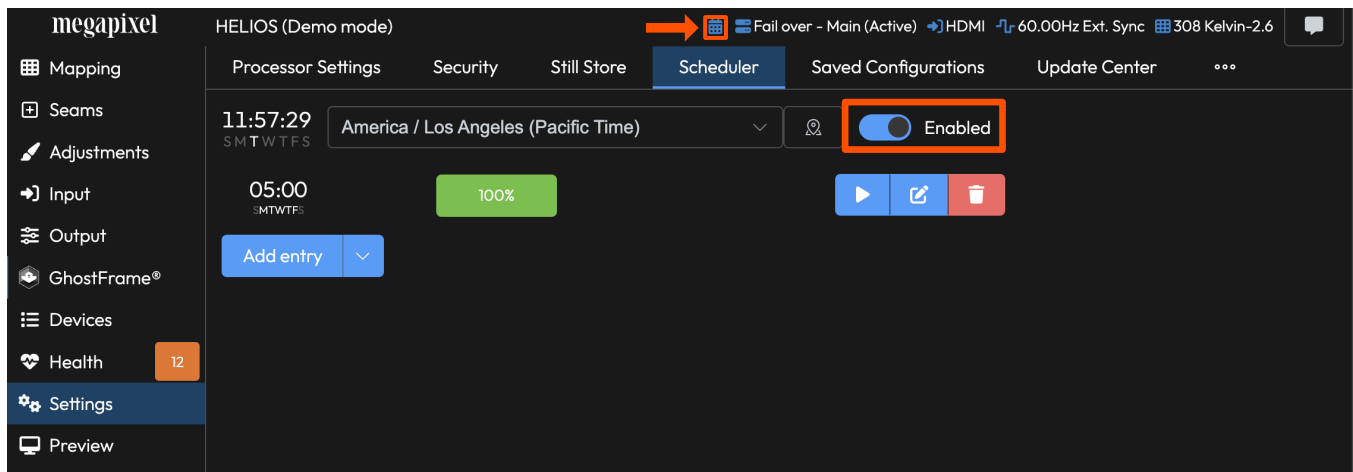

Figure 176: Scheduler enable toggle and clock icon

5.14 Saved Configurations

Saved Configurations are used to export a collection of settings. This is useful for configuring a spare unit or to save a progress state while building a new system. It is also the recommended method for documenting and storing full configurations.

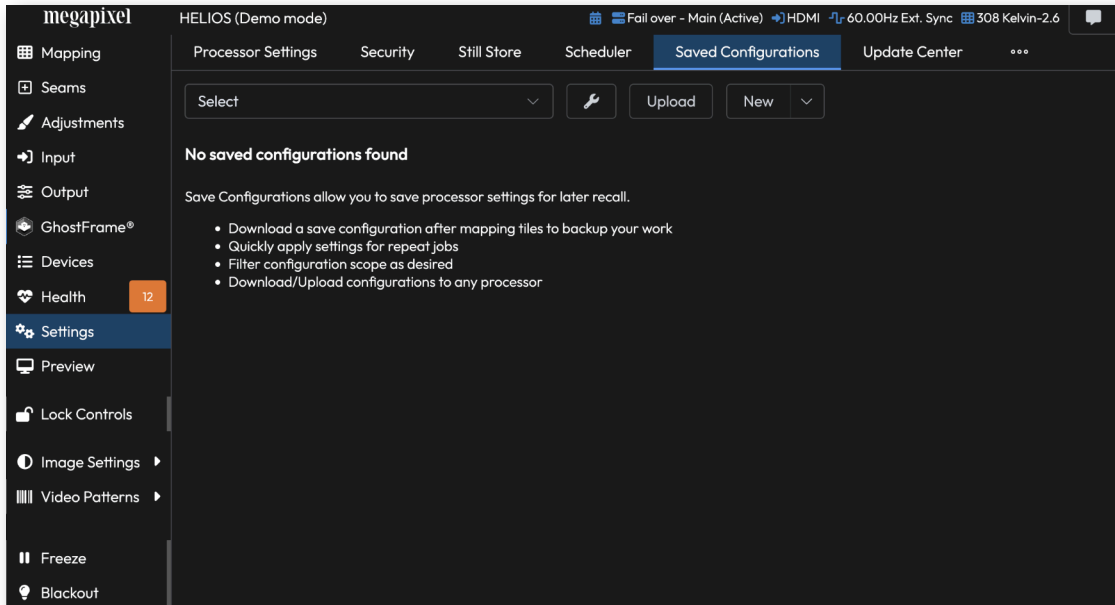

Figure 177: Saved configurations

HELIOS® has a factory default configuration. Select the **Factory Default** configuration from the dropdown menu to load the file. With this file loaded, and the **Only show changes** toggle switched on, HELIOS® displays all the settings that deviate from the factory defaults. In this example, the only change is the creation of one (1) **Mapping Group**. Press the **Apply Configuration** button to return the HELIOS® to factory default settings. In the case of the example below, one (1) **Mapping Group** will be deleted.

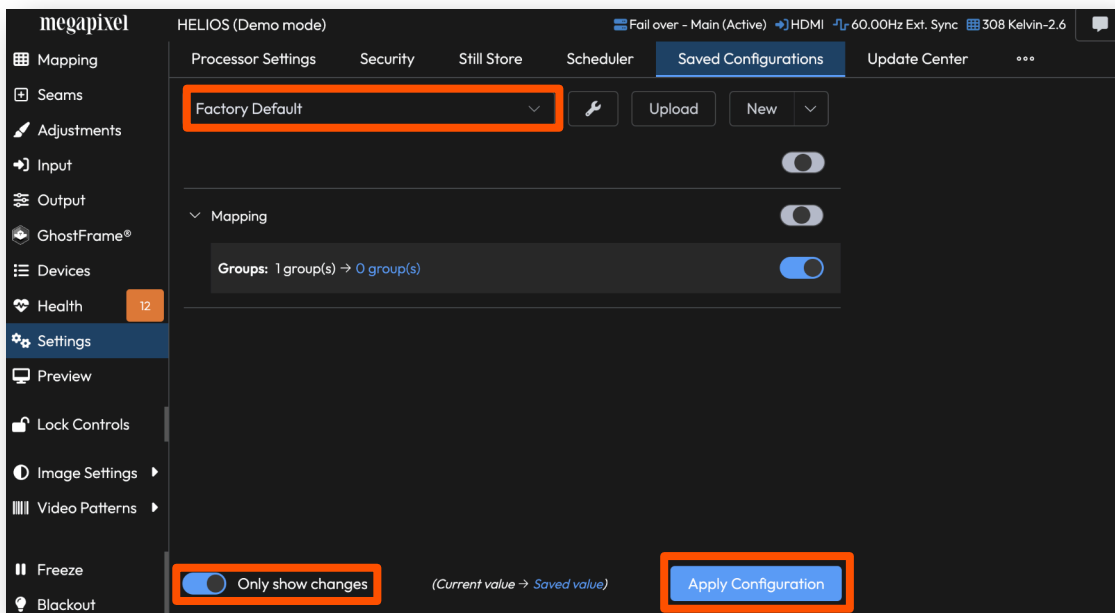

Figure 178: Factory Default

5.14 Saved Configurations

To create a new configuration, press the **New** button.

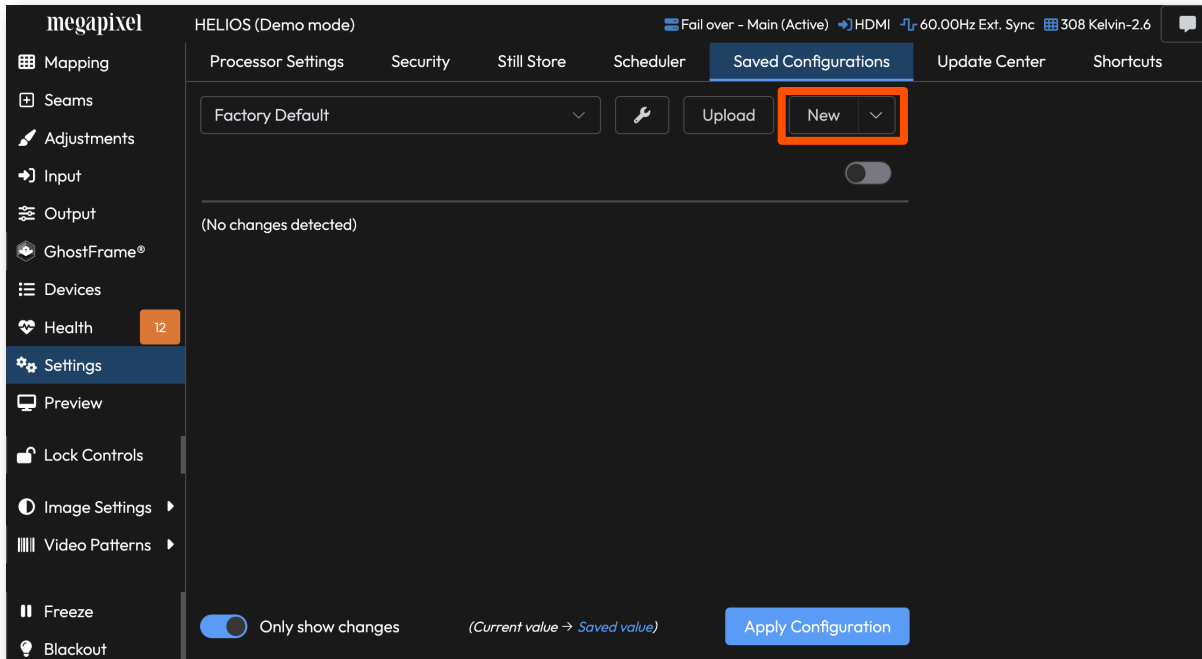

Figure 179: New configuration

The system automatically assigns a title based on system time and date, which can be customized by editing the name field. Below the name of the configuration is a list of system parameter filters. If certain parameters are not desired, use the toggle to remove that particular parameter. For example, inputs often have similar color settings across processors in a multi processor system. Rather than manually entering the same input color adjustments to all processors, create a new saved configuration with input settings enabled and upload to each processor.

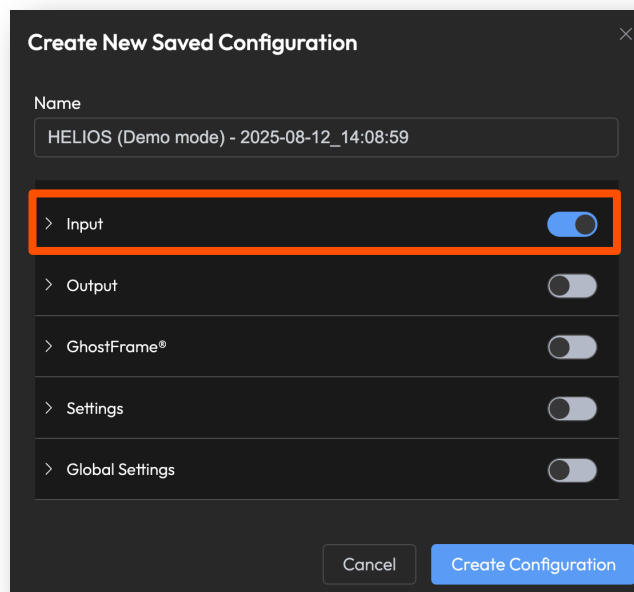

Figure 180: Settings filters

5.14 Saved Configurations

The **New** button has 'quick access' file management functions under the dropdown on the right of the button.

Function	Description
Download	Retrieve the configuration as a file
Update	Overwrite the existing configuration with recent changes
Rename	Change the name of the file
Clone	Duplicate the file
Delete	Remove the file

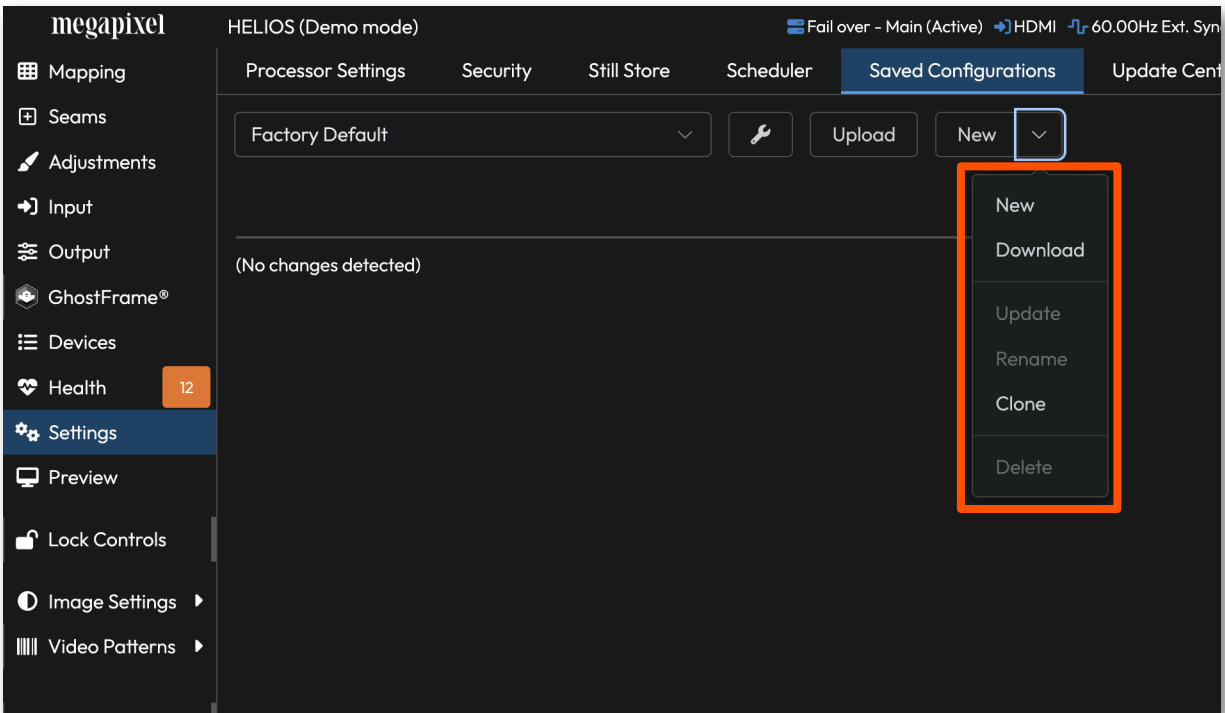

Figure 181: Blank 'Saved Configurations' pane

5.14 Saved Configurations

How to move configuration files:

The following steps detail how to move a configuration file from one processor to another.

1. After the configuration file has been created, select the file with the dropdown menu. Then use the disclosure triangle on right side of the **New** button to select **Download** from the options.

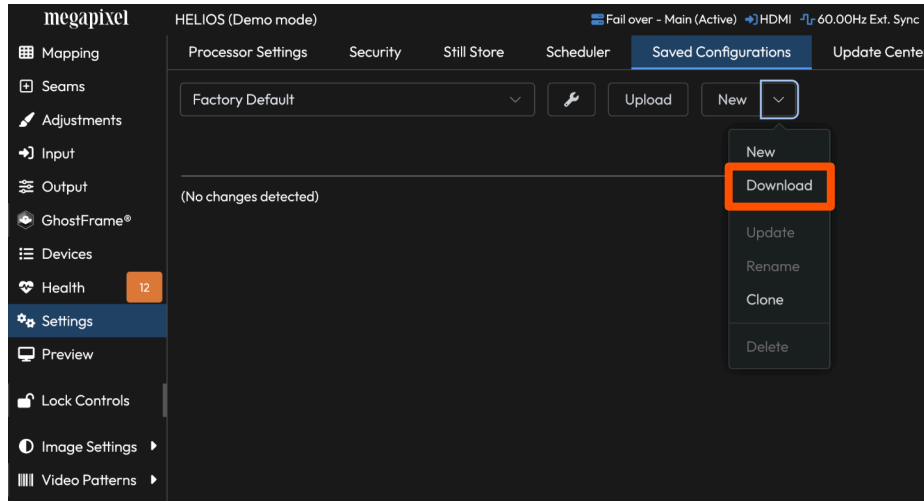

2. Connect to the target processor, return to the **Saved Configurations** tab and **Upload** the configuration file.

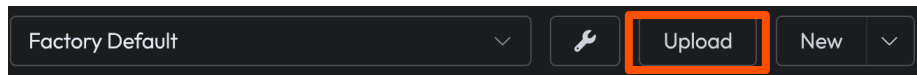

3. **Apply Configuration** to activate the file.

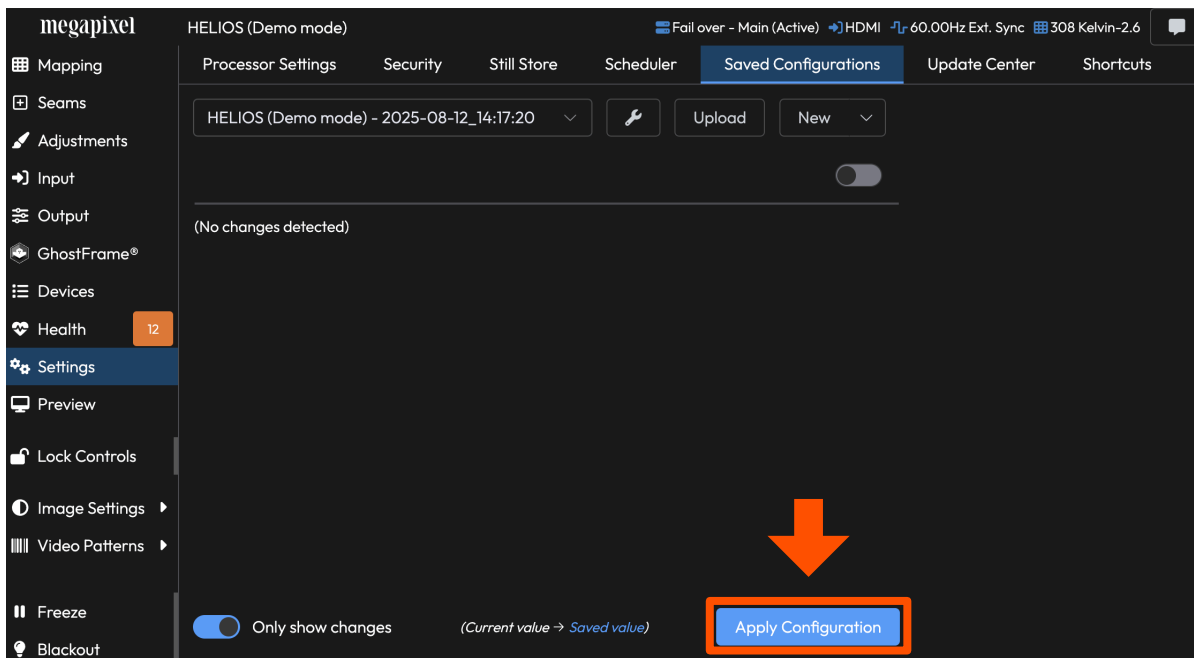

5.15 Update Center

The **Update Center** is used to manage the firmware, software, and operating system updates to the HELIOS® system components. Update packages can be retrieved to the HELIOS® using the **Check for updates...** button.

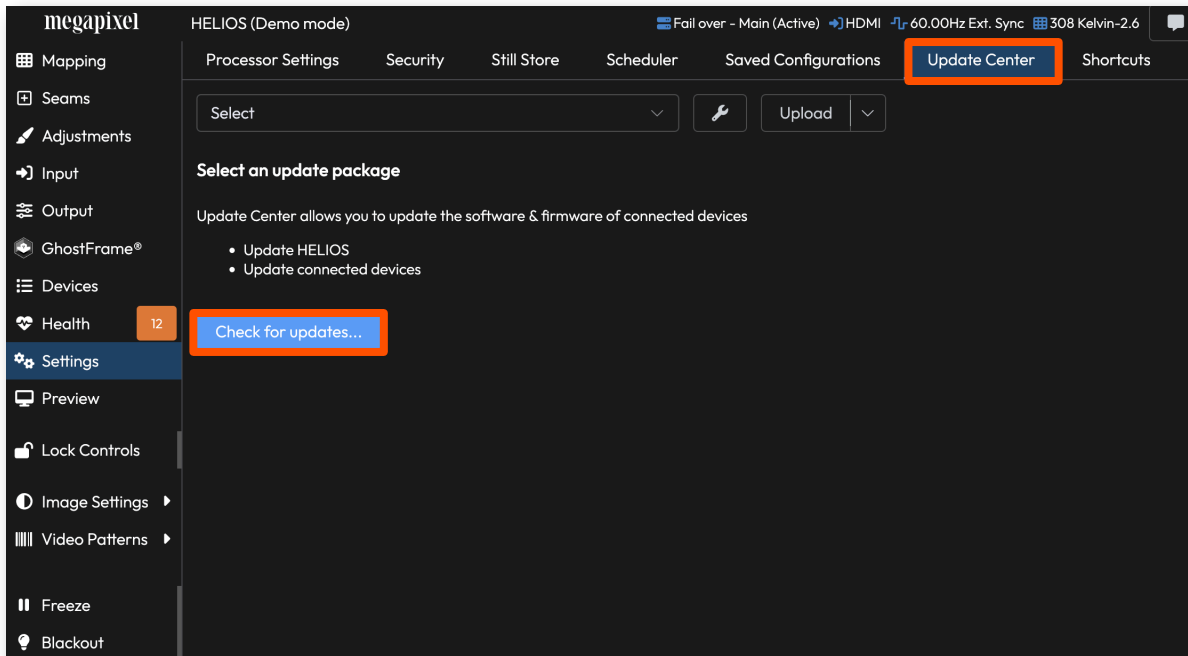

Figure 182: Update Center

A small green or yellow arrow indicates whether the package is an upgrade or downgrade to the existing software. A white arrow indicates that there would be no change. Select either an existing package from the list or add a new one to the HELIOS®, with the **Upload** button. All of the Megapixel packages end with the '.mvrp' extension. The HELIOS® packages will be labeled with 'helios' at the beginning of the file name. Tile packages begin with 'px1' (the name of the receiver card). Network Switch packages will begin with 'helios-switches'. Upgrade steps are provided on the following two pages.

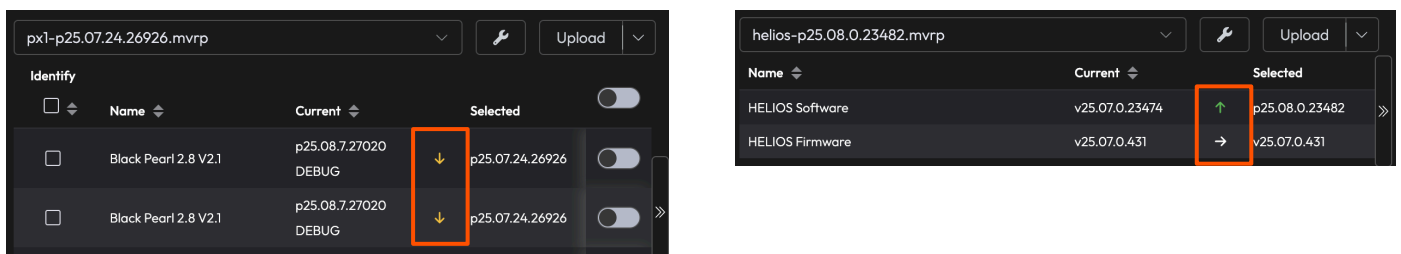
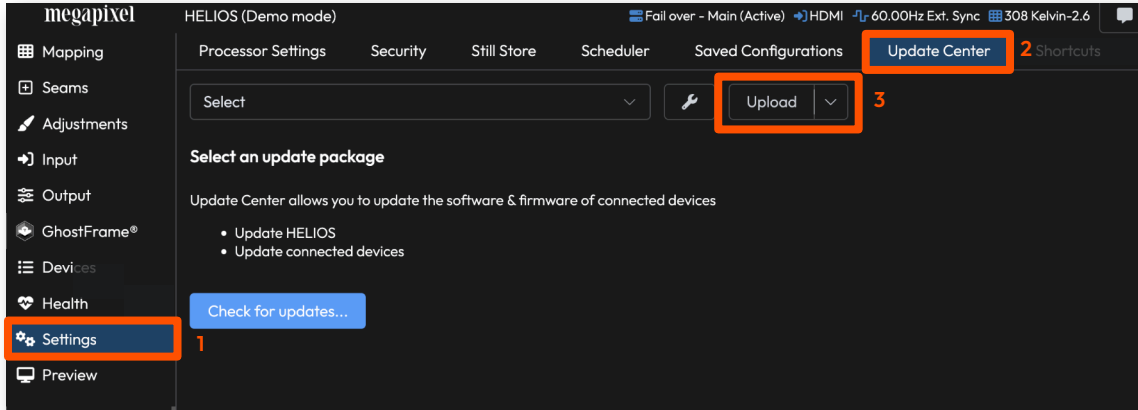

Figure 183: Available updates window with upgrade, no change, and downgrade arrows

5.15.1 Software upgrade steps

1. Navigate to: **Settings > Update Center** and select the **Upload** button.



2. Browse to the current software .mvrp file on your computer and upload it. A progress bar will appear during the upload.

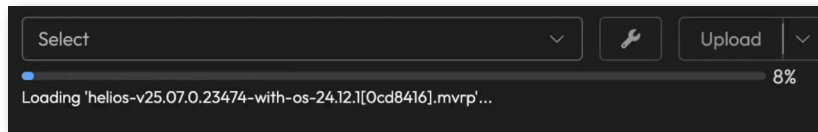

3. After the package has uploaded, select the new .mvrp package from the dropdown list, then click **Start**. The upgrade process will show a progress bar.

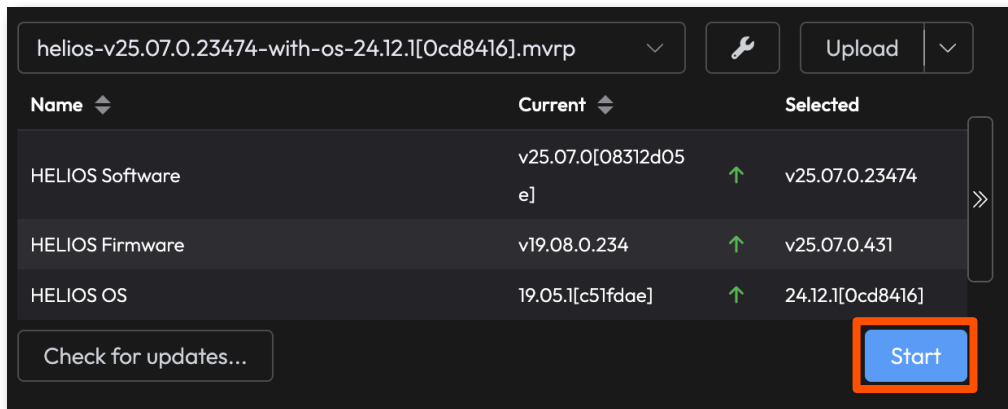

4. During the upgrade, a **Connection lost** message is shown as HELIOS® extracts and installs the package.

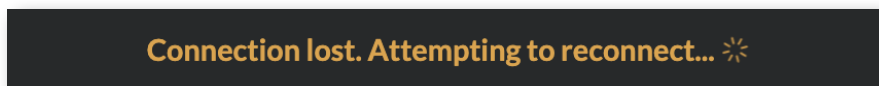

5. Once the upgrade is complete, the software loaded should be listed as the current software.

5.16 Shortcuts

The shortcuts menu provides a list of functions that have been assigned keyboard shortcuts. The information here is also available with the press of **SHIFT + ?**.

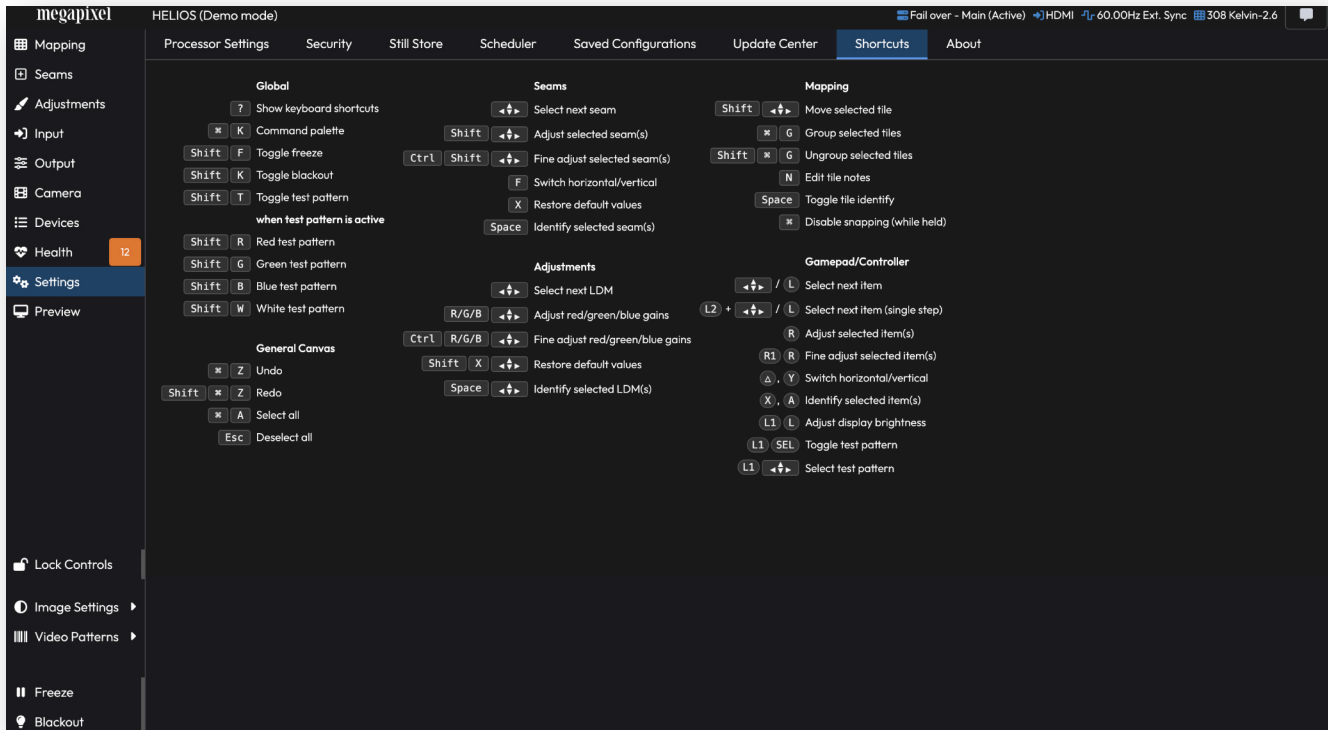

Figure 184: Shortcuts tab

5.17 About

The **About** tab displays the current HELIOS® version number along with important links for contacting support. Press the **Download support archive** button to save a zip file containing HELIOS® system information files that are essential to obtaining new system licenses and are helpful for troubleshooting.

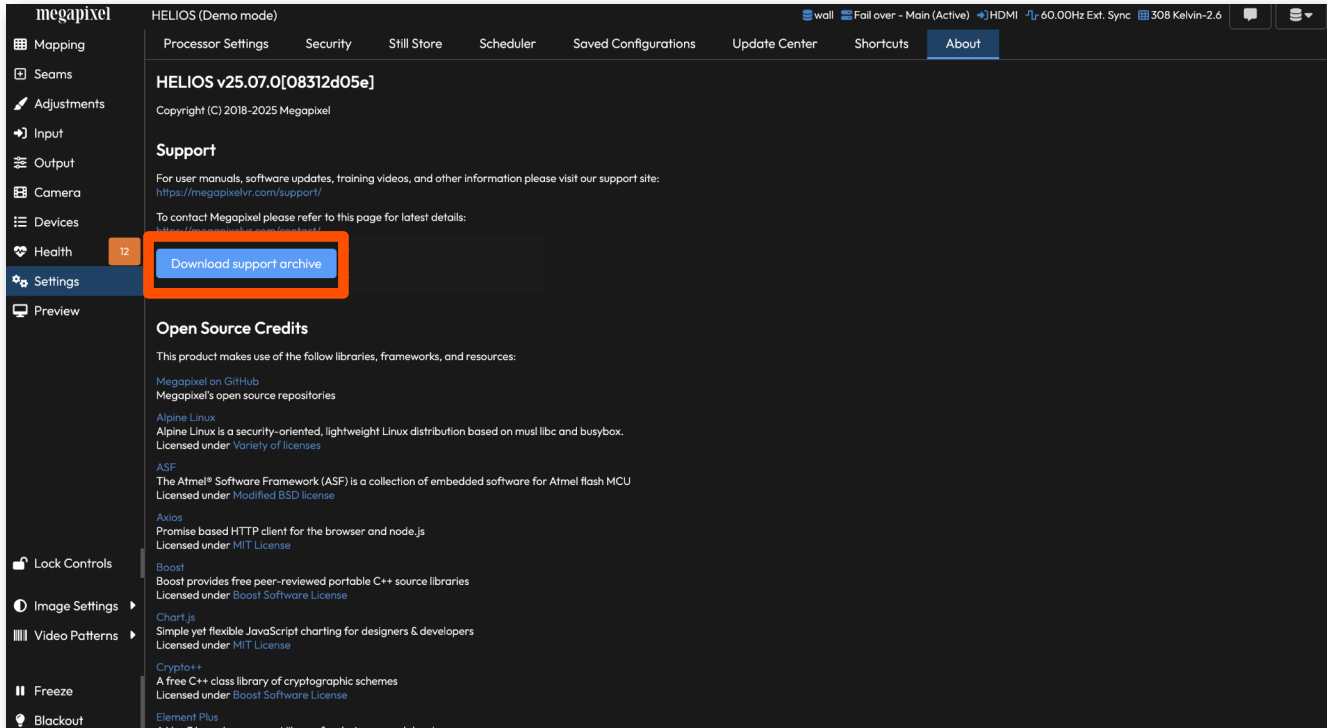
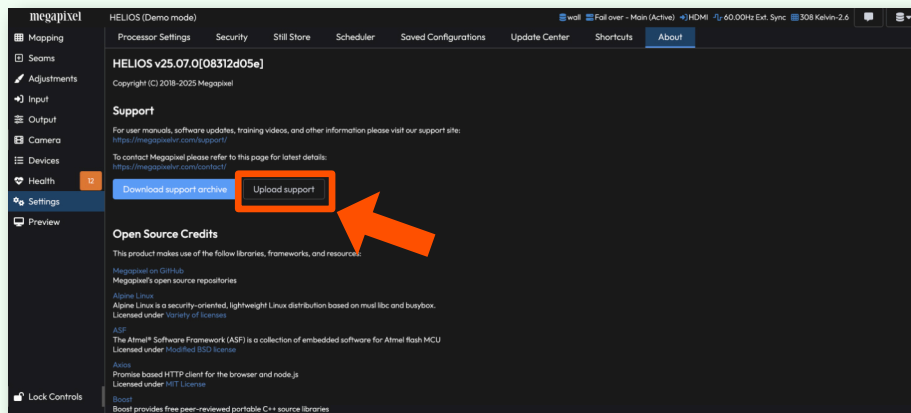

Figure 185: About tab

TIP: Support archives can be uploaded and inspected at the HELIOS® demo website **About** page. Visit <https://demo.megapixelvr.com> and create a login if needed. Once on the **About** page, press the **Upload support** button. Navigate to a support archive saved from a real HELIOS® and upload it to the demo site. The demo site will switch from using the demo backend to the support archive data. Reload the website to return it to using the usual demo backend.



5.18 Preview Pane

The **Preview** pane displays a low resolution, low frame rate version of actively connected inputs. The window layout will reconfigure based on which inputs are active and which input is selected. In the example below the HELIOS® unit is receiving a quad SDI signal, but the unit has HDMI selected as the current input. Four (4) active SDI feeds are visible below a black HDMI preview.

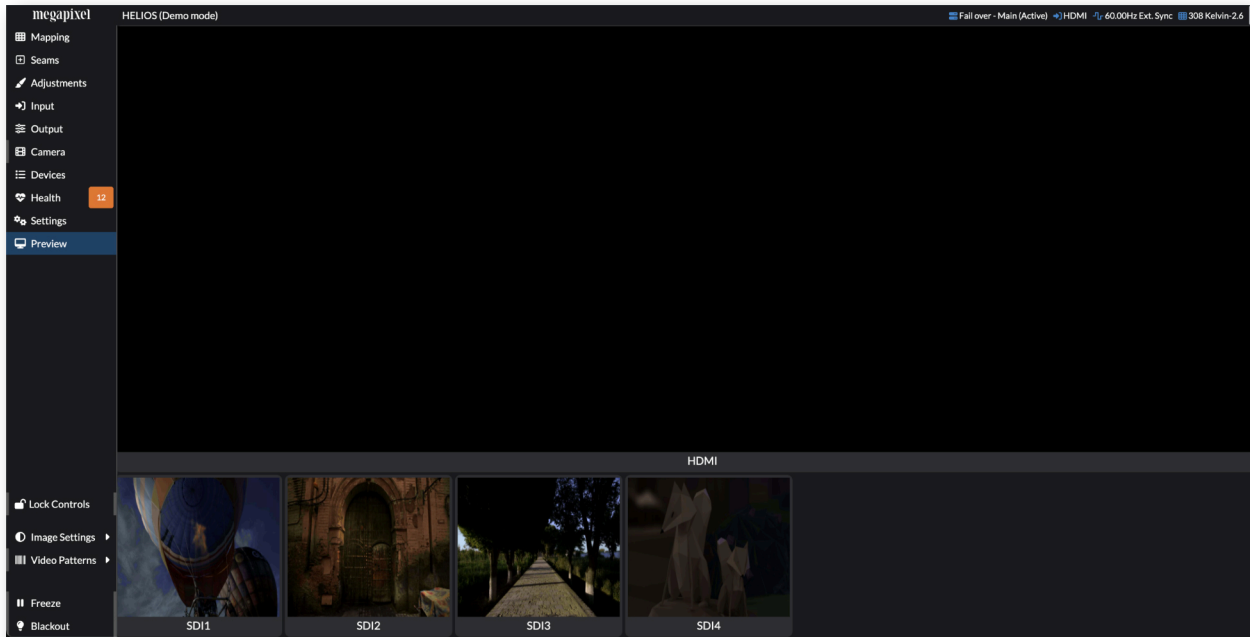

Figure 186: Preview pane — No HDMI input

In the example below **SDI1** has been selected as the input. The **Preview** pane shows **SDI1** maximized at the top. Other active, but not selected inputs are shown as thumbnails at the bottom of the pane.

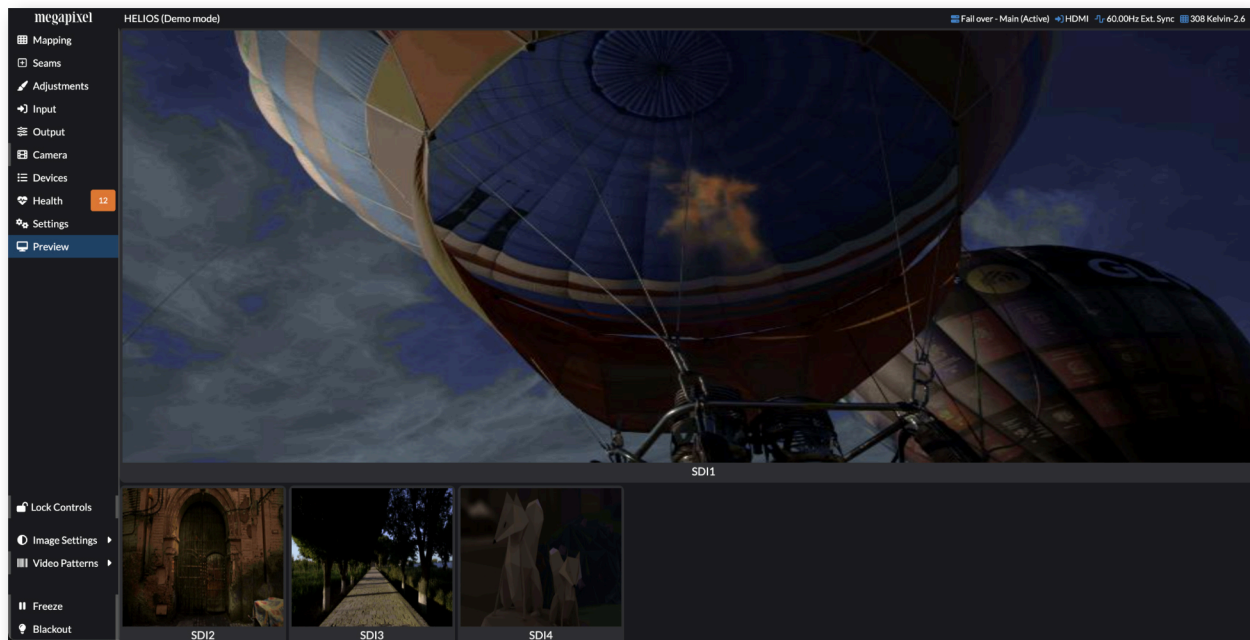

Figure 187: Preview pane — SDI1 selected

5.18 Preview Pane

With either of the Quad SDI (**SDI 1x4** or **SDI 2x2**) input options selected, the **Preview** pane stitches the four (4) SDI feeds together.

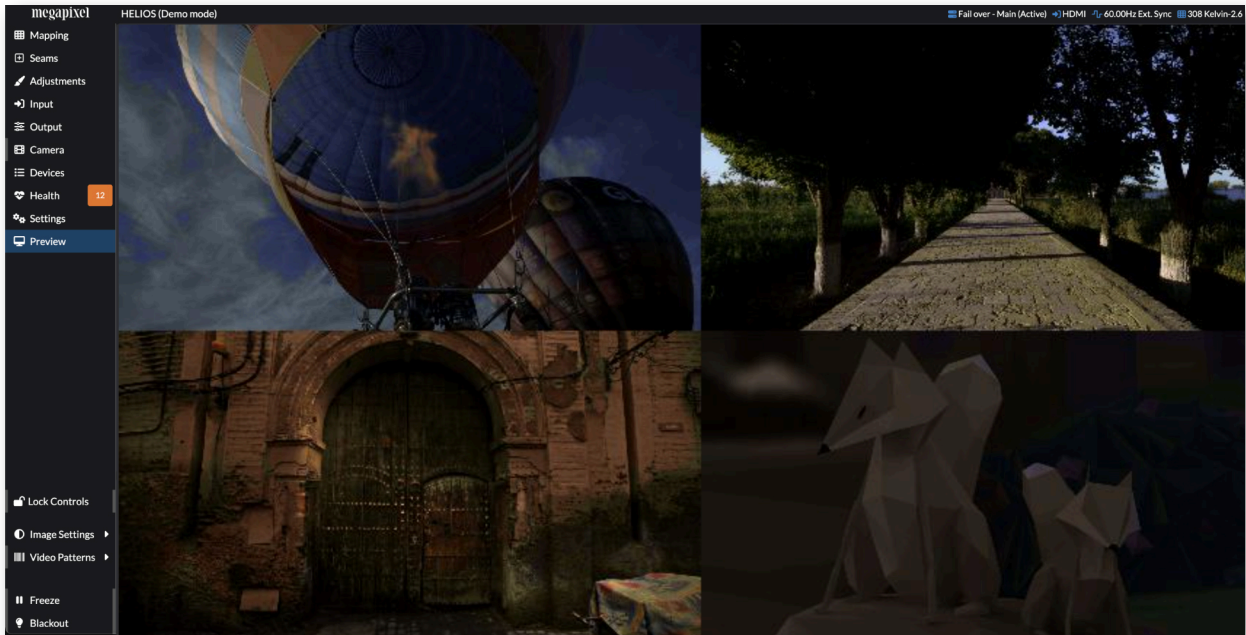

Figure 188: Preview pane — Quad SDI

Preview availability is controlled by the Previews mode described in Section 5.11.1 [Security \(Advanced\) Previews](#). When previews are **Blocked** or **Disabled**, the Preview pane shows a lock icon instead of live thumbnails and preview API requests return a 403 response; when set to **LAN only**, the pane is only available to clients on the same subnet as the processor.

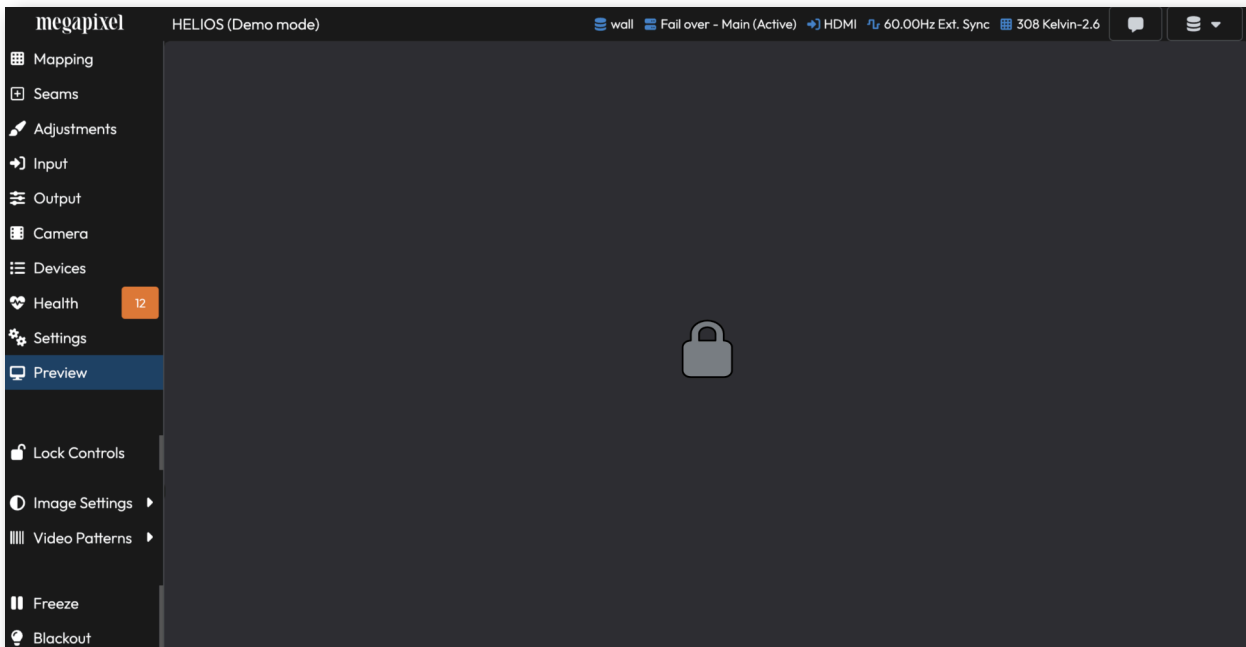

Figure 189: Blocked Previews

5.19 Seams Pane

Displays occasionally have minor intensity variations at physical tile seams, usually caused by inconsistent gaps between tiles. Before adjusting seams in HELIOS®, check the installation for hardware inconsistencies such as unengaged latches or tiles and LDMs that are not fully seated.

HELIOS® provides seam correction by adjusting the intensity of edge LEDs.

Two tabs are available:

- **Tile Seams** — each selectable region in the UI is the edge of a tile
- **LDM Seams** — each selectable region is an LDM (LED module) boundary

Adjusting a seam:

- Select the seam or seams to adjust. Only the relevant slider direction (horizontal or vertical) will be enabled based on your selection.
- Increase the slider value to brighten the seam; decrease to darken.
- When a seam has a non-zero value, the UI shows a lighter or darker bar as an indicator of the correction bias — this is not a representation of the amount of correction applied.
- Use the **Enable seam correction** toggle to compare (A/B) the display with and without seam correction to evaluate progress.

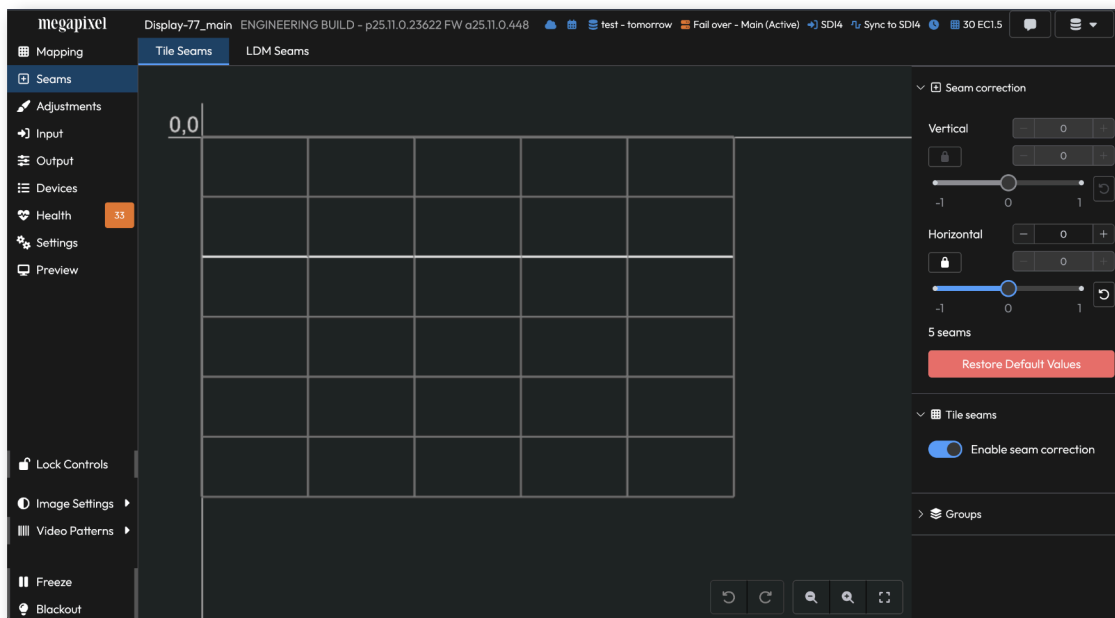



Figure 190: Tile Seams control

5.19 Seams Pane

Gradient mode:

Press the lock icon  to unlock gradient functionality. In this mode, control of the seam brightness is split in half:

- **Horizontal seams** — the left slider controls the left half of the seam; the right slider controls the right half
- **Vertical seams** — the top slider controls the top half; the bottom slider controls the bottom half

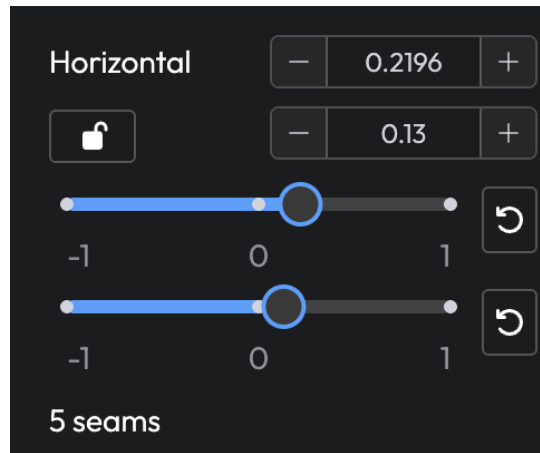

Figure 191: Seam gradient control

5.19 Seams Pane

We have found that video game controllers are well suited for the seam correction workflow. The HELIOS® UI supports Xbox and Playstation* controllers. The game controller connects via USB or Bluetooth to the laptop or mobile device that is running the HELIOS® web UI. Multiple users are supported as each browser connection can have a game controller connected.

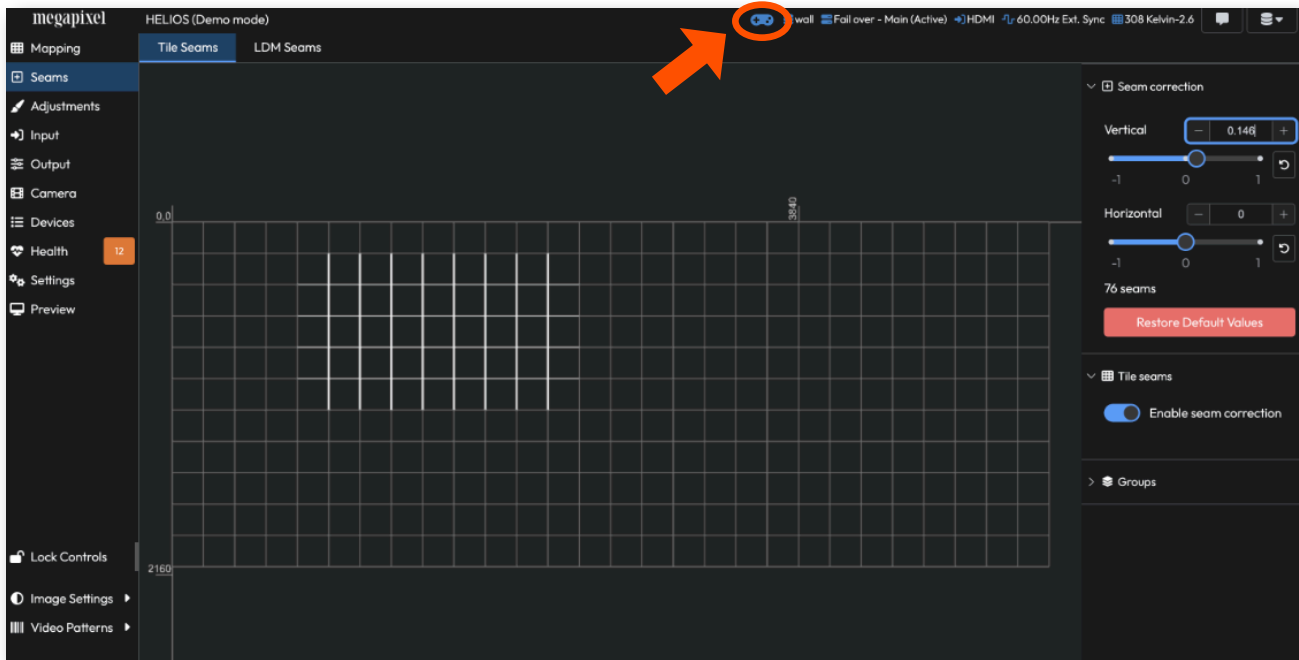

Figure 192: Seams pane game controller icon

Steps to set up a Bluetooth controller with a mobile host:

1. Begin with the controller turned off. Then, put the controller in pairing mode:
 - Xbox — press the Xbox button to turn on the controller. Then, press and hold the Connect button for a few seconds.
 - PlayStation — press and hold the PS and Share buttons at the same time until the light bar begins to flash.
2. Navigate to the Settings and ensure Bluetooth is turned on.
 - Find the name of the controller under Other Devices. Tap the name to connect.
3. With the web browser in focus and connected to HELIOS® press the X button on the controller.
4. A gamepad icon (see image above) should appear on the HELIOS® UI confirming the link with the game controller.

* Xbox is a trademark of Microsoft® Corporation. PlayStation is a trademark of Sony Interactive Entertainment Inc.

5.19 Seams Pane

The warning below is shown when a user connects to HELIOS® using the https:// protocol because each HELIOS® includes its own self-signed certificate. HELIOS® supports loading custom signed HTTPS certificates. See the [Networking \(Advanced\)](#) section for more information on loading custom HTTPS certificates.

As browsers move to requiring a secure context for gamepad support, users will need to use an https:// connection to enjoy gamepad powered seam correction. Existing http:// (no 's') connections will soon no longer register that a game controller is even connected.

This change was defined by the W3C, who are concerned with protecting the privacy and security of users on the internet. Megapixel is actively exploring options, but for now a user has to connect to HELIOS® using the https:// protocol to be able to use gamepads on Firefox and the other major browsers.

If a warning such as the one below appears when connecting to HELIOS® via https://, press the **Advanced...** button on the warning page and **Accept the Risk and Continue** to bypass the warning.

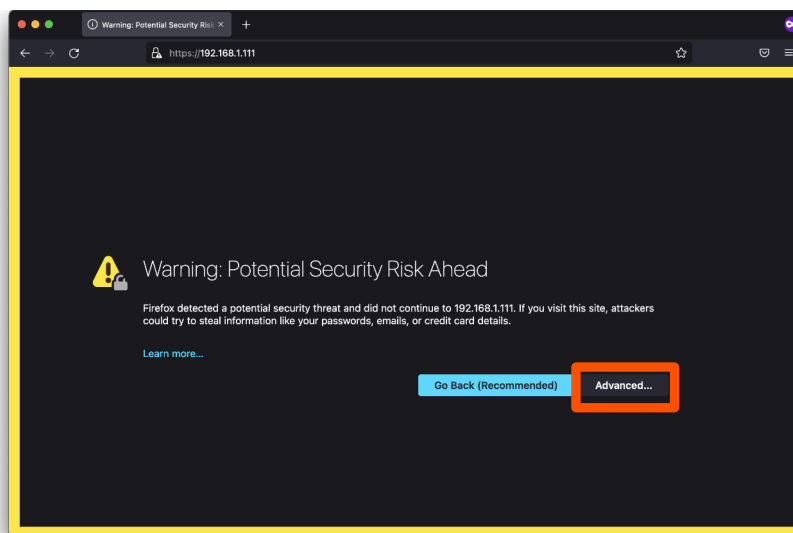

Figure 193: https:// warning 'Advanced'

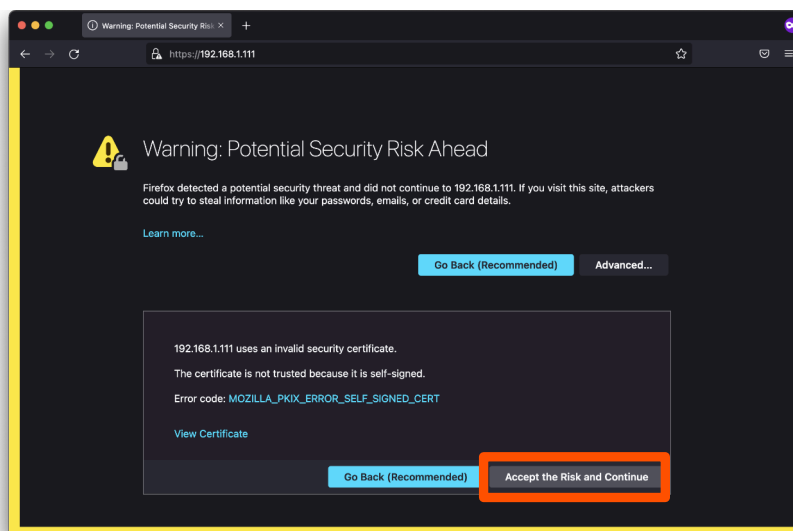

Figure 194: Game pad warning 'Accept the Risk and Continue'

5.19 Seams Pane

Seam selection — Both the D-pad and the left stick control seam selection. However, there is a key difference between the two. The D-pad moves the selection one seam per click, whereas the left stick is an analog control. The further the stick is pushed, the faster the selector moves across seams.

Adjust seam — Analog control of brightness for the selected seam.

Toggle H/V adjust — Toggles between Horizontal or Vertical seams.

X button — Flashes the selected seam. Since the seam will not remain highlighted while adjusting, it is easy to lose track of which seam is currently selected. This function helps identify the currently selected seam.

R1 — For fine control, press and hold the R1 button while using the analog stick.



Figure 195: Control assignment

Tips:

- Start on one side and work across the screen systematically.
- If multiple users are working, assign regions to each user.
- Check the screen from several view points and distances.

5.20 Adjustments Pane

The HELIOS® can adjust the RGB gains on individual LED modules (there is no full tile option). Gain adjustments at the LDM level are available if supported by the tile manufacturer and firmware. Select tiles and use the sliders to make the adjustments. The user interface will tint the tile region to show the color bias assigned to the tile. Shift+click selects multiple tiles. Alt+click selects individual LDMs (if individual LDM adjustment is supported).

Keyboard shortcuts are available for these controls. Use the **R/G** or **B** keys in conjunction with the arrow keys to coarse adjust the respective color gains (**Red**, **Green** or **Blue**). Use **Ctrl + R/G/B + arrows** to fine adjust the respective color gains. Use **SHIFT + ?** to show a list of all of the HELIOS® keyboard shortcuts.

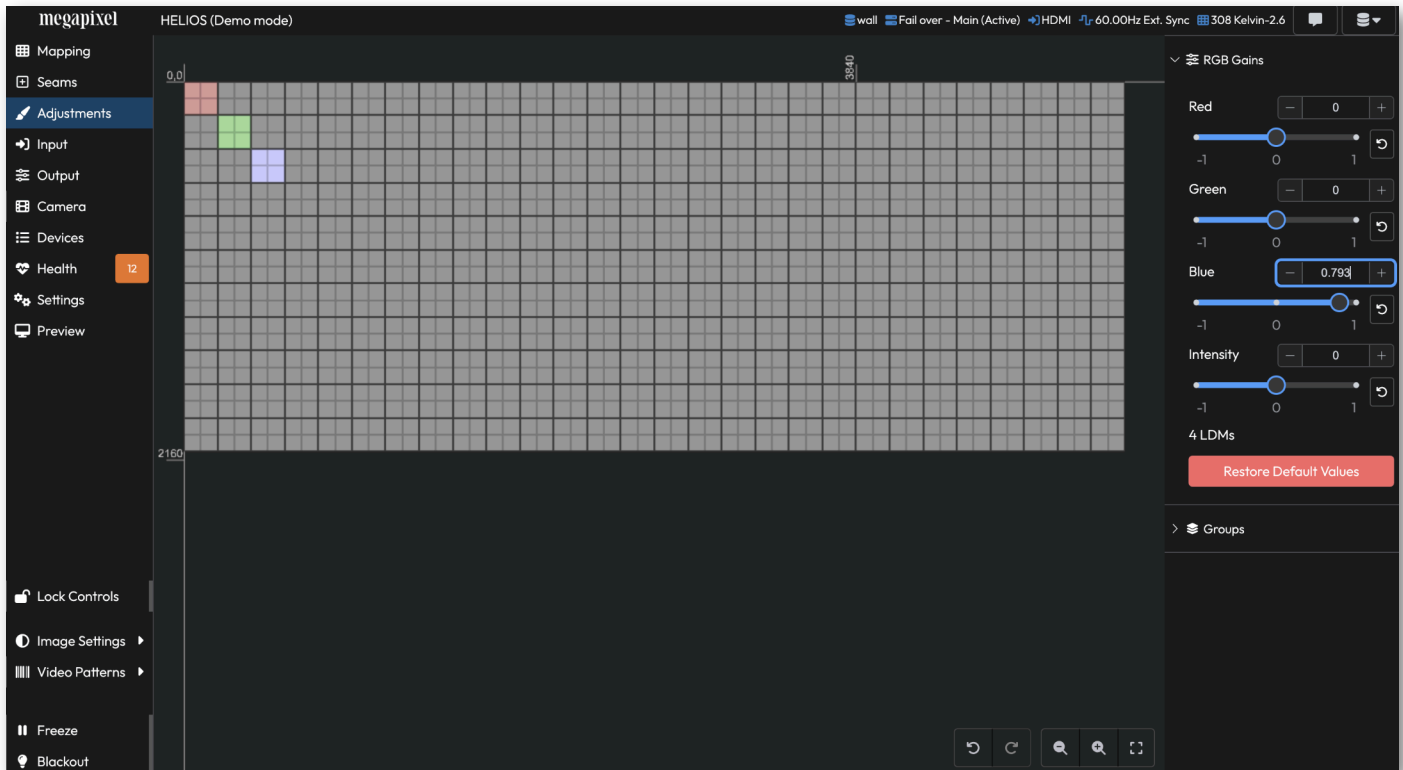

Figure 196: RGB gains Adjustments pane

NOTE: RGB gains adjustments are saved to the tiles. If tiles are sent a reboot command immediately after RGB gains adjustment, HELIOS® will delay the tile reboot by a few seconds to ensure the tiles have saved these changes.

A - Maintenance

A.1 General Maintenance

Proper maintenance of the HELIOS® involves periodically checking the hardware for any parts that are loose or become damaged. Connectors should be checked and the unit replaced if housings are damaged or pins are bent or deformed.

A.2 Processor Filter Maintenance

The front filter on the air intake ducts of the HELIOS® should be periodically cleaned. Gently pry the foam filter out and clean or replace the filters.

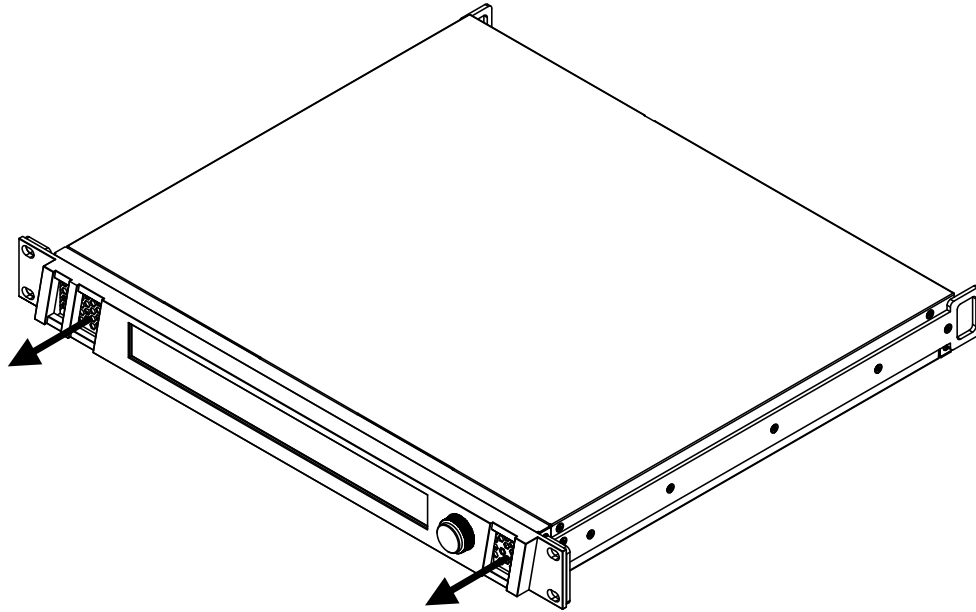

Figure 197: Remove air intake fan filters for service

A.3 Processor Fuse Replacement

The HELIOS® has two (2) glass 6.3A 250VAC 5 x 20mm slow-blow fuses at the power inlet. They are available at common electronics distributors such as [DigiKey](#). To replace these, use a small flat-head screwdriver to gently pry loose the fuse tray. Slide the tray out to the limit. Visually examine the fuse and/or perform a continuity test with a multimeter. If a fuse does not have continuity between the two ends, replace it. If blown fuses are a persistent issue, return the unit to Megapixel for repair.

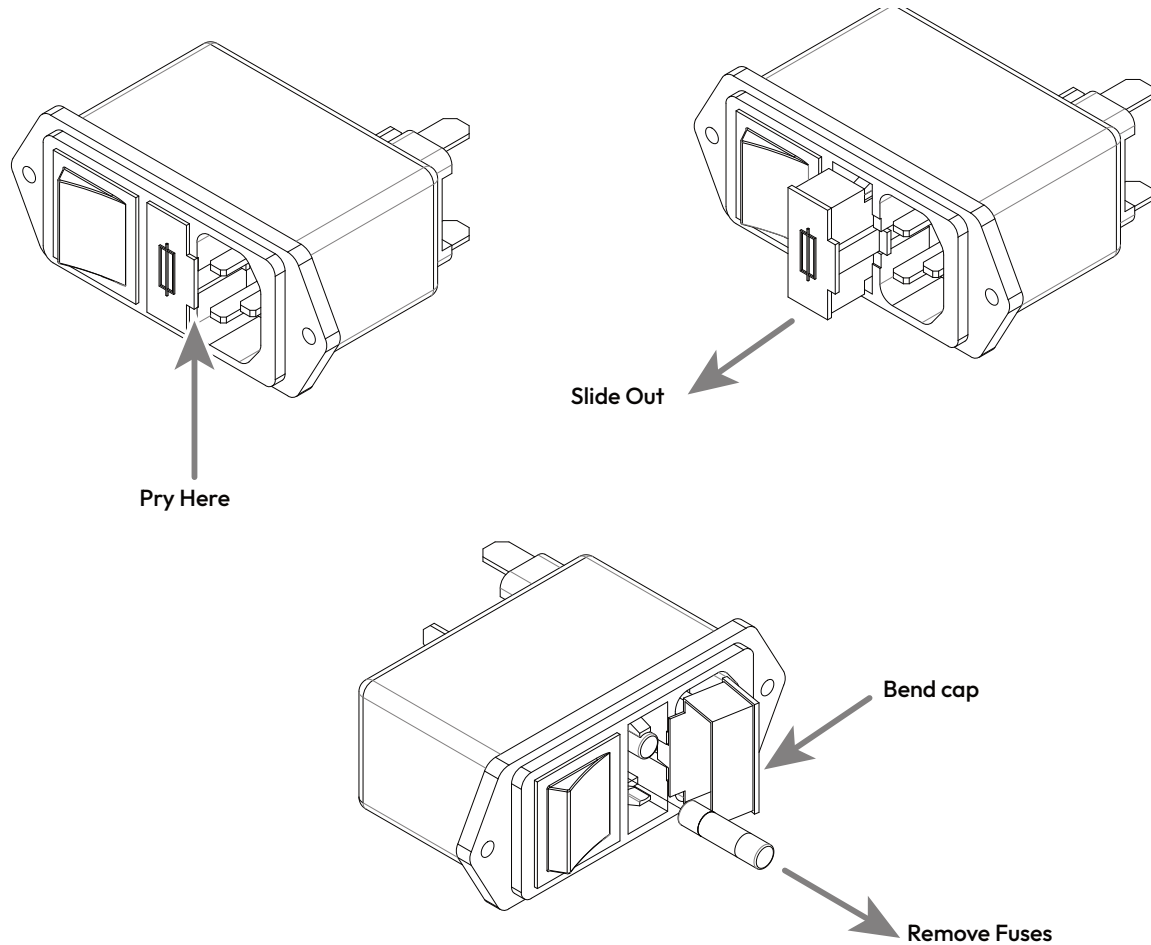

Figure 198: Processor fuse replacement

B - Unknown User / Password

B.1 Overview

When user authentication is enabled, the web UI requires a user and password for access. If the user and password are lost, the only way to regain access is to restore the HELIOS® to factory defaults. When a HELIOS® is restored to factory defaults, all current show information is deleted!

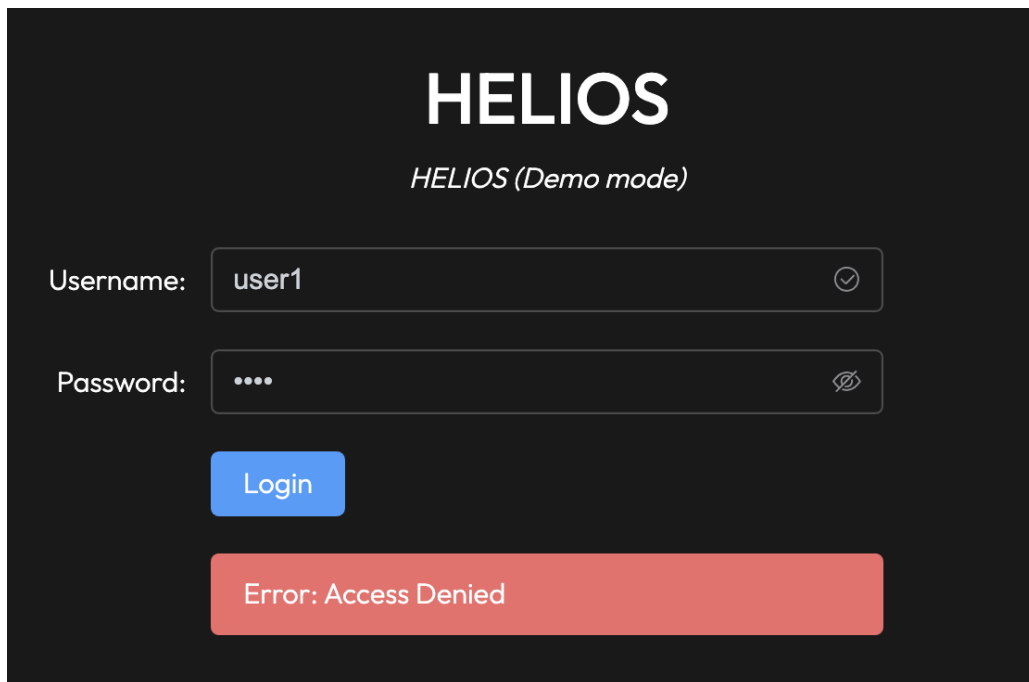
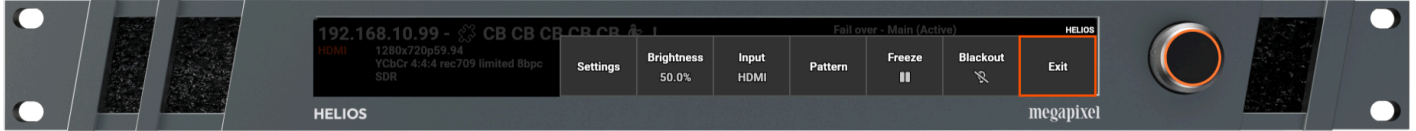

Figure 199: HELIOS® 'Access Denied'

B.2 Restoring to Factory Default

1. Press the encoder on the front of the HELIOS® unit to access the HELIOS® menu.



2. Turn the encoder to select **Settings**.

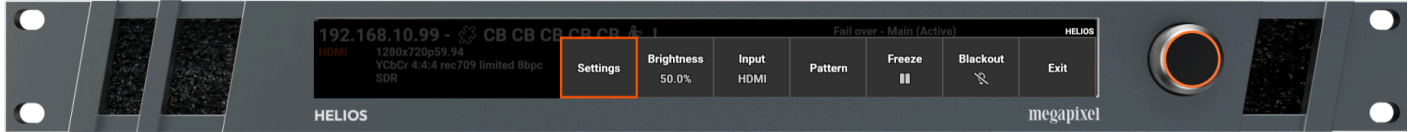

3. Select **Factory Default**.



4. **Confirm** the selection to reset to factory defaults. The HELIOS® will reboot.

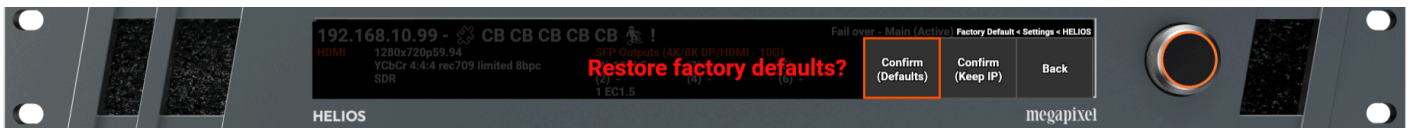

All current show information will be deleted!

C - Troubleshooting Fiber

C.1 Overview

The root causes of fiber connectivity issues are typically related to the fiber cable or the SFP+ units (sending or receiving).

C.2 Troubleshooting checklist:

1. Check for fiber link activity lights. HELIOS® units have a row of fiber connectivity indicators across the middle of the sending SFP+ group (orange rectangle above). If there is activity on these indicators, the fiber is connected.



2. Check the HELIOS® UI for reported signal loss. The **SFP TX** value must be no lower than -9 dBm. The example below shows a -11.8 dBm transmit signal. This is below the minimum -9 dBm required. Also check for any network related error messages on the **Health** pane.

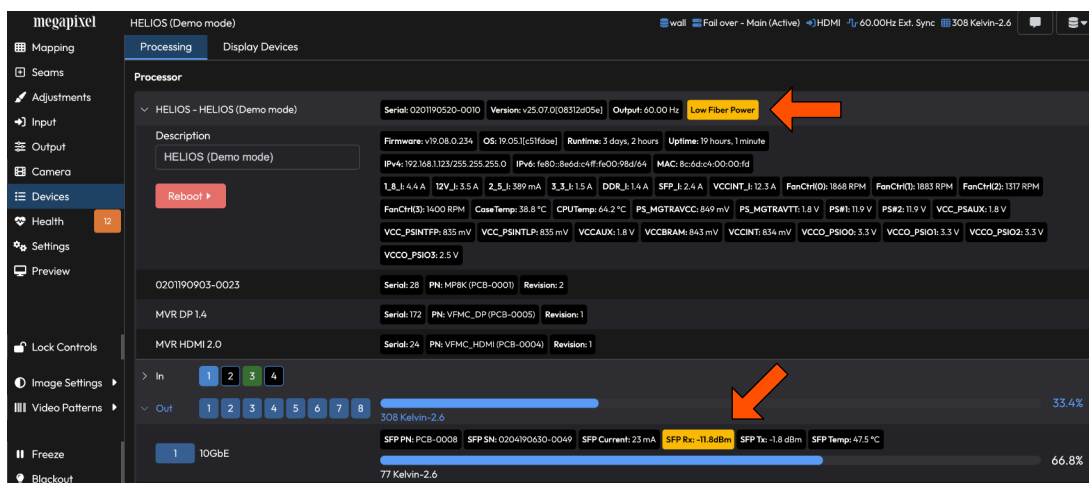

3. Swap the connection for a different fiber strand or cable.
4. Verify fiber type is correct. It should be single mode fiber, 'OS1' or 'OS2'.
5. Confirm correct SFP+ units are being used on each end. Fiber connectivity between the HELIOS® and the network switches require unique Megapixel branded SFP+ units. HELIOS® units have sending SFP+ units, network switches have receiving SFP+ units.

C.3 SFP+ Types

Sending SFP+ — Blue bale clasp, labeled with arrows pointed away from the HELIOS® (top example).

Receiving SFP+ — Purple bale clasp, labeled with arrows pointed towards the network switch (bottom example).



Figure 200: Send and receive SFP+ units

C.4 Testing SFP+ units

The three strategies below can help diagnose a cable or SFP+ issue.

1. Setup the network switch near HELIOS®, and connect a known good, short fiber cable, and test the link.
2. Remove the purple SFP+ from a network switch and move it to an available HELIOS® SFP+ output slot. Use a known good, short fiber cable to link the purple SFP+ with the blue SFP+. If the SFP+ units link successfully, they are good. The issue is likely related to the fiber cable itself.
3. Remove a blue SFP+ from a HELIOS® output slot and move it to an available SFP slot on a network switch. Connect a known good, short fiber cable between the two SFP+ units and check for link. If the SFP+ units link successfully, the issue is likely related to the fiber cable itself.
4. If an SFP+ fails this test, it will need to be returned for replacement. Please contact Megapixel support for further instructions.

NOTE: The above can only be done using different models of SFP+ (purple and blue). Fiber systems cannot link two (2) sending units or two (2) receiving units.

C.5 Incompatible SFP Alert

HELIOS® units must be properly licensed for the SFP modules in use. The standard license allows 1G copper if set to **HELIOS® Jr.** operating mode or 10G fiber if set to **HELIOS® Standard** operating mode, whereas the junior license only allows 1G copper and will have standard mode grayed out in the selection drop-down. Mismatched licenses and SFP modules will generate system health alerts.

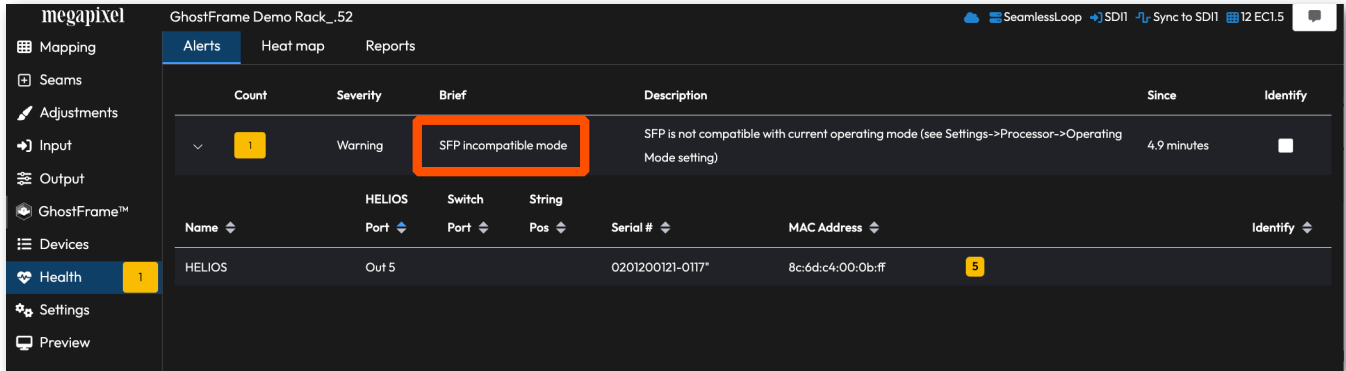

Figure 201: Incompatible SFP

C.6 Troubleshooting License Checklist:

1. Check the system **Settings > Processor Settings > Licensing** for the license type. A **HELIOS® Standard** license enables both copper and fiber SFP+ modules, whereas a **HELIOS® Jr.** license only enables copper SFP modules.

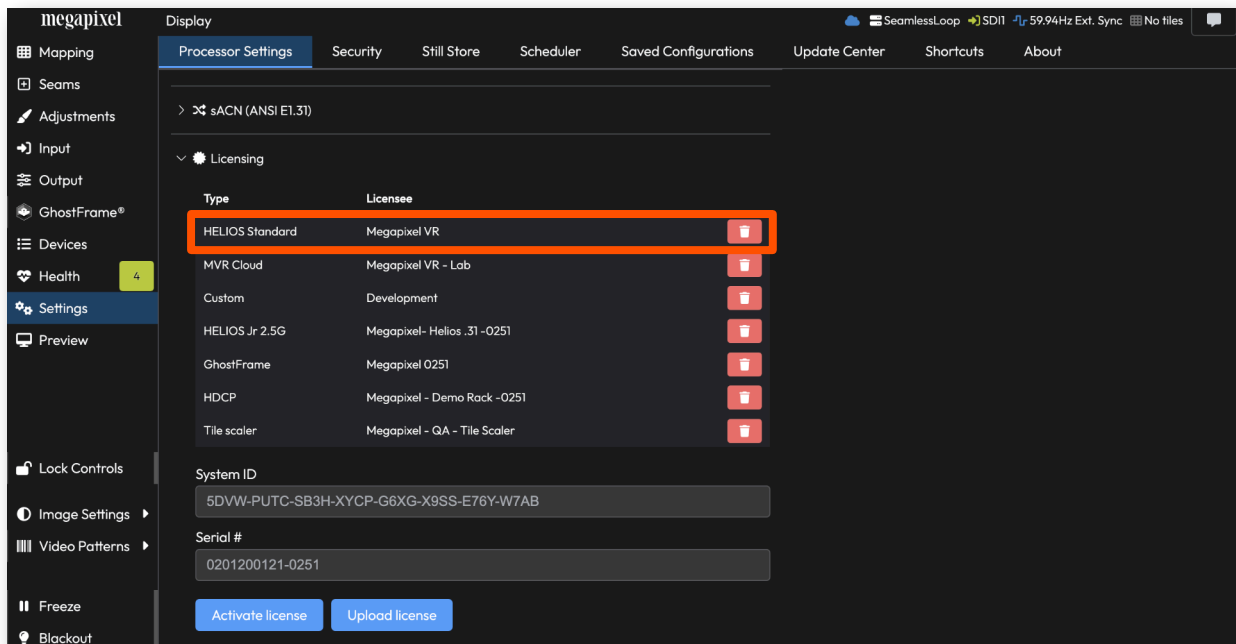

Figure 202: HELIOS® Standard license

C.6 Troubleshooting License Checklist:

2. Check the operating mode in system settings. A **HELIOS® Jr.** license will only operate Junior mode.

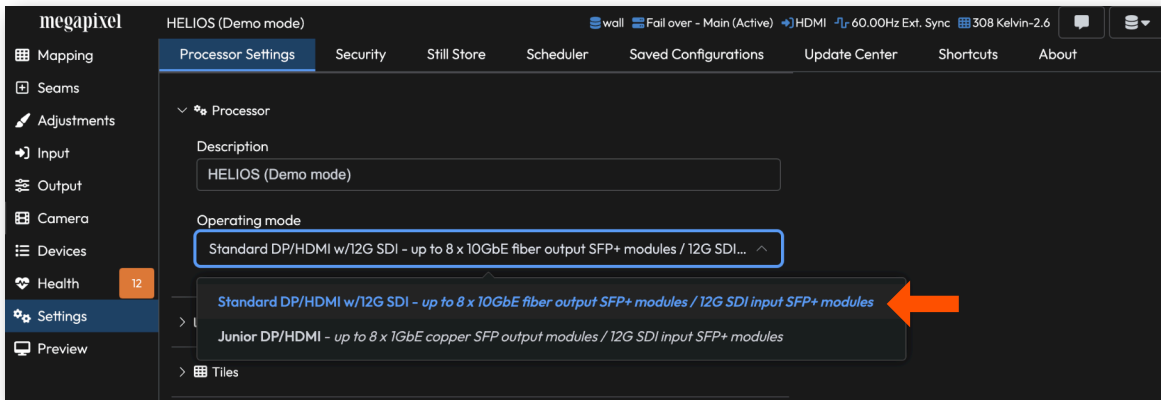

Figure 203: Check operating mode

3. Check the type of SFP modules and in which ports they are installed in the **Devices** pane. The image below shows the error a **HELIOS® Standard** system will generate with a copper SFP installed in port 4. Copper SFP modules are only compatible with **HELIOS® Jr.** mode. If copper SFP module(s) are needed, the user should switch to **HELIOS® Jr.** mode (in Processor Settings). A **HELIOS® Standard** license can operate in both **HELIOS® Jr.** and **HELIOS® Standard** modes.

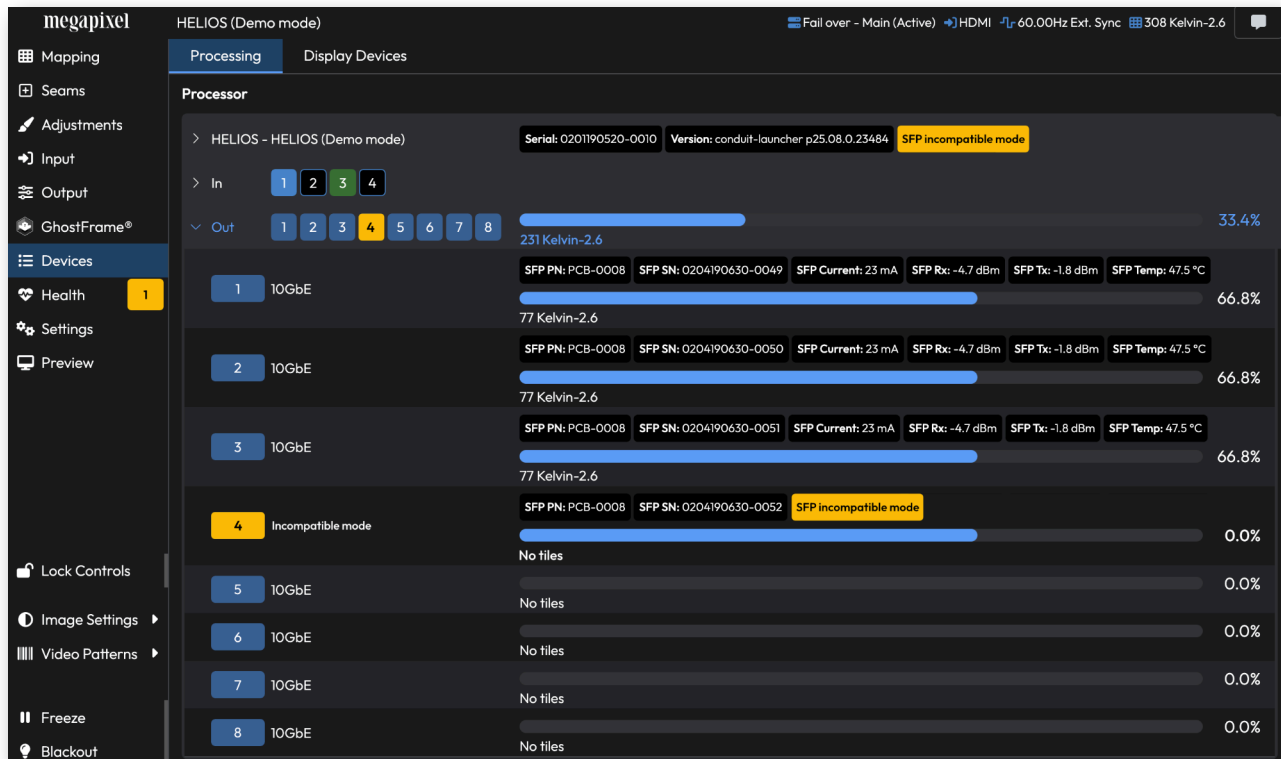

Figure 204: Incompatible copper SFP+ modules with the HELIOS® mode

D - Low Level Noise Reduction

D.1 Overview

This section describes what Megapixel has found to be the most effective method for reducing low level video noise on LED displays.

Below are two images of an LED display with a dark field next to a person. The image on the left is an example of low level noise that needs to be removed (the errors in black have been exaggerated for illustrative purposes). The black region to the left of the person shows several blocks of different degrees of black. After the adjustments in HELIOS®, the image on the right shows fewer irregularities in the black region next to the person.

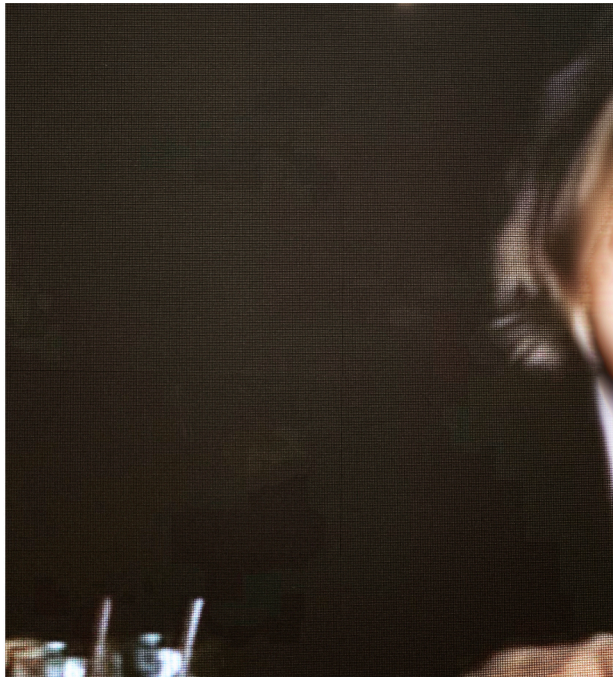

Before

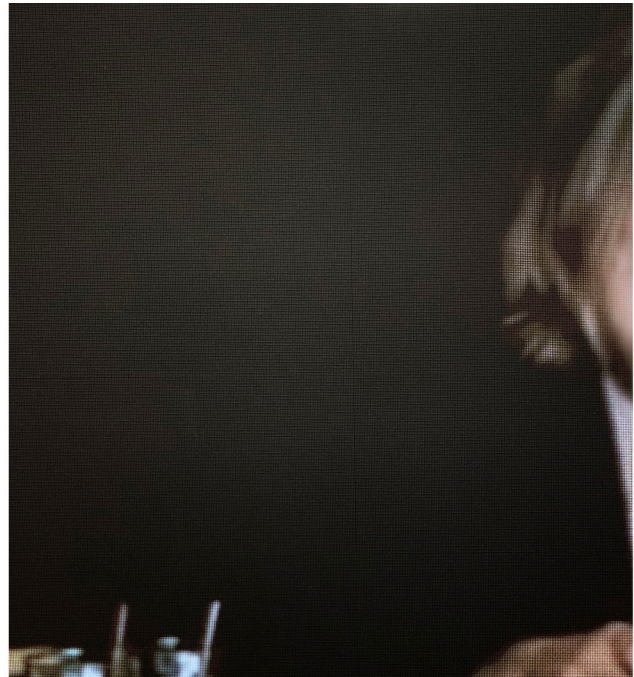

After

Figure 205: Before and after correction

D.2 Low Level Noise Reduction Steps

1. Ensure that the content is as noise-free as possible before it is sent to HELIOS®.
2. Enable Advanced Mode in **Settings > Processor Settings**.

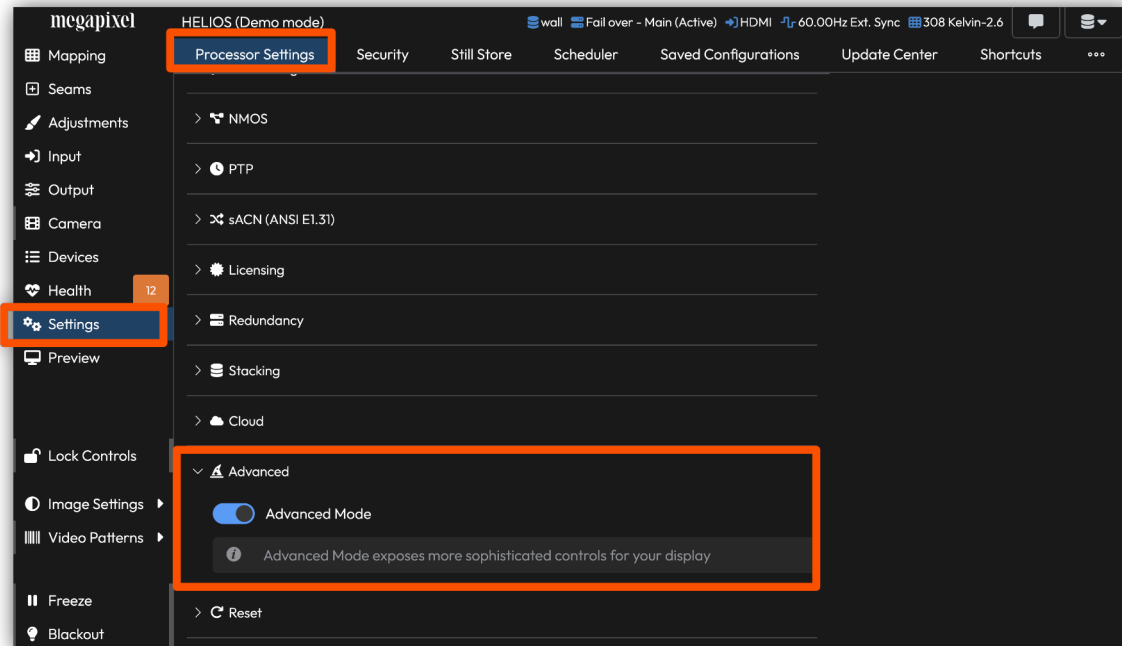

Figure 206: Advanced Mode

3. Navigate to the **Output** pane > **Output adjustments** accordion and increase the **Black clipping** value.

Black clipping - raises the floor for the value to be considered black. This causes a loss of detail in shadows and other dark content regions as values below the threshold are not displayed.

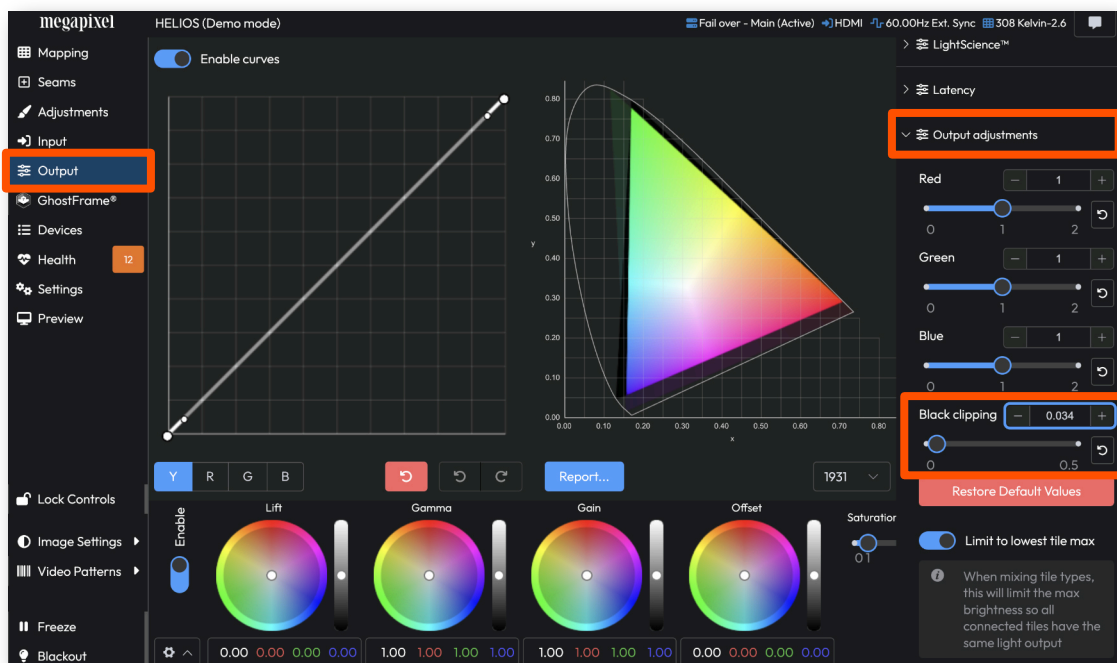

Figure 207: Output adjustments

D.2 Low Level Noise Reduction Steps

4. Navigate to the **Input** pane > **Input adjustments** > **Black Level** slider control to reduce the inbound noise by raising the black level.



Figure 208: Input black Level

E - Content to Panel Luminance Curves

E.1 Overview

PQ encoded HDR content reports a luminance range for the content in the metadata of the HDMI or SDI signal. This section covers how HELIOS® handles this luminance data to maximize the capabilities of panels.

The various colored dots on the chart below represent scenarios where panels of different luminance capabilities are matched with content mastered to narrow, medium, and wide range luminance. The far right side cyan dots represent the luminance curve supplied by the PQ content. Each of the 'tile to content' scenarios is mapped against this 0 - 10,000L range.

The blue dot scenario in the graph below shows a panel with a maxL of 100 receiving content mastered with a maxL of 100. The max content level is 100, and the panel is 100. The panel is capable of showing the full range of content (0-100). An image being reproduced in this manner displays the image as artistically intended.

The red dot scenario shows the same 100 maxL panel receiving content mastered to a wider range of 1,000L. The graph shows a more rounded curve as the image loses some of the high level details and the panel is unable to reach the intended brightness levels. The same holds true with the yellow dot scenario, in which a low luminance panel (100L) is given a very wide luminance range. In this case, the slope is even more pronounced as the panel limitations don't allow for the accurate reproduction of the content.

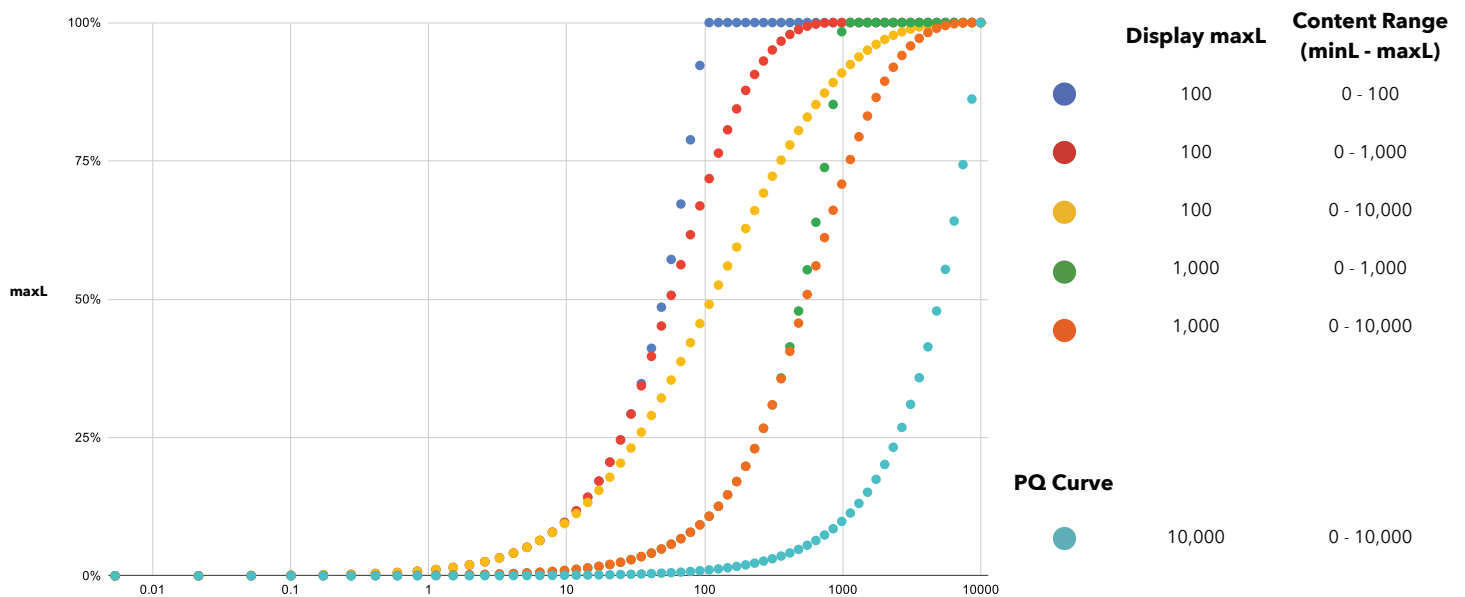

Figure 209: HELIOS® EOTF luminance curves

The image below is a graph of a scenario where 500 nit content is not being displayed correctly on a 100 nit display. As HELIOS® has been configured to expect content mastered at 100 nits, while the inbound signal actually has a max content level of 500 nits. Red dots are the content, blue is what actually happens on the display. All of the information above 100% is being clipped by the display.

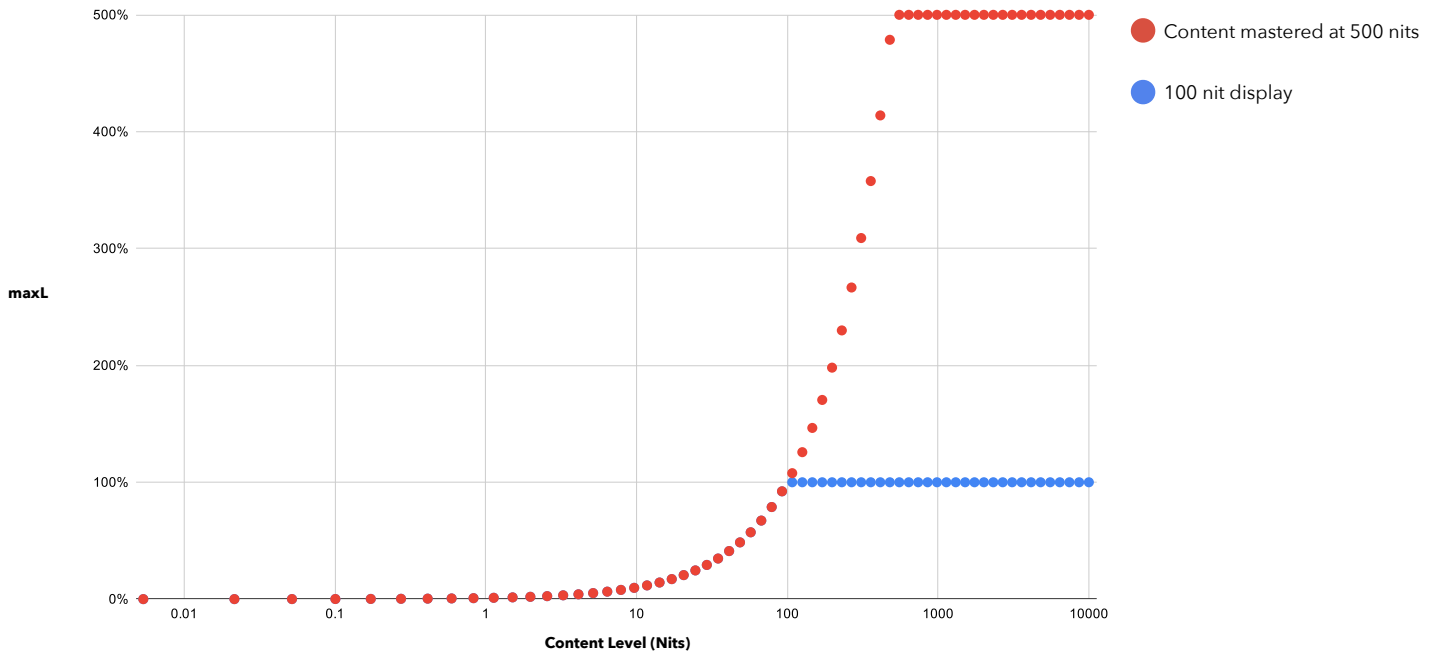

Figure 210: Incorrectly configured content

It is best practice to align the luminance range of the content to that of the panels. As a workaround for when the content is not mastered for the display, the HELIOS® EOTF overrides can be used to ‘boost’ the display’s brightness, but will have the side effect of lowering the overall output brightness. An alternative is to adjust the content levels, but that risks clipping content highlights.

NOTE: In cases where the content doesn't advertise a content **MaxL**, HELIOS® uses the **MaxL** of the display.

Content should always be intentionally mastered at a MaxL matching the final display's nit level. In the real world, however, it is quite common for content to be delivered at a default of 1000L. Below are a series of images showing how correct vs incorrect metadata can greatly increase or decrease detail and fidelity. Note the detail of the buildings outside the window are lost. This is due to a Display MaxL of 100 with Content MaxL defaulting to 100L due to a lack of metadata in the video signal. The actual content was mastered for 1000L, so all levels above 100L will lose detail.



Figure 211: Detail lost

In the second image, the Content MaxL has been overridden to 1000 nits to match how the actual content file was mastered. Notice the significant increase in detail in the buildings outside the window.



Figure 212: Detail retained

F - Data Redundancy

F.1 Overview

The HELIOS® system supports multiple high availability redundancy modes. Redundancy is accomplished by sending simultaneous, bidirectional video data to each end of tile strings. There are several different system topologies possible with varying degrees of redundancy. The following sections illustrate the supported system topologies.

NOTE: To support the latest HELIOS® redundancy features, tiles must have software version 23.12 or later before the system is cabled into a redundancy mode. M4250 switches need to be updated to 13.0.4.18+ (branch A) or 13.9.7.23+ (branch B). See the end of this section for the software upgrade process.

F.2 Seamless Redundancy

Multiple HELIOS® feed multiple switches. The most complete type of redundant system. All of the HELIOS® processors must be connected to the same video feed and to an external genlock sync.

Item	Redundancy
HELIOS®	✓
Fiber Cables	✓
Network Switches RS12 M4200 M4250	✓
Ethernet Cables	✓

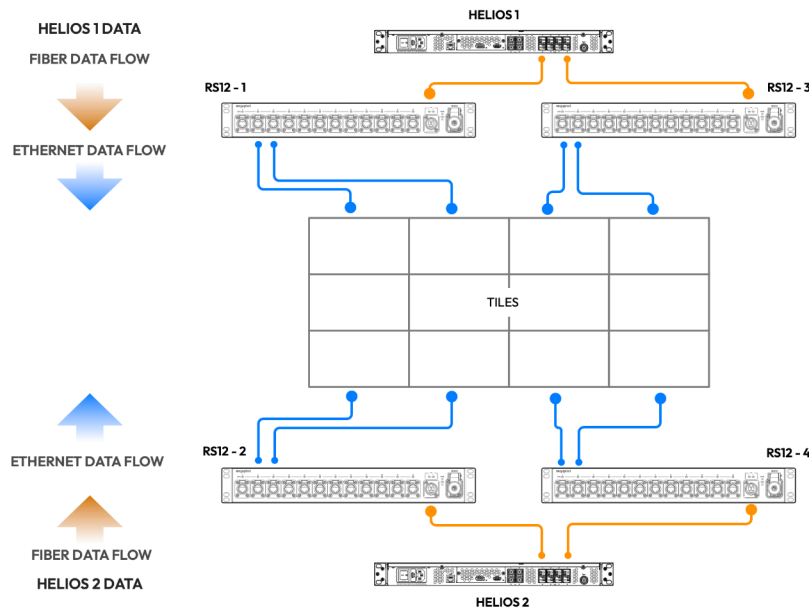

Figure 213: Full redundancy system example

F.3 Seamless Loop™ - HELIOS® Jr. Redundancy

The HELIOS® Jr. via copper SFPs sends tile data out of multiple ports. There are no switches used in this type of system.

Item	Redundancy
HELIOS®	✗
Fiber Cables	N/A*
Network Switches	N/A*
Ethernet Cables	✓

*Since HELIOS® JR. are not fitted with fiber SFPs, switches are not used.

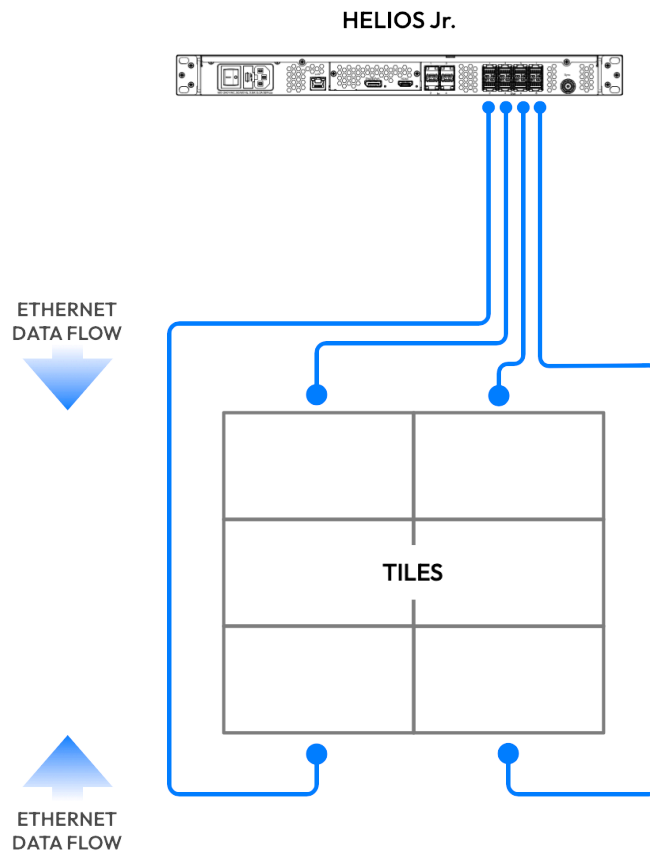

Figure 214: HELIOS® Jr. redundancy example

F.4 Seamless Loop™ - Tile Link Redundancy

Multiple outputs of a switch send bidirectional data to tiles.

Item	Redundancy
HELIOS®	✗
Fiber Cables	✗
Network Switches	✗
Ethernet Cables	✓

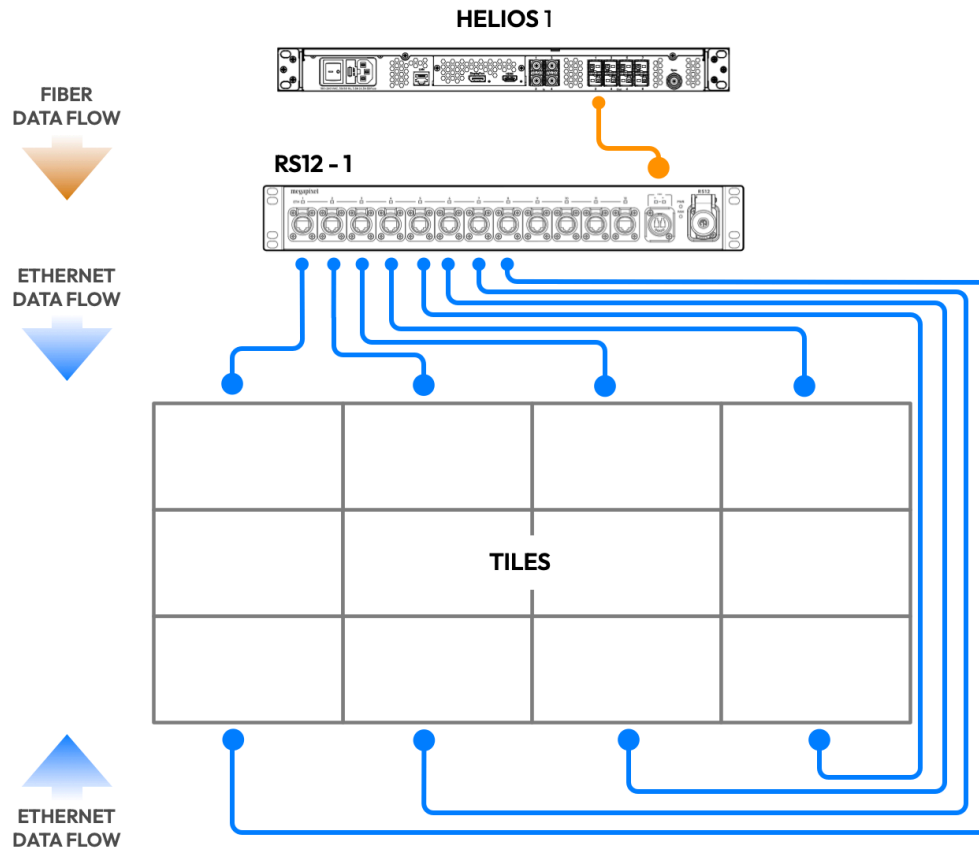

Figure 215: Tile link redundancy example

F.5 Seamless Loop™ - Switch Redundancy

One HELIOS® uses multiple fiber ports to feed redundant switches.

Item	Redundancy
HELIOS®	✗
Fiber Cables	✓
Network Switches RS12 M4200 M4250	✓
Ethernet Cables	✓

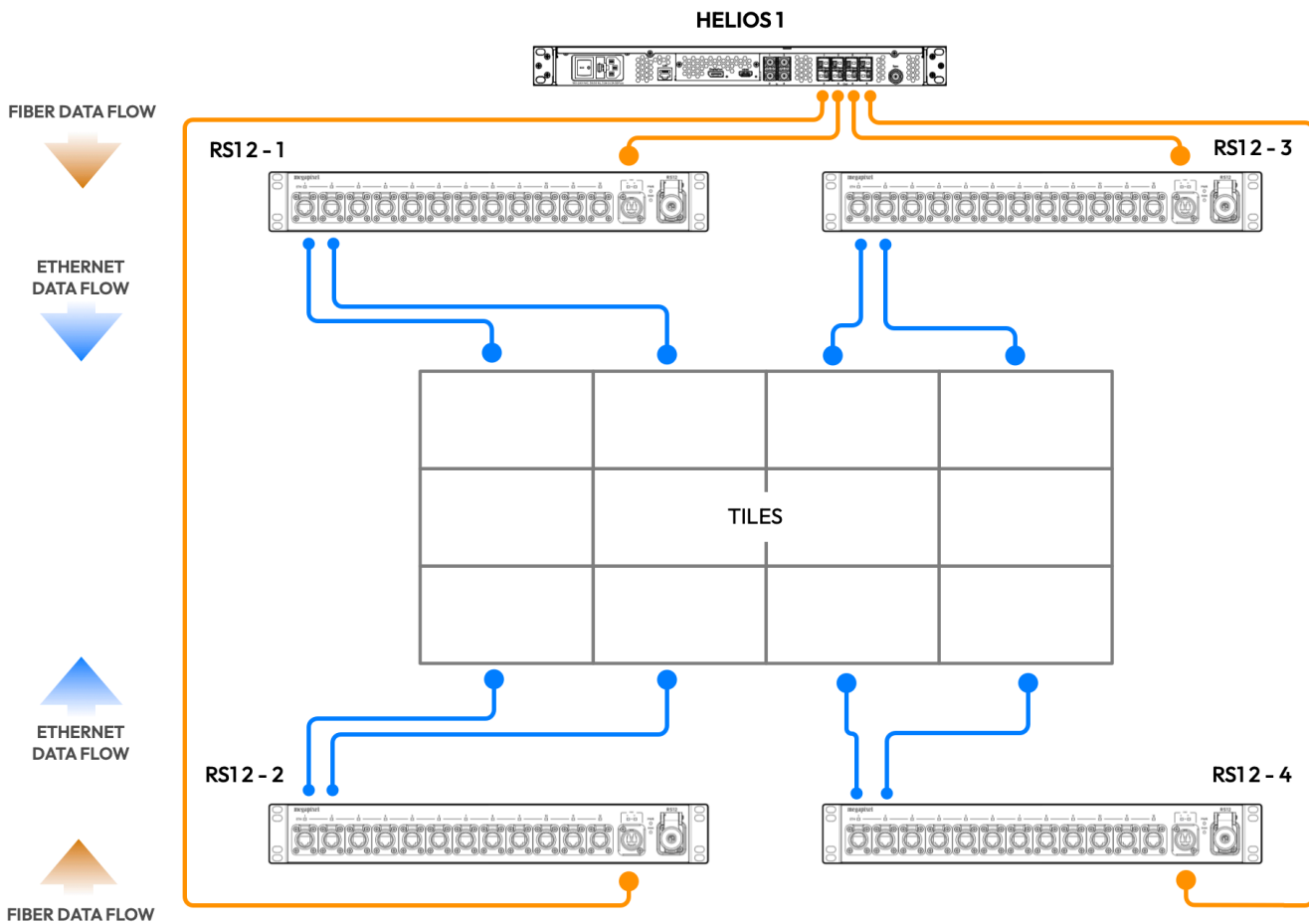

Figure 216: Switch redundancy example

F.6 Redundancy Settings

Redundancy is enabled by physically configuring the system in any of the supported redundancy schemes as shown on the previous pages. In the user interface, ensure the **Advanced Mode** is ON (**Settings > Processor Settings > Advanced**). The redundancy controls are located under **Settings > Processor Settings**.

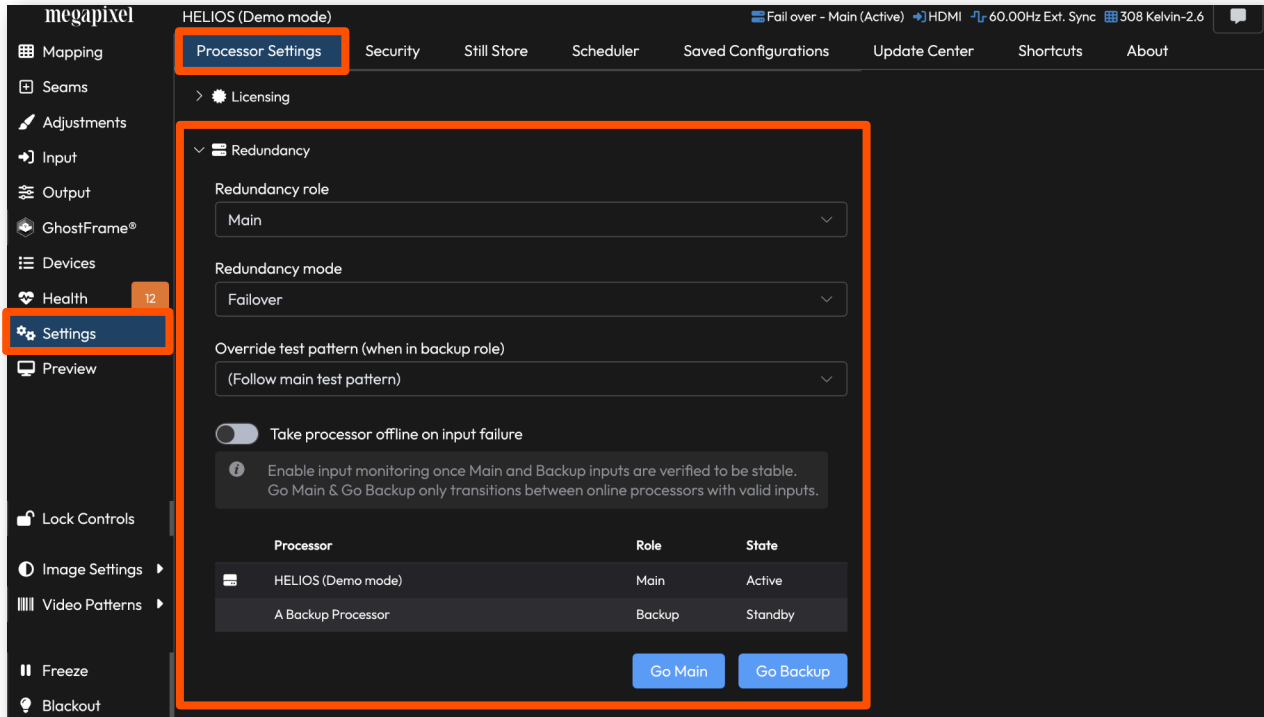

Figure 217: Redundancy settings

F.7 Processor Role

The role selection lets the system know how a processor should be prioritized in the system.

HELIOS® has three options:

Main (default) — Selecting this role identifies the processor as the primary processor in the system.

Backup — Identifies the processor as the redundant unit to be used in case of an issue with the Main processor.

Offline — Identifies the processor as not available to the system. This is the role to use when a known issue has occurred with a processor. The HELIOS® system will ignore a processor in this role.

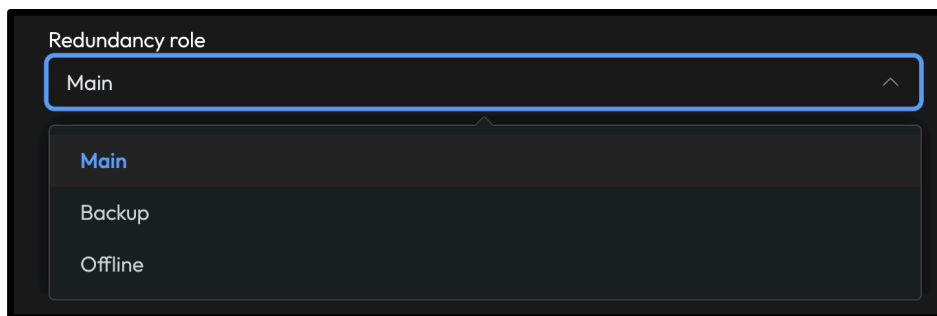

Figure 218: Role options

F.8 Redundancy Modes

One of the operating modes must also be selected.

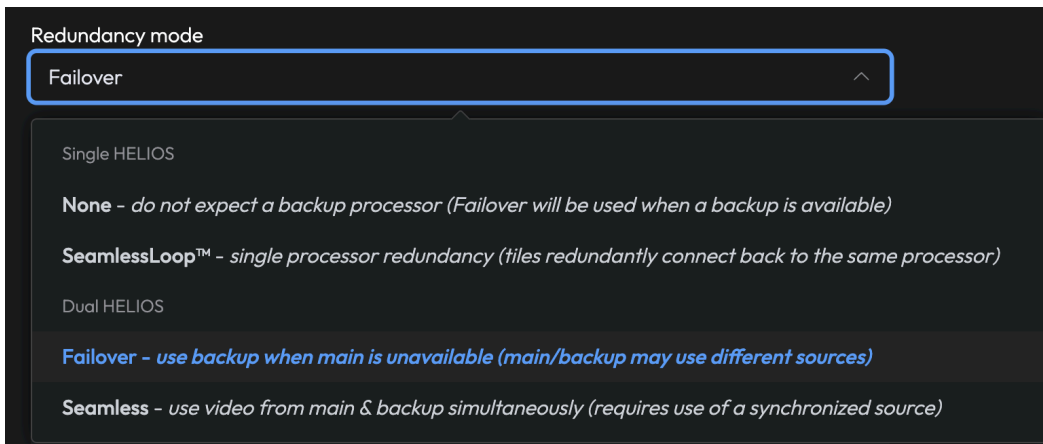

Figure 219: Mode selection

Single HELIOS®

None — HELIOS® will not be expecting a backup processor. If the backup processor goes away HELIOS® will not throw any errors. If HELIOS® detects a backup processor on the network it will still be able to make use of it.

Seamless Loop™ — Tiles receive duplicate data from the same HELIOS®.

Dual HELIOS®

Failover — Tiles are set to receive video from one processor only, the main processor. This provides tiles with a predictable signal path. Tiles will re-associate to the backup processor if the main processor stops sending video or the input fails. Since tiles only accept video from one processor, a failure event will have a slight perceptible disruption in the content as the affected tiles associate with the backup processor.

Seamless — Tiles are automatically associated with the highest priority processor available to them during startup. In this mode, the tiles in the display are allowed to receive video simultaneously from both processors. The image that a tile displays can be made up of data from both the main and backup processor. When using the **Seamless** mode, the input video to each of these HELIOS® must be identical and frame synced. This is so that there will be no perceptible difference in the image, as tiles use data from both processors. Since the system is using both processors simultaneously, failures have a near imperceptible impact. However, **Seamless** mode may not reliably detect input failures in complex upstream video pipelines.

F.9 Override test pattern (when in backup role)

An alternate processor test pattern can be assigned to backup processors. This feature is primarily designed to help technicians during setup see clearly which processor a tile is currently connected to. The default mode is to follow the main test pattern (the first option in the list). When in **Seamless Loop™** redundancy mode, override test pattern will still honor the main/backup role, but the system can no longer flip between roles, since there is only one processor.

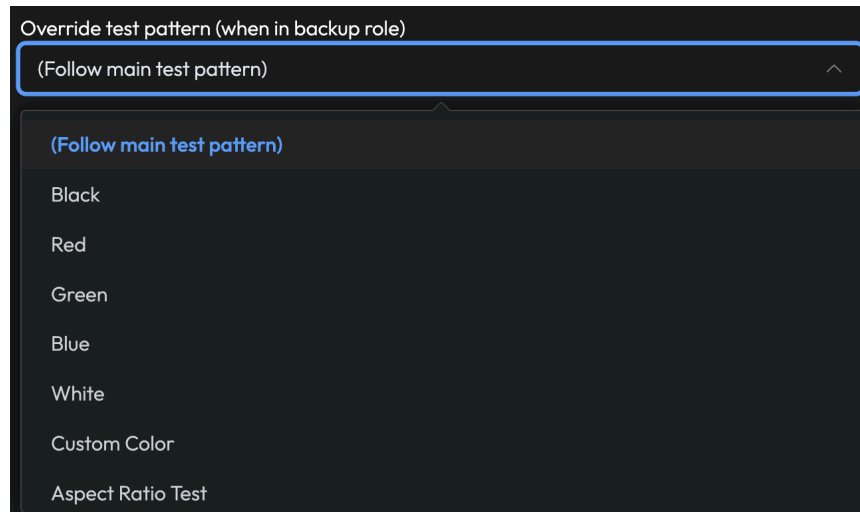

Figure 220: Test pattern override

F.10 Take processor offline on input failure

Should the input on the main processor fail to receive frames, the system will switch to a processor with a functional input. In the case of stitched inputs (dual DP/HDMI and quad SDI) losing one of the input links will make that entire input be considered invalid and will trigger a switch. If this toggle is left off, input failure is not used as a criteria to switch processors. Displays will show black until inbound frames are restored to the processor.

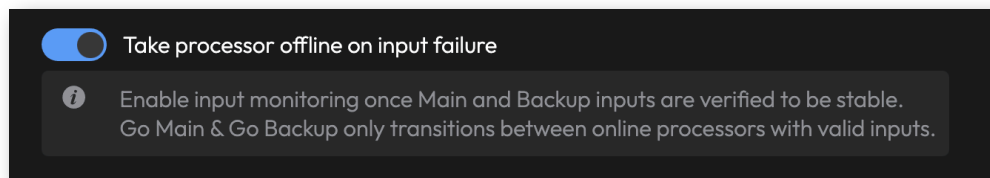

Figure 221: Take processor offline toggle

NOTE: When **Take processor offline on input failure** is toggled ON, HELIOS® will not allow the user to **Go Main** (see below) a processor with no input.

F.11 Redundancy States

Active — Processors are **Active** when all the panels are connected to only that processor.

Mixed — A **Mixed** state occurs when some tiles are using a different primary HELIOS® (likely caused by a failure). This is most often caused by an unplugged or damaged cable in the data route. Ideally, the tiles in a system should all be connected to either the **Main** or the **Backup** processor. Once the issues with the data route have been solved, use the **Go Main** or **Go Backup** buttons to associate all the tiles with the **Main** processor or the **Backup** processor.

Standby — Processors are in **Standby** when no panels are connected.

Offline — A Processor is considered **Offline**, either via explicit role selection or through input failure.

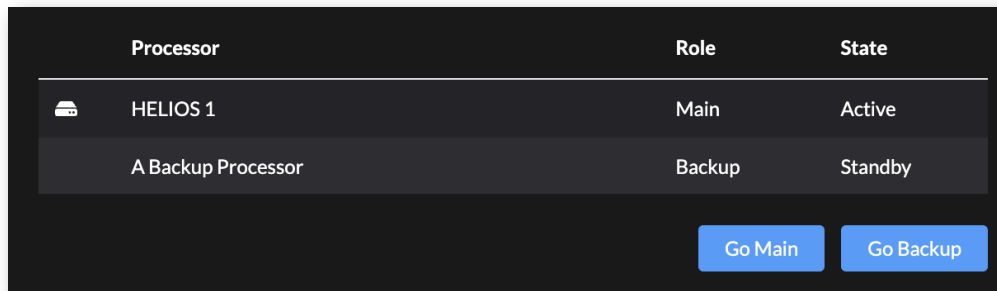

Processor	Role	State
 HELIOS 1	Main	Active
A Backup Processor	Backup	Standby

Go Main Go Backup

Figure 222: Processor Roles and States

F.12 Manual Overrides

If both processors have equal priority on startup, tiles will associate with the first processor they see. If the results of the automatic tile to processor association are not what the display operator needs, a manual **Go Main** or **Go Backup** command can be sent to re-associate the tiles to the desired processor. **Go main / Go backup** are not available in systems that use only one HELIOS® processor.

Go Main — A manual override command to tiles. When this command is issued, tiles will associate to the **Main** processor.

Go Backup — A manual override command to tiles. When this command is issued, tiles associate to the **Backup** processor.

F.13 Redundant System Status Indicator

When HELIOS® is running as a redundant system, the UI will show a status color on the redundant system icon at the top bar of the UI.

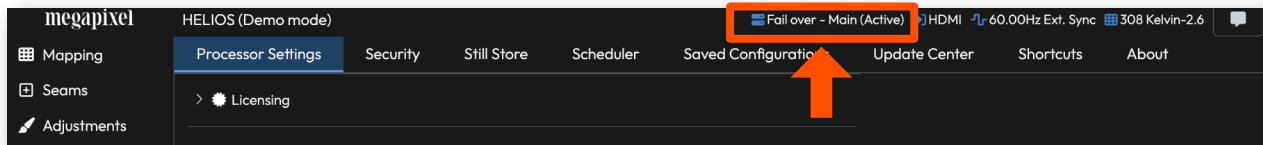
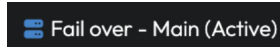
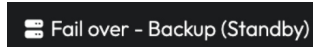

Figure 223: Failover status

Blue — the processor is set for redundancy, all tiles are connected to the processor, and a backup processor is in place.



White — the system is set for redundancy, and this processor is the backup system. If a failure occurs, this processor is ready and will take over.



Yellow — indicates that the tiles are in a mixed state. This means that not all tiles are connected to the same processor. While the wall may appear functional, this state should be investigated to determine why tiles are not all connected to a single processor.

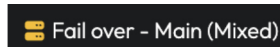

Orange — the system is set for redundancy, but the system is not capable of switching to a redundant backup system. This is most likely due to the backup processor not being detected.

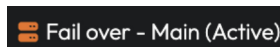

F.14 Processor Stacking

Stacking should be used when configuring a redundant system. When stacking is enabled, (**Settings > Processor Settings > Stacking**) processors share states such as global brightness, tile positions, and redundancy settings (see Appendix K for a [comprehensive list of items tracked by stacking](#)). After enabling stacking, enter a stack name to join. If another processor is found with the same stack name, a blue dot icon shows up in the list next to the IP address indicating that the processor has joined the stack.

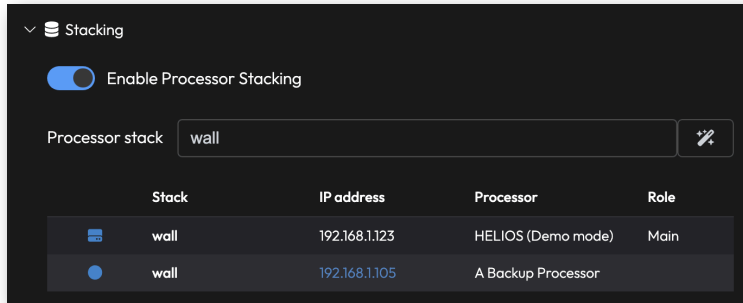

Figure 224: Stacking settings

NOTE: Let stacking take care of sharing data from one processor to another. Do not manually transfer saved configurations from one stacked processor to another. Stack processors before mapping tiles. Alternatively, create the stack with the primary processor first. The order in which processors join a stack matters! Settings are propagated based on how long processors have been part of the stack. Newly added processors will copy the settings from the existing processor. If stacking is done in the wrong order, without a saved configuration, settings will be lost.

F.15 Front Panel Redundancy Info

When redundancy is enabled, the top right of the HELIOS® front panel display reports the redundancy **Mode**, **Role**, **State** and **Stack name**. The example below is set to **Failover** mode. Possible modes are: **Failover**, **Seamless Loop™** and **Seamless**. The example below is set to the **Main** role and **(Active)** state. Possible states are **Active**, **Standby** and **Mixed** (cases where tiles are split between the main and backup processors). Below the **Mode**, **Role**, and **State** info the HELIOS® reports the stack it has joined (as set by the Stacking settings). In the example below, the stack that the HELIOS® has joined is called **MyStackGroup**. When redundancy is not enabled, only the stack name will be displayed.



Figure 225: Front UI redundancy info

F.16 Devices Pane Processing Tab

The **Devices** pane **Processing** tab contains important ‘behind the scenes’ information regarding the redundant data routes. When HELIOS® detects a redundant data route it highlights the switch port (**A** arrow in the example below) and assigns a route number (**B** arrow). In the example below, both switch port **0/2** and **0/12** carry route **1** data. Backup ports are highlighted with a dashed line as port **0/12** shows in the example below. HELIOS® displays dynamic data, the **Devices** tab is always updated with the latest routing data as the HELIOS® becomes aware of the changes in the system topology.

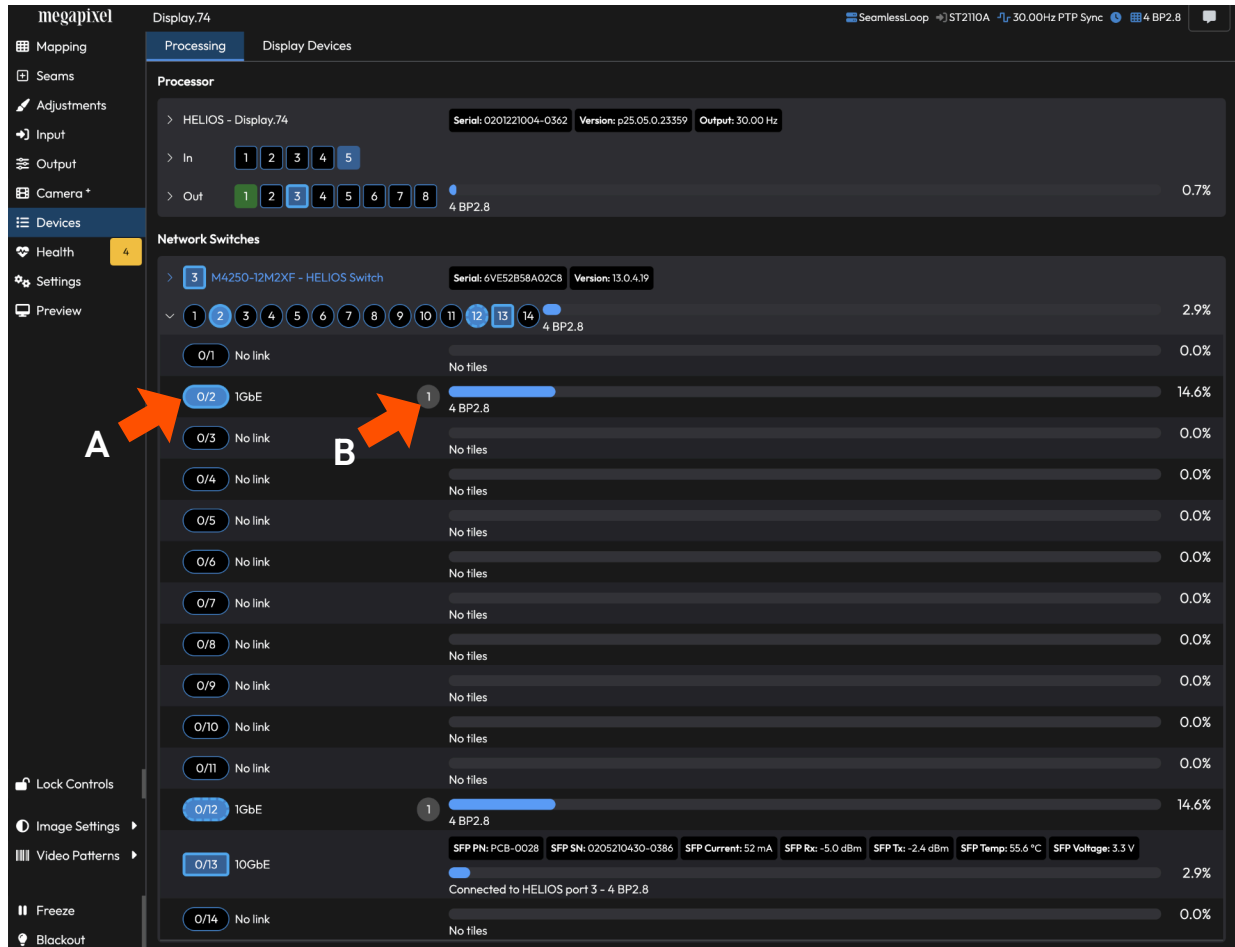

Figure 226: Redundant route info

F.17 Devices Pane Link Icon

The devices pane shows a **link icon** (🔗) next to items connected to the same system as the current web UI. In other words, if the operator is currently controlling the **Main** system while browsing the **Display Devices** tab, all of the tiles connected to the **Main** processor show link icons as in the example below.

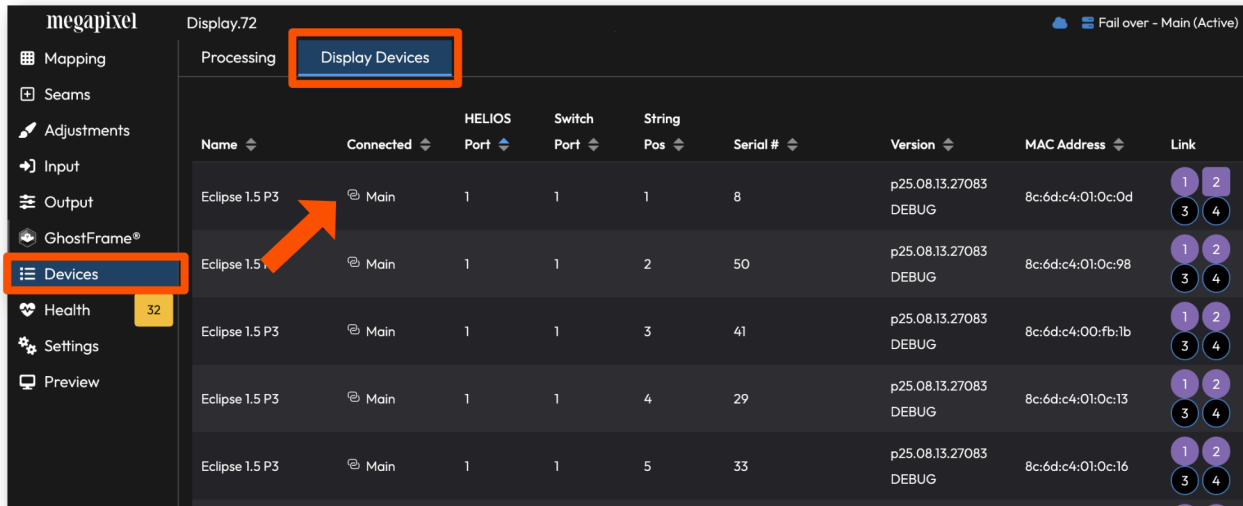

Figure 227: Devices pane link icon

F.18 Software Upgrade Process

Upgrade tiles to version 23.09 or greater using only a single HELIOS®. Please see the Update Center ([Section 5.15](#)) for more details. Tiles need to reply to processors after finishing an upgrade. Having two processors in the system during an upgrade can cause issues with these replies from tiles with earlier firmware versions.

When upgrading a redundant system to a version of HELIOS® and tile firmware that supports redundancy, it is important to follow a specific sequence:

1. Connect HELIOS® MAIN, network switches MAIN, and tiles as normal. Confirm mapping/video as expected.
2. Upgrade the HELIOS® MAIN.
3. Upgrade tiles.
4. Boot up HELIOS® BACKUP and network switches BACKUP (do not connect tiles yet).
5. Upgrade HELIOS® BACKUP.
6. Wait for the network switches BACKUP to appear in devices page.
7. Connect tiles to the network switches BACKUP.
8. Activate stacking and configure redundancy options.

F.19 Troubleshooting Failover Mode Redundant Systems

Systems running in **Failover** mode are only sending one stream of data to the tiles at a time. So, there are fewer requirements to synchronize the data. Below are some steps to follow if a system running in **Failover** mode is having issues.

1. Start over. Meaning, treat the system as a new display. A HELIOS® factory default reset (**Settings > Processor Settings > Reset**) may be a good idea if there is any uncertainty about the HELIOS® settings.
2. Enable stacking on both processors and make sure they are in the same stack group.
3. Select the **Mapping** pane and confirm that the tiles are mapped correctly for the way they are physically cabled.
4. Select the **Input** pane. Check the video input is set to the correct one for the system and the details (resolution, frequency, etc.) are as expected.
5. Still in the **Input** pane, ensure the size of the output window is the same on both HELIOS® processors.

F.20 Troubleshooting Seamless Mode Redundant Systems

Systems running in **Seamless** mode are sending two (2), simultaneous, synchronized streams of data to the tiles. So, there are more requirements to synchronize the data. Below are some steps to follow if a system running in **Seamless** mode is having issues.

1. Start over. Meaning, treat the system as a new display. A HELIOS® factory default reset (**Settings > Processor Settings > Reset**) may be a good idea if there is any uncertainty about the HELIOS® settings.
2. Enable stacking on both processors and make sure they are in the same stack group.
3. Select the **Mapping** pane and check that the tiles are mapped correctly for the way they are physically cabled.
4. Select the **Input** pane. Check the video input is set to the correct one for the system and the details (resolution, frequency, etc.) are as expected. Always use the same input type on each HELIOS®. If the main HELIOS® is receiving the input signal on DisplayPort, the redundant HELIOS® must be receiving on DisplayPort input as well.
5. Still in the **Input** pane, ensure the size of the output window is the same on both HELIOS® processors.
6. Use an external sync. Ensure each HELIOS® is receiving an external sync (Genlock or PTP).
7. Enable **Take processor offline on input failure** under **Settings > Processor Settings > Redundancy**. See previous section ([F.10](#)).

G - ST 2110

G.1 Overview

ST 2110 is a suite of standards developed by the Society of Motion Picture and Television Engineers (SMPTE) for transmitting professional media over an IP network. The standards describe how video, audio, and metadata should be packaged and transported over an IP network. ST 2110 is designed to work with existing IP network infrastructure and to be scalable with future advances in IP-based technologies.

In the following examples only the minimum components for sending ST 2110 to HELIOS® are shown. Actual system implementations usually have additional signal routing equipment.

The example below illustrates an ST 2110 signal being sent to HELIOS® from a native SDI camera through an ST 2110 gateway device. Separately, a PTP (Precision Time Protocol) Generator device provides sync through the switch to HELIOS® and the ST 2110 Gateway. HELIOS® supports the SMPTE ST 2059 (2021 edition) PTP profile.

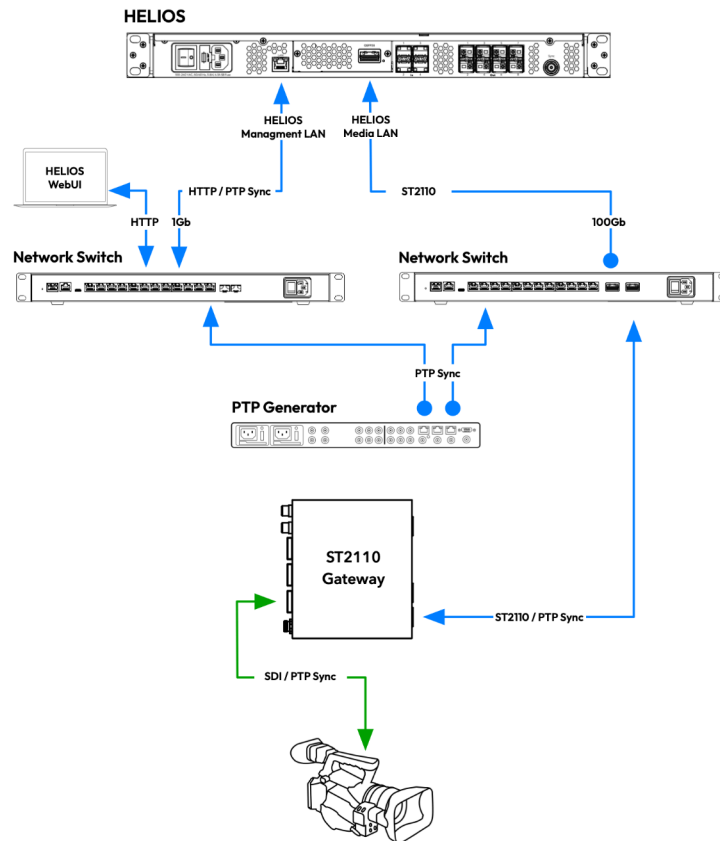

Figure 228: A basic ST 2110 system

The example below illustrates an ST 2110 system with a ‘device native’ ST 2110 signal being sent from a PC equipped with a Rivermax capable GPU. The Rivermax SDK glues together the NIC and GPU to enable interconnect, orchestration, and SMPTE ST 2110 specification compliance. Separately, a PTP (Precision Time Protocol) Generator device provides sync through the switch to HELIOS® and the Rivermax card.

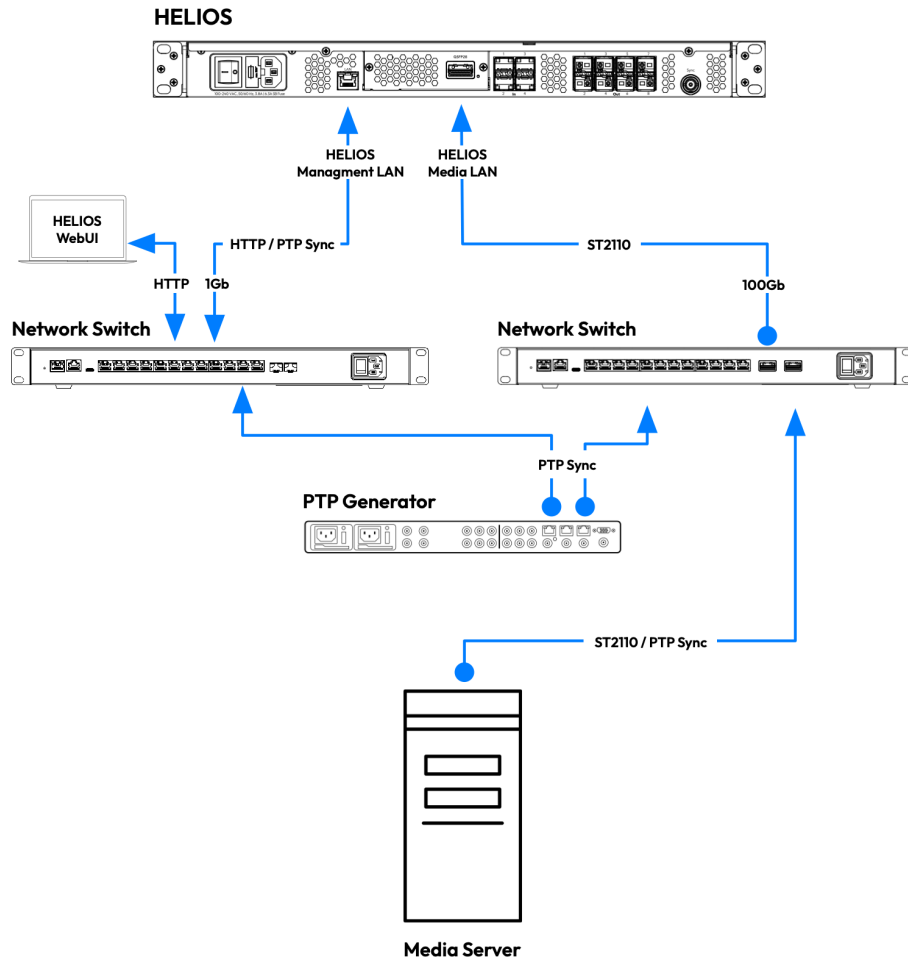

Figure 229: A native ST 2110 system

ST 2110 separates the audio, video, and metadata into separate synchronized streams. Streams can be transported independently over an IP link. This separation also allows for more flexibility but it also means that ST 2110 systems need to be configured to locate the streams. SDP (Session Description Protocol) records are small text files that describe the streaming media’s parameters to HELIOS®. SDP records are essential for locating and configuring an ST 2110 video signal. The SDP record tells HELIOS® which stream to use and what it is. On the following page is an example SDP record. The example can be used as a template for constructing an SDP record. Below the example are tables to help clarify the syntax and purpose of the file sections.

NOTE: HELIOS® can make use of manually added SDP records to manage ST 2110 streams. HELIOS® also supports the NMOS (Networked Media Open Specifications) protocol. NMOS allows for automatic discovery of devices and streams.

G.2 Example SDP Record

The structure of the file is fairly simple*. To the left of the equals sign are the parameter types, on the right of the equals sign are the parameter values <type>=<value>. The following text is an example of an SDP record file with the required lines for HELIOS®. The file is comprised of several sections. The first section is the Session Level and begins with **v=0**.

```
v=0
o=- 0 0 IN IP4 169.254.165.93
s=rivermax_player
t=0 0
m=video 50000 RTP/AVP 112
c=IN IP4 239.100.9.10/32
a=rtpmap:112 raw/90000
a=mediaclk:direct=0 rate=48000
a=source-filter:incl IN IP4 239.100.9.10 169.254.165.93
a=fmtp:112 sampling=YCbCr-4:2:2; width=1920; height=1080; exactframerate=24000/1001;
depth=12; TCS=SDR; colorimetry=BT2020; PM=2110GPM; TP=2110TPN; SSN=ST2110-20:2017;
```

* SDP records use the ISO 10646 character set in UTF-8 encoding. SDP field names and attribute names use only the US-ASCII subset of UTF-8, but textual fields and attribute values MAY use the full ISO 10646 character set.

G.2.1 Session Level

Type	Name	Components	Notes
v	Protocol version	v=0	The version of the Session Description Protocol
o	Originator and session identifier	O=<username> <sess-id> <sess-version> <nettype> <addrtype> <unicast-address>	"-" Is set for the user when the originating host does not support user IDs.
s	Session name	s=<session name>	Must not be empty and should contain ISO 10646 characters.
t	Time the session is active	t=<start-time> <stop-time>	0 0 = not time-limited

G.2.2 Media Level

Type	Name	Components	Notes
m	Media name and transport	m=<media> <port> <proto> <fmt>	Dynamic payload type 112 is used for uncompressed video. Payload type must also match attribute lines a=rtpmap and a=fmtp
c	Connection data	c=<nettype> <addrtype> <connection-address>	IN is defined as "Internet"

G.2.3 Media Level Attributes

Type	Name	Components	Notes
a=rtpmap	RTP payload format	a=<payload type> <encoding name>/<clock rate>	Dynamic payload type 112 must match the m=line
a=mediaclk	Clock mapping	direct=0	Always has a value of zero because no offset is needed between the media clock and the RTP clock.
a=source-filter	Source Filter	a=<nettype> <address-types> <dest-address> <src-list>	Helps protect receivers from traffic sent from illegitimate source addresses.
a=fmtp	Format specific parameters	a=<payload type> must match a=rtpmap (above) + other parameters separated by a ';' and a space	Dynamic payload type 112 must match the m=line. Parameters are passed unchanged to the media tool that is creating the stream.

G.3 NMOS Overview

The Networked Media Open Specifications (NMOS) provide control solutions for IP connected audio and video devices. Megapixel has built NMOS functionality into the HELIOS® processor to support SMPTE ST 2110. With the NMOS functionality, HELIOS® can connect and configure media devices to enable video on an ST 2110 network. The diagram below shows the network connections between the NMOS network devices.

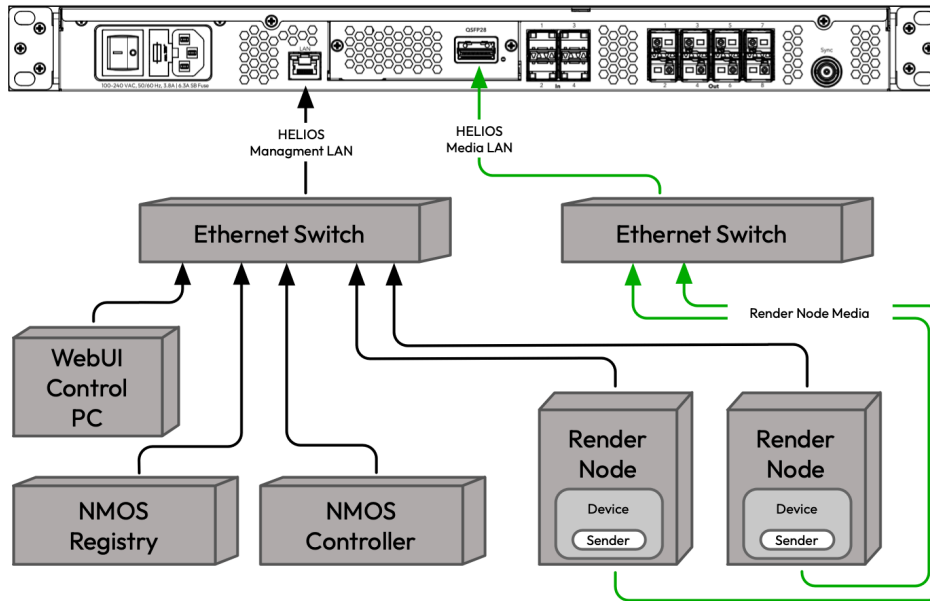

Figure 230: HELIOS® NMOS network connections

NOTE: As the above image shows, HELIOS® supports NMOS on the **Management LAN**. The inbound content from render nodes is supported on the Media LAN.

Listed below are the key NMOS components and their functions.

NMOS Registry:

- A software application that provides a centralized registration service. This is where NMOS nodes (devices, senders, receivers) can automatically register themselves and their capabilities using the registration API.
- Exposes a query API that allows nodes to discover other registered nodes, their resources (senders, receivers, flows), and capabilities.

NMOS Controller:

- A software application that discovers, connects, and manages resources like nodes, devices, senders, and receivers.
- Queries the registry to discover the network topology and available nodes/resources.
- Retrieves SDP records from senders and instructs receivers to connect to specific sender streams.
- Can create, modify, and delete media flows between senders and receivers on demand.
- Reserves and allocates network resources like bandwidth required for media flows.
- Monitors media flow status and performs network diagnostics using events from nodes.

G.3 NMOS Overview

NMOS Node:

- Represents a single hardware or software instance.
- NMOS nodes are the various sources, destinations, and logical groupings of media resources in an ST 2110 network.
- Nodes can contain multiple Devices.

NMOS Device:

- Is hosted within an NMOS Node.
- Can contain multiple Senders and Receivers. As an example, the HELIOS® device hosted by the HELIOS® node contains four (4) receivers.

NMOS Sender:

- A logical source of media (video, audio, or data) that can be connected to one or more Receivers.

NMOS Receiver:

- A logical destination for media that can be connected to one or more Senders.

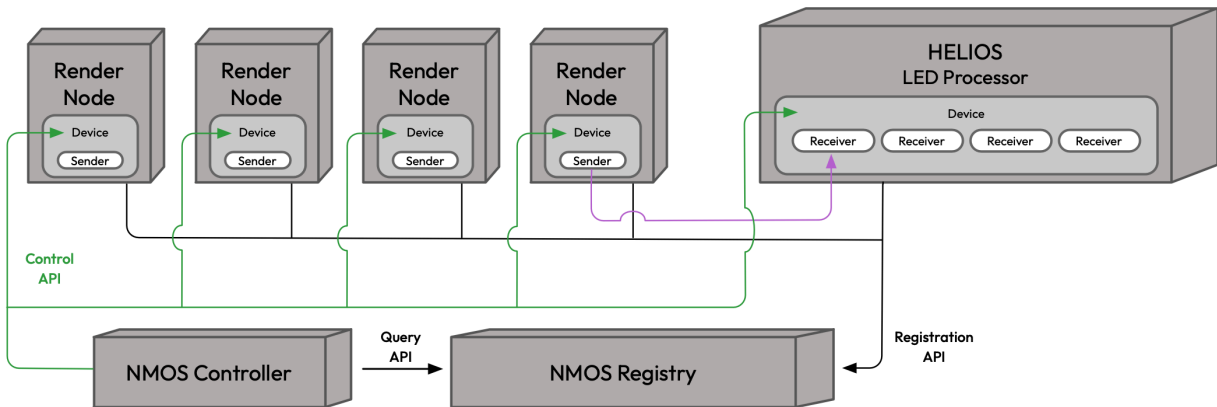

Figure 231: NMOS topology

TL;DR The NMOS Registry keeps track of the nodes on the network and what they can do. The NMOS Controller takes that information and uses it to connect the nodes and make things happen on the network.

The core NMOS specifications, IS-04 and IS-05 define how the system automatically connects:

1. Nodes automatically discover and register themselves with a Registry (IS-04) when connected to the network.
2. The Controller queries the registry (IS-04) to find available Senders and Receivers and their capabilities.
3. The Controller instructs a sender to send video on the network and instructs a receiver to accept video from a sender (IS-05). Depending on the equipment and software in use, the process of configuring senders and receivers can be a manual process where the user interacts with a web UI to manually patch senders to receivers.

G.3.1 NMOS Setup

With NMOS enabled (**Settings > Processor Settings > NMOS**) the HELIOS® will use mDNS to discover the NMOS Registry. These informational fields are read only.

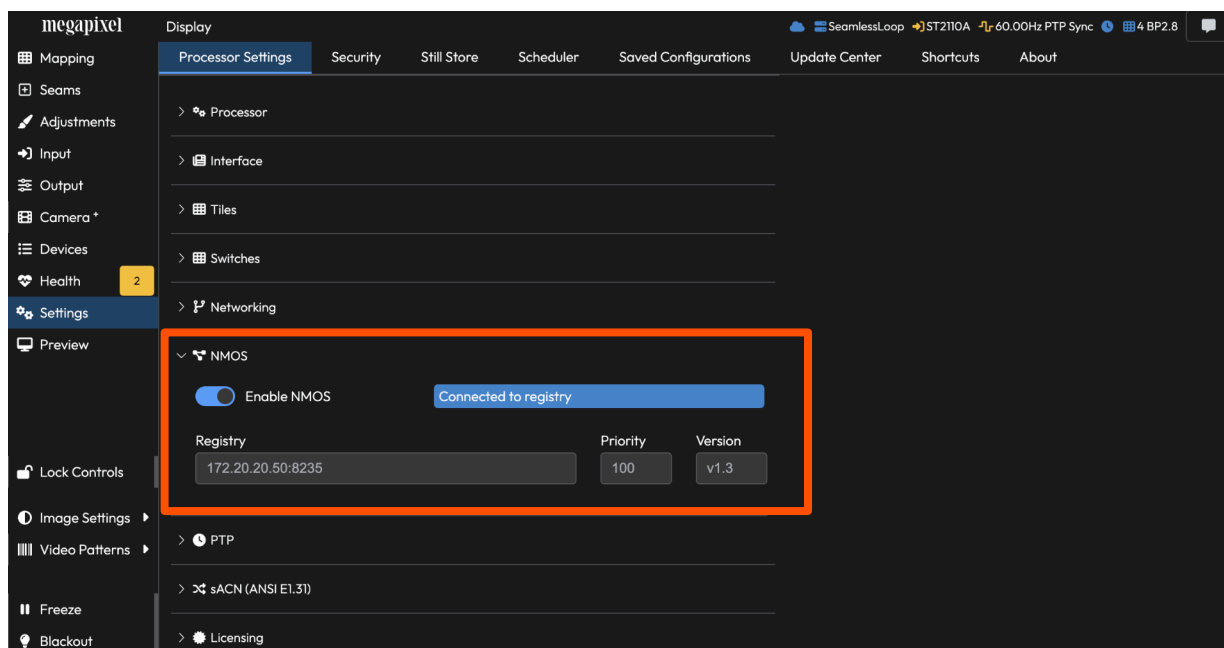

Figure 232: NMOS toggle

Select the desired ST 2110 source on the **Input** pane > **Input** accordion. Expand the disclosure triangle of an input to view details.

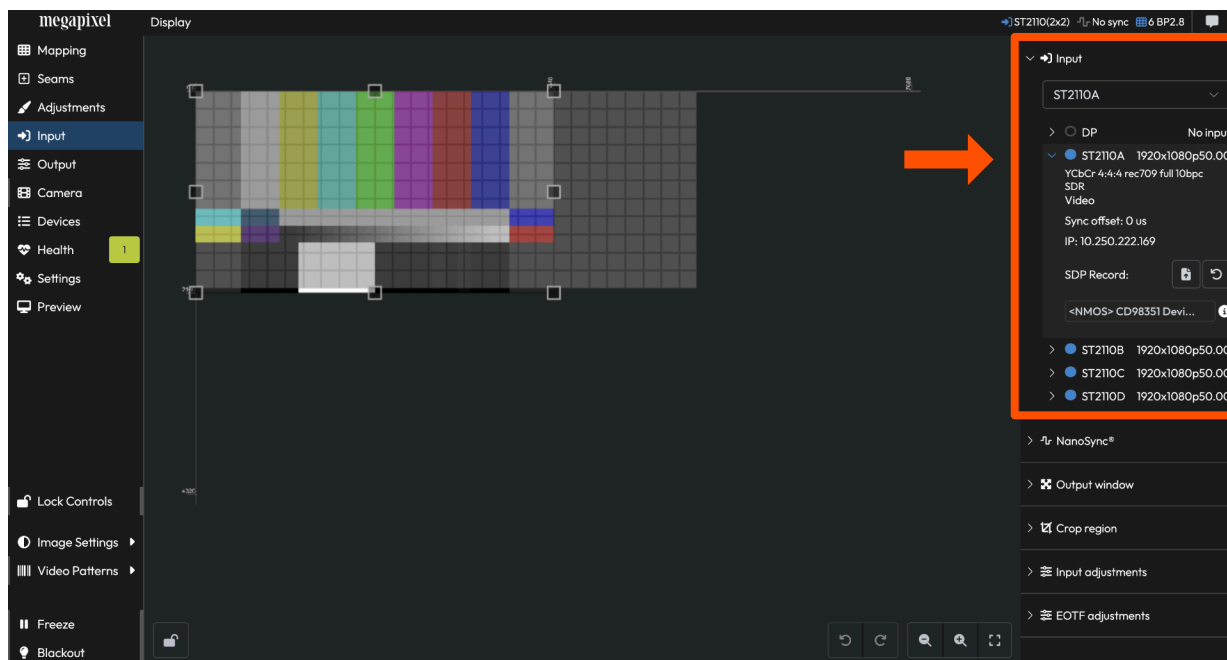



Figure 233: NMOS details

G.3.1 NMOS Setup

In the example below, HELIOS® displays the currently applied SDP record. This record was received from the NMOS system as is evident in the name of the SDP record being prefixed with **<NMOS>**. Click on the information icon (arrow below) to open the SDP record details window. Icon buttons at the top right of the window provide quick access to  **copy** the SDP record to the users clipboard and provide a  **download** of the SDP record.

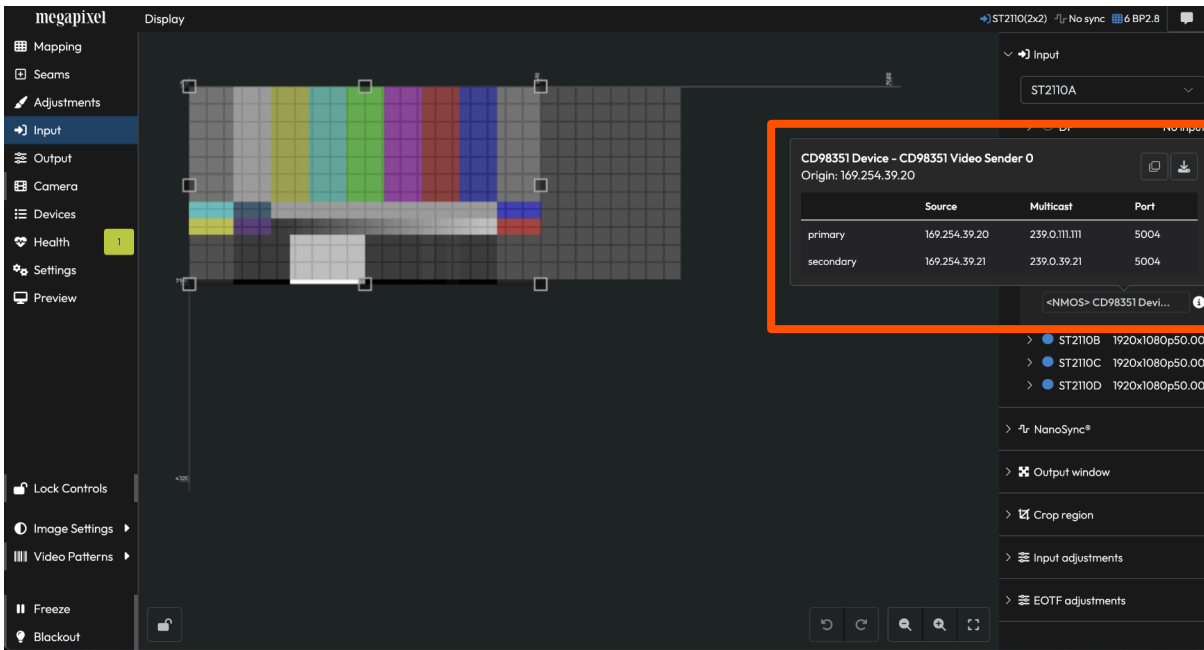

Figure 234: NMOS details window

HELIOS® supports redundant streams. Some vendors refer to the primary and secondary streams as ‘paths’ or ‘legs’. The HELIOS® 100G receivers have two (2) ‘legs’ or ‘paths’ for receiving a primary and secondary video source. The 10G inputs on HELIOS® advertise only one (1) leg per receiver and do not support redundant streams. If a secondary ST 2110 stream has been assigned to the HELIOS® 100G input, the connection information will be shown in the SDP record details window (image above).

G.4 PTP Settings

The HELIOS® **Processor > Settings** have an Enable / Disable PTP toggle. The domain value serves as an identifier for PTP messages and devices. Devices use the domain value to filter and process only the PTP messages relevant to their domain. Configure the domain to match the sending PTP device. PTP supports up to 256 domains (0-255). The default domain is 127. When PTP is set in the SDP record, it still needs to be globally enabled in the **Processor > Settings**. HELIOS® will then prefer to use PTP for that ST 2110 stream.

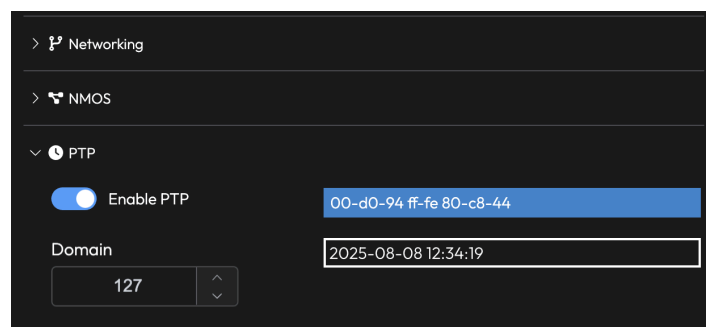

Figure 235: PTP Processor Settings

G.5 ST 2022-7 Redundant Streams

SMPTE ST 2022-7 is a standard for seamless reconstruction of RTP datagrams. RTP (Real-time Transport Protocol) is the underlying protocol used to carry ST 2110 video over an IP network. An ST 2110 video stream is broken into small, individually addressed RTP packets commonly referred to as datagrams, each carrying a portion of the video signal.

In a typical primary/secondary or red/blue network configuration, two identical streams are sent via separate network paths. HELIOS® reconstructs the transmitted stream by using whichever datagram arrives cleanly first, on a packet-by-packet basis. This is what the ST 2022-7 standard calls "seamless reconstruction". As a lost datagram, or complete loss of one of the transmitted streams, results in no perceived loss of video signal.

The HELIOS® 100G input implements ST 2022-7. When a secondary stream is present, HELIOS® monitors both paths and reconstructs automatically. No user action is required. Whether the transition between streams is seamless depends on the skew between the two paths:

- Low skew (local streams): When both streams arrive within a small time differential, HELIOS® can absorb the difference and switch without any visible disruption to the output.
- High skew: If the path differential exceeds the receiver buffer, HELIOS® will still switch to the backup stream when the primary fails, but the transition may produce a brief visible disruption.

NOTE: The 10G inputs on HELIOS® do not support redundant streams. ST 2022-7 redundancy is only available on the 100G input. See Section K.9 for ST 2110 input specifications.

Bandwidth and 8K Streams

A common question is whether an 8K stream leaves room for a redundant second stream on a 100G input. It does. An 8K signal does not consume the full bandwidth of a 100G link, so both the primary and secondary streams can be carried simultaneously without exceeding input capacity.

Dual-HELIOS® Configuration with ST 2022-7

Users operating two HELIOS® processors on separate Red and Blue networks can combine ST 2022-7 with HELIOS® native redundancy to achieve layered protection:

- ST 2022-7 provides redundancy at the input stream level, automatically recovering from packet loss or path failures on either network.
- HELIOS® Seamless mode ([Appendix F](#)) provides redundancy at the processor level, so a hardware failure on one unit does not interrupt the display.

In this configuration, each HELIOS® receives its respective stream path (one processor on Red, one on Blue). If the upstream sender or one network path fails, ST 2022-7 handles recovery at the input. If a processor itself fails, HELIOS® Seamless mode handles recovery at the output.

NOTE: In all ST 2022-7 configurations, HELIOS® identifies and correlates the primary and secondary streams using their SDP records. Ensure that both paths are described with accurate SDP records and that they match the expected stream parameters.

H - Masks

H.1 Overview

Group masks are primarily intended for blacking out edge pixels, adding rounded corners, and avoiding a physical mask from half covering pixels.

Masks are assigned to tile groups in the group settings. Create a tile group, then open the group settings window with the settings icon button  in the groups accordion or by right clicking the desired group and selecting **Group Settings...**

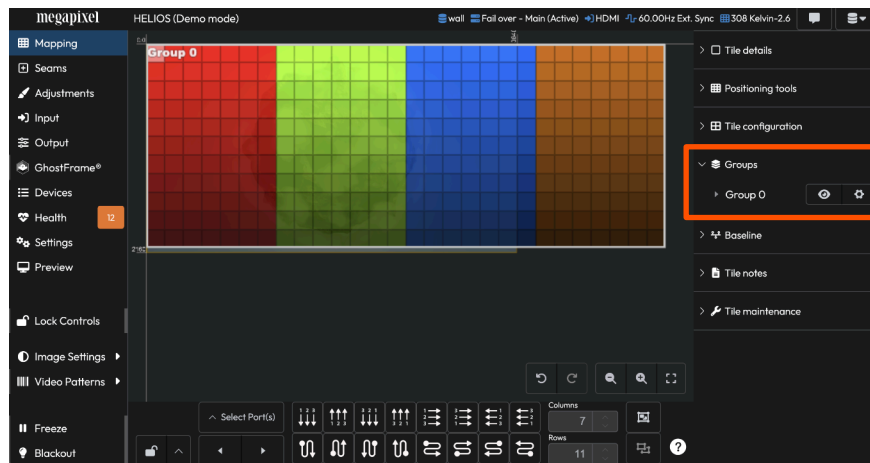

Figure 236: Tile group settings button

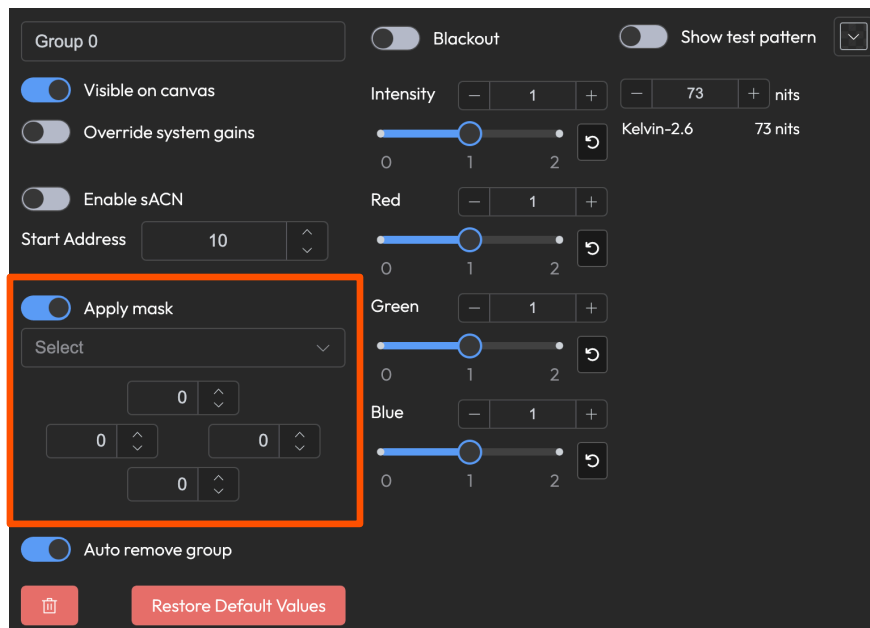

Figure 237: Tile group settings window

H.2 Mask Image Requirements

Masks are uploaded and stored in the HELIOS® still store and any JPEG or PNG image may be used as a mask. Only PNG files support alpha channels.

Alpha channel will be used when available (PNG) and when any pixel value is below 255. Otherwise, the green channel will be used (JPEG/PNG).

	Mask	Video
Alpha Channel	Opaque	Transparent
Green Channel	Black	Green/ White

H.3 Mask Behavior

- Masks are algorithmically extended to fit the group's boundaries. HELIOS® analyzes the image to determine how much of each edge is non-repeating, then repeats the middle section. See the [H.6 Mask Algorithm](#) for more details.
- If the mask should not be extended, upload a mask image which has the same dimensions as your display group.

H.4 Tile Group Behavior

When a mask is applied to a tile group, HELIOS® treats the entire group as a single masked canvas. The mask image is extended to the group's boundaries using the mask algorithm. Adding or removing tiles from the group changes how the mask spans the group. See the [Rounded Top](#) mask section for example images.

- When a mask is applied to a tile group that contains a single tile, the mask only affects that tile. As additional tiles are added to the same group, the mask automatically spans all tiles in that group.
- Different tile groups can use different masks. Each group's mask is extended independently to match that group's layout and dimensions.
- Because mask pixels are not scaled, repeating or patterned areas of the mask (such as “teeth” or borders) may repeat across multiple tiles as the group grows.

H.5 Mask Nudging

Mask edges may be nudged per side to fine-tune the visible result. See the [Diamond Border](#) mask section for an example image.

- Each edge (left, right, top, bottom) can be nudged by up to 1000 pixels. The smaller the source mask, the less room there is available to nudge.
- A positive nudge value increases that edge, enlarging the visible masked area. A negative nudge value shrinks the mask from that edge, adding a visible black border or shifting the position of repeating patterns.
- Nudging is especially useful for quickly adding black borders, aligning rounded corners, or lining up repeating features such as diamond “teeth” between tiles.

H.6 Mask Algorithm

Mask pixels are kept the same size. HELIOS® does not just stretch/scale to fit the group. Instead HELIOS® chops up the mask into sections and truncates or repeats the middle section to fit the group. This is what causes the teeth to repeat and extends the border between the curve regions.



Figure 238: Mask algorithm example

The above example is the ideal case, where the middle sections perfectly repeat. In other cases the last section will be truncated, which for flat middle masks is not visible, while teeth style masks do require nudging.

The advantage of this algorithmic masking approach is more general masks can be used. The example images on the previous page can all be applied to any display, regardless of size. This allows designers to focus on their preferred radius which can then be used with a variety of walls since the middle sections will be repeated.

In the case of more detailed masks, or if the user wants full control, ensure the uploaded mask dimensions match that of the display.

H.7 Mask Mayhem

Note that accidentally inverting the mask colors, or just using a random image, can result in some fun results:

The example below shows an incorrectly inverted 32x32 pixel mask on a 192 x 192 pixel tile, which the mask algorithm repeated as best it could.

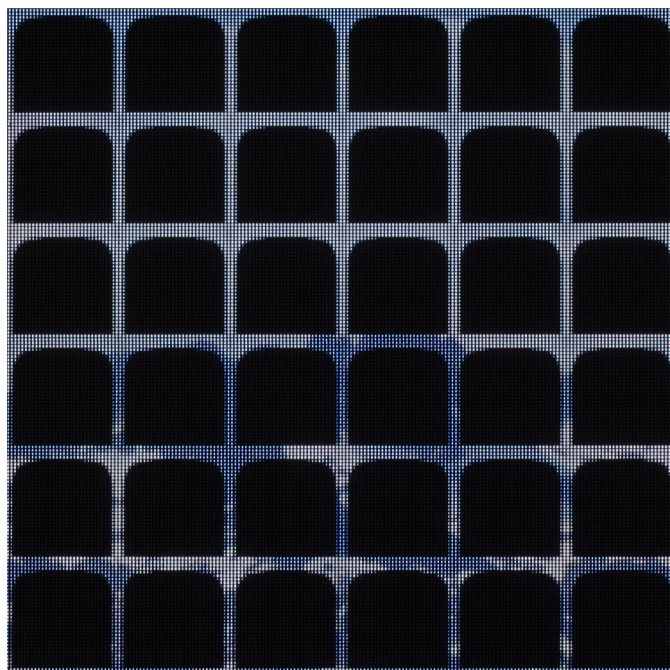

Figure 239: Inverted Mask Issue example

H.8 Example Masks

Two Pixel Border

The Two Pixel Border mask is a very small mask. It measures only 10 x 10 pixels square. This mask is a great example of how the HELIOS® enlarges a mask without stretching it. The example below has been scaled up for the purpose of this guide. Actual dimensions are 10 x 10px with a 2px black border.

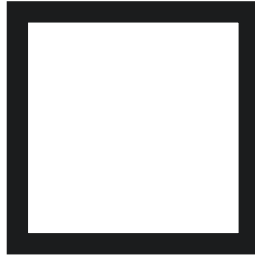

Figure 240: Two pixel border mask

Below is an example of the Two Pixel Border on a single tile. Note the thin black border the mask has created on the tile. As mentioned earlier in the [H.4 Tile Group Behavior](#) section, when the Two Pixel Border mask is applied to a tile group, it forms a two (2) pixel black boundary on the entire tile group.



Figure 241: Two pixel border mask applied

H.8 Example Masks

Rounded Top

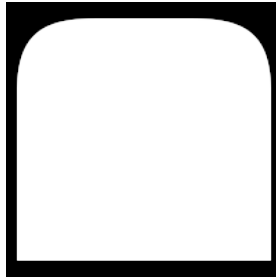

Figure 242: Rounded top mask

The rounded top mask in the example below as applied to a single tile.



Figure 243: Rounded top mask on a single tile

The rounded top mask in the example on the left has been applied to only one (1) tile (the tile group has only one tile). On the right, the lower tile has been added to the tile group so the mask spans both tiles.

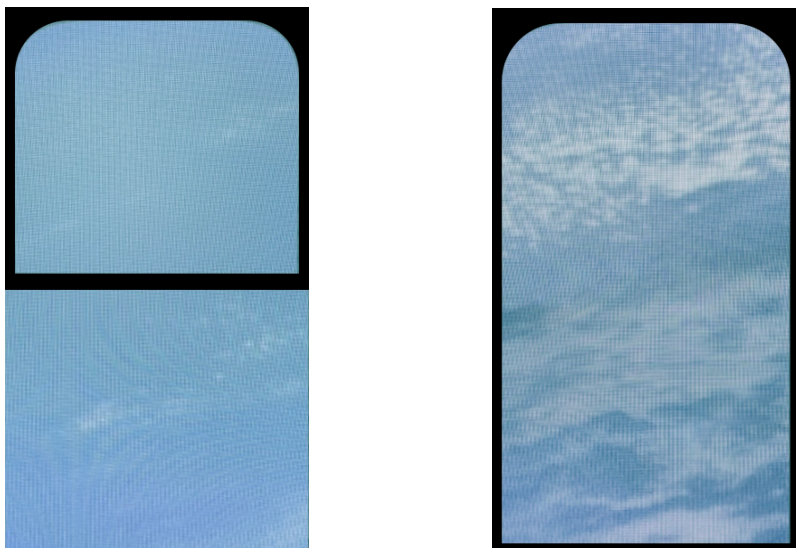

Figure 244: Tile group behavior

H.8 Example Masks

Diamond Border

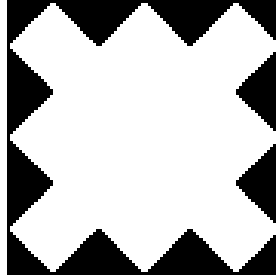

Figure 245: Diamond border mask

In the examples below the Diamond Border Mask has been applied to a two (2) tile group. The example on the left shows the mask without any nudging. On the right, the mask has been nudged with the values (-8, -4, -8, -4). Due to the negative nudge values being used, a slightly thicker black perimeter is visible on the right tile.



Figure 246: Nudge example

H.8 Example Masks

Asymmetric



Figure 247: Asymmetric mask

The mask algorithm is aware of asymmetric masks. The mask does not need to be the same size as the group, the mask algorithm is able to handle the size difference. In the example below, it trims the seats.

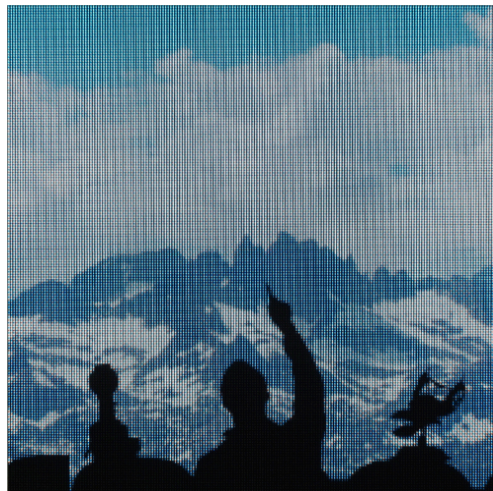

Figure 248: Asymmetric mask applied

I - HELIOS® HTTPS

I.1 Overview

HELIOS® supports both HTTP and HTTPS ('secure') connections. By default HELIOS® will generate a self-signed certificate, which is not inherently trustworthy, as anyone can generate a self-signed certificate with arbitrary contents. For an HTTPS connection to be secure, and not show a browser warning, it needs to be verifiable by a certificate authority (CA). Certificates can only refer to fully qualified domain names (FQDN).

Requirements:

- HELIOS® must be resolvable via DNS (e.g., <https://my-helios.com>)
- HELIOS® must have a certificate signed by a trusted CA

Most enterprises have their own internal trusted CA and internal DNS, which can fulfill these requirements. Others may end up placing HELIOS® on the internet (not recommended).

For testing, it is possible to generate and trust a self-signed certificate, and use the hosts file to provide DNS resolution.

I.2 Workflow

1. Determine the FQDN and ensure HELIOS® is reachable via that FQDN
2. Generate a private key pair that meets the CA's requirements (e.g., RSA 4096, ECC 256)
3. Generate a CSR (Certificate Signing Request) for that FQDN
4. CA takes the CSR and generates a signed certificate
5. Include required intermediary certificates with the signed certificate (chain of trust)
6. Upload bundled certificate + private key to HELIOS®

I.3 Certificate & Key PEM file format

Both the certificate and private key are expected to be in PEM format as defined by RFC7468.

A certificate PEM file should start with:

```
-----BEGIN CERTIFICATE-----
```

While a private key PEM file should start with one of these:

```
-----BEGIN PRIVATE KEY-----
```

```
-----BEGIN ENCRYPTED PRIVATE KEY-----
```

```
-----BEGIN EC PRIVATE KEY-----
```

I.4 Including intermediary certificates

Often the CA generating the certificate is using an intermediary certificate, which is trusted by one or more other intermediary certificates, before being ultimately trusted by a root certificate. As most devices only have knowledge/trust of the root certificates, often the intermediaries need to be included to complete the chain of trust.

To complicate matters, most modern browsers include many of these intermediary certificates or know how to retrieve them, which results in the site appearing secure from some systems but not others. A good example of this is where Chrome says the site is secure, while Megapixel's OMNIS® AV Monitoring Platform does not.

In the case of OMNIS®, it is only aware of the root certificates, so without knowledge of the intermediaries, the HELIOS® certificate cannot be verified.

To resolve this, we can include the intermediaries in the certificate file that we upload to HELIOS®. A PEM file is a plain text file, which contains a base64-encoded X.509 certificate between two tags. We can just concatenate additional certificate entries to this file. Convention is to have the least authoritative certificate first.

```
-----BEGIN CERTIFICATE-----  
... Device cert ...  
-----END CERTIFICATE-----  
-----BEGIN CERTIFICATE-----  
... Intermediary CA ...  
-----END CERTIFICATE-----  
-----BEGIN CERTIFICATE-----  
... Intermediary CA 2 ...  
-----END CERTIFICATE-----
```

I.5 Verifying uploaded certificate

Here, we have not included the intermediaries, so it is failing:

```
% openssl s_client -showcerts -connect my-helios.com:443
CONNECTED(00000003)
depth=0 CN = my-helios.com
verify error:num=20:unable to get local issuer
certificate
verify return:1
depth=0 CN = my-helios.com
verify error:num=21:unable to verify the first
certificate
verify return:1
write W BLOCK
---
```

While in this case we have included the intermediaries, so it can resolve that it was issued by Let's Encrypt:
(**my-helios.com** has been substituted in the example below)

```
% openssl s_client -showcerts -connect my-helios.com:443
CONNECTED(00000003)
depth=2 C = US, O = Internet Security Research Group, CN = ISRG
Root X1
verify return:1
depth=1 C = US, O = Let's Encrypt, CN = R3
verify return:1
depth=0 CN = my-helios.com
verify return:1
write W BLOCK
---
```

I.6 HSTS

HTTP Strict Transport Security is a way for a site to advertise that all connections must be via https, which prevents downgrade attacks, as browsers default to trying http:// first, before https://.

- HSTS is a flag set in the response by the web server when a user visits the site. After which the browser will remember this flag, so future connections will always be via https. Browsers will also then straight out refuse to connect via plain http unless this behavior is overridden.
- HSTS only applies to FQDN connections. So connections by IP will ignore this flag.
- HELIOS® will only set the HSTS flag if **Redirect to HTTPS** is enabled.
- HELIOS® must be resolvable via FQDN.
- HELIOS® must have **Redirect to HTTPS** enabled.

To verify:

```
% curl -i https://my-helios.com
HTTP/1.1 200 OK
Strict-Transport-Security: max-age=31536000; includeSubDomains
...
```

I.7 Generating a self-signed certificate

The command below will provide a private key (key.pem) and certificate (cert.pem), which can then be uploaded to HELIOS® via network settings.

Mac:

```
openssl req -x509 -newkey rsa:4096 -nodes -keyout key.pem -out cert.pem -sha256 -days 365 -
extensions ext -config <(cat /System/Library/OpenSSL/openssl.cnf \
<(printf '[ext]\nextendedKeyUsage=serverAuth\n'))
```

NOTE: The **serverauth** extension is required to prevent browsers complaints about an invalid key.

I.8 Supported ciphers

Supported SSL ciphers can be checked by using nmap with the following script (stackoverflow).

With HELIOS® 23.12:

```
% nmap -p 443 --script './ssl-enum-ciphers.nse.txt'
192.168.10.99
Starting Nmap 7.94 ( https://nmap.org ) at 2023-11-11 11:51 NZDT
Host is up (0.00012s latency).

PORT STATE SERVICE
1338/tcp open  wmc-log-svc
| ssl-enum-ciphers.nse:
|   TLSv1.2:
|     ciphers:
|       TLS_ECDHE_RSA_WITH_AES_128_GCM_SHA256 (ecdh_x25519) - A
|       TLS_ECDHE_RSA_WITH_AES_256_GCM_SHA384 (ecdh_x25519) - A
|       TLS_ECDHE_RSA_WITH_AES_128_CBC_SHA256 (ecdh_x25519) - A
|       TLS_ECDHE_RSA_WITH_AES_256_CBC_SHA384 (ecdh_x25519) - A
|       TLS_ECDHE_RSA_WITH_CHACHA20_POLY1305_SHA256 (ecdh_
x25519) - A
|       TLS_ECDHE_RSA_WITH_AES_256_CBC_SHA (ecdh_x25519) - A
|       TLS_ECDHE_RSA_WITH_AES_128_CBC_SHA (ecdh_x25519) - A
|     compressors:
|       NULL
|     cipher preference: server
|   TLSv1.3:
|     ciphers:
|       TLS_AKE_WITH_AES_256_GCM_SHA384 (ecdh_x25519) - A
|       TLS_AKE_WITH_CHACHA20_POLY1305_SHA256 (ecdh_x25519) - A
|       TLS_AKE_WITH_AES_128_GCM_SHA256 (ecdh_x25519) - A
|     cipher preference: server
|_  least strength: A

Nmap done: 1 IP address (1 host up) scanned in 0.74 seconds
```

I.9 Security settings for HTTPS

Security settings for a HELIOS® HTTPS deployment:

1. Create an Admin or more users
2. Enable user authentication

See the [Security](#) section for more details.

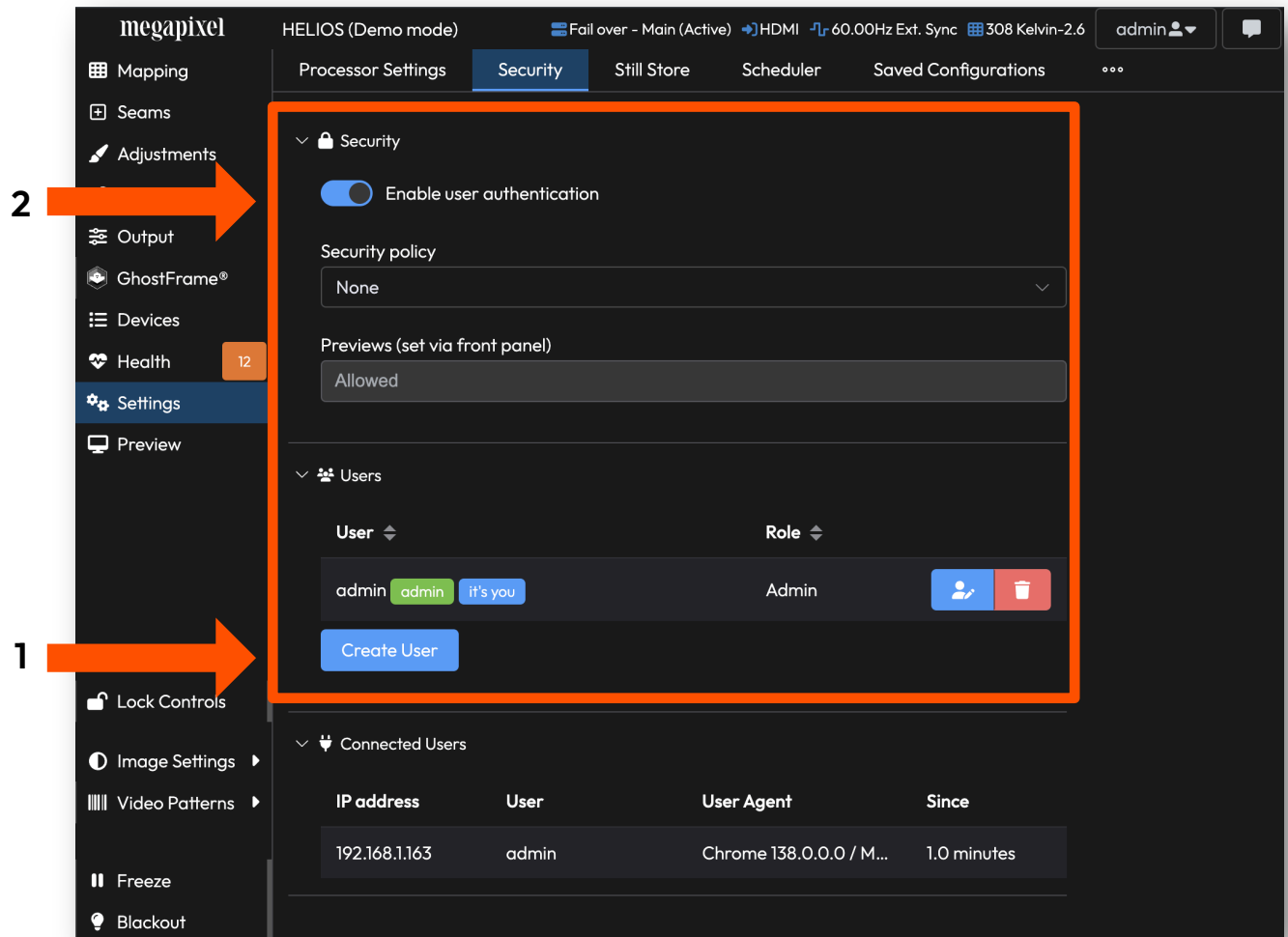

Figure 249: Networking Advanced

J - HDR Workflows

This appendix provides a pipeline-level framework for understanding and maintaining HDR image integrity across the full video signal chain. It covers the five stages of the HDR pipeline, the core parameters that must be consistent at each stage, the most common sources of HDR error, upstream configuration guidance, and a quick diagnostic checklist for troubleshooting.

The HELIOS® controls referenced throughout this appendix are documented in the main body of the guide: EOTF Adjustments (Section 5.5.10), High Dynamic Range (Section 5.5.12), Display Gamut (Section 5.6.1), and Calibration Report (Section 5.6.2).

J.1 HDR as a Pipeline, Not a Setting

HDR on HELIOS® is comprised of several features all working together: bit depth, gamut, and decoding with an HDR transfer function. Standard definition content uses the typical SDR gamma curve. HDR uses an entirely different function to map a higher range of brightness onto a display. HDR is more than just brightness; it also includes a wider range of colors. As such, the system must use, at minimum, 10-bit color. HELIOS® should ideally be set to 12-bit if possible. Check that the bandwidth is sufficient under the **Outputs** pane **Display bit depth** accordion.

A true HDR result requires that the entire pipeline — from content creation to the display wall — is aligned and capable of supporting HDR. HDR is a chain of dependencies, not a single deliverable. Misconfiguration at any stage will affect the final image, regardless of how HELIOS® is configured.

The five stages of the HDR pipeline are:

Stage	What Happens Here	Common HDR Risk
1. Content Creation	HDR grading, color space selection, mastering to nit target	Unintended tone mapping baked in; inconsistent color space
2. Packaging & Playback	Codec decode, media server color handling, metadata recognition	Bit depth truncation; unintended in-player transforms
3. Signal Transport	HDMI / DisplayPort / SMPTE ST 2110 transmission	Metadata stripped in transit; HDMI as conditional path*
4. Signal Transformation	LED processor (HELIOS®) color conversion, EOTF decode, tone mapping	Cascading transforms; EOTF mismatch; gamut misinterpretation
5. Display	LED tiles — final luminance, gamut, calibration	Display capability vs. mastering mismatch; calibration drift

* HDMI does not guarantee reliable HDR metadata passthrough — cables, intermediate devices, and source drivers can all silently strip or alter it. Validate HDMI HDR signal integrity per deployment. See [J.4.3 Signal Transport](#) for full guidance.

NOTE: HELIOS® operates at Stage 4 — Signal Transformation. Its behavior is directly shaped by the quality and consistency of every stage that precedes it. If HDR output is not as expected, the issue may originate upstream of HELIOS®.

J.2 Core HDR Parameters

For HDR to be maintained across the pipeline, the following parameters must be explicitly defined and consistently preserved at every stage. A mismatch in any one of these values between systems is a common source of HDR error.

Parameter	Value / Standard	Role in HDR Pipeline
Luminance Target	Peak nit value (e.g., 1000 nits)	Determines tone mapping and roll-off behavior
Color Space	Rec.2020 (signal); P3 (typical content)	Defines the range of reproducible color
Bit Depth	10-bit minimum; 12-bit preferred	Preserves gradations; prevents banding in HDR
Transfer Function (EOTF)	PQ (SMPTE ST 2084) or HLG	Maps encoded values to display luminance
Metadata	MaxCLL / MaxFALL (HDR10)	Informs processor of content light levels
Chroma Format	RGB or YCbCr; 4:4:4 / 4:2:2 / 4:2:0	Determines color fidelity; 4:2:0 not fully supported
Signal Range	Full range (0–255) vs. Legal/Limited (16–235)	Must match encoding to avoid clipping or crush

J.3 Common Points of Variation

The most frequently encountered sources of HDR inconsistency across real-world pipelines are:

- Gamut misinterpretation — content encoded in Rec.2020 displayed as Rec.709, causing desaturated output
- EOTF mismatch — PQ content treated as SDR, or SDR content processed with a PQ curve
- Metadata loss or override — MaxCLL/MaxFALL values stripped in transit or overridden by playback software
- Bit-depth truncation — a 10-bit signal downgraded to 8-bit at any point in the chain, introducing banding
- Cascading tone mapping — tone mapping applied at both the media server and HELIOS®, compounding errors
- Color drift (Delta E) — accumulated color error across calibration, processing, and display stages

NOTE: These variation points correspond directly to controls in HELIOS®. See the EOTF Adjustments, Color Range Override, Display Gamut, and Display Bit Depth sections for the relevant settings.

J.4 Upstream Pipeline Considerations

HELIOS® cannot correct for problems introduced earlier in the pipeline. The sections below describe the key considerations at each upstream stage and their impact on HELIOS® configuration.

J.4.1 Content Creation

Content should be mastered in a consistent color space (Rec.2020, or a controlled P3-to-Rec.2020 pipeline) and targeted to a defined peak luminance — typically 1,000 nits as a baseline. Tone mapping should not be baked into the export unless it is intentional and documented, as HELIOS® will apply its own handling based on the EOTF and luminance values it receives.

- Use Rec.2020 or a defined P3-within-Rec.2020 working space throughout the grade.
- Master to a defined nit target. HELIOS® reads the content max luminance value from the signal — an undefined or incorrect value will produce unexpected tone mapping.
- Export as ProRes 422 HQ or equivalent with HDR10 / PQ / Rec.2020 metadata intact.
- Avoid baking tone mapping into the export unless the downstream display and processor configuration is fixed and known.

J.4.2 Content Packaging and Playback

The media server or playback system is responsible for decoding the HDR file and transmitting a correct HDR signal to HELIOS®. Unintended transforms inside playback software — LUTs, color management profiles, or automatic HDR-to-SDR conversion — are a frequent source of signal inconsistency.

- Validate end-to-end 10-bit signal integrity from the decode stage through the output.
- Disable any unintended color transforms inside the playback system that are not part of the defined pipeline.
- Confirm that HDR metadata (MaxCLL, MaxFALL, EOTF type) is preserved by the playback system and transmitted correctly. Check the HELIOS® Input pane to verify what HELIOS® is receiving.

NOTE: Some playback systems default to applying their own color management or LUT processing. If HELIOS® reports unexpected EOTF values, investigate the playback system's color pipeline before adjusting HELIOS® settings.

J.4.3 Signal Transport

The transport path between the playback system and HELIOS® determines whether the HDR signal — including its metadata — arrives intact.

- SMPTE ST 2110 is the preferred transport path for HDR workflows. It provides predictable, metadata-reliable transmission.
- HDMI should be treated as a conditional path and validated per deployment. HDMI connections can strip or alter HDR metadata depending on the devices and cable quality involved.
- Avoid mixing transport formats (e.g., SDI and HDMI in the same signal path) without testing, as metadata handling is inconsistent across conversion devices.

NOTE: If HELIOS® reports that a PQ signal is SDR, it is likely that upstream equipment has stripped the PQ metadata in transit. Use the EOTF override in the Input pane to manually correct this. See Section 5.5.10 EOTF Adjustments.

J.5 HDR Quick Diagnostic Checklist

If HDR output appears incorrect — color appears desaturated, highlights are clipped, tone mapping is unexpected, or the image appears SDR — work through the following checks before making adjustments to HELIOS®.

Check	What to Verify in HELIOS®
Metadata present and interpreted correctly	Input pane > EOTF Adjustments: confirm EOTF is detected as PQ. Use EOTF override if metadata has been stripped upstream.
Bit depth maintained (10-bit minimum)	Output pane > Display bit depth: set to 12-bit where bandwidth allows; confirm no downgrade in the signal chain.
EOTF aligned across all systems	EOTF Adjustments: match EOTF to the mastering transfer function. Confirm playback device and HELIOS® are in agreement.
No unintended transforms in playback or processing	Disable any LUTs or color adjustments in the media server that are not part of the intended pipeline. Confirm Color range override matches encoding.
Display calibration and capability match content	Output pane > Display Gamut: confirm Target vs. Actual gamut alignment. Review Tile Calibration Report for Delta E and capability.

If the Issue Persists

If the checklist above does not resolve the issue, isolate the fault by testing with a known-good HDR source connected directly to HELIOS®, bypassing playback and transport systems. If HELIOS® correctly handles the reference source but not the production source, the problem is upstream.

- Check playback system output settings and confirm HDR metadata is being transmitted.
- Validate signal integrity at the transport layer — check for HDMI metadata stripping or format conversion issues.
- Review content export settings and confirm the correct EOTF, color space, and bit depth in the source file.

TIP: A useful reference workflow for HDR validation is ProRes 422 HQ / HDR10 / PQ / Rec.2020. This combination provides a known baseline at each stage of the pipeline and simplifies fault isolation.

J.6 Validation and Measurement

Delta E (ΔE) is the standard measure of perceptual color difference. A Delta E below 1.0 is imperceptible. Values above 3.0 are visible to the eye.

The [Tile Calibration Report](#) (**Output** pane > **Report**) shows gamut coverage percentages for each tile against Rec.2020, DCI P3, and Rec.709, giving a clear picture of whether tiles are hitting their color targets.

For Delta E measurement — a more precise assessment of color accuracy — external instrumentation such as a colorimeter is required. Combine report-based gamut coverage checks with visual inspection of highlight roll-off and shadow detail as part of a thorough commissioning workflow.

- Use Delta E measurement to assess calibration accuracy and consistency across panels.
- Validate visually as well as by measurement — pay particular attention to highlight roll-off and shadow detail. Measurement and perception can diverge; both should be checked.
- Perform regular recalibration to control Delta E variation as display performance changes over time.

K - Technical Specifications

K.1 RS12 Network Switch - Specifications Table

	RS12 Switch (MVR-0050)	Weather Resistant Enclosure (MVR-0051)
Dimensions	1.5 RU 482.5 x 65.6 x 255.1 mm 18.9 x 2.5 x 10.0 in	1.5 RU 490 x 87.5 x 304.8 mm 19.2 x 3.4 x 12.0 in
Weight	5.9 kg 13 lbs	2.27 kg 5 lbs
Power	Neutrik™ powerCON TRUE1 Input 100V-240V, 50/60Hz, 16A	N/A
Input	2 x Neutrik™ opticalCON DUO Single Mode Fiber (ports 13 and 14)	N/A
Output	12 x 1GbE/2.5GbE CAT6A IP65-rated Weatherproof Neutrik™ etherCONs	N/A
Operating Conditions	Indoor 0°C ~45°C	Outdoor Indirect Sunlight Only*
Processing	Megapixel, HELIOS® LED Processing Platform	N/A

K.2 M4250-12M2XF (MSM4214X) Network Switch - Specifications Table

	MSM4214X Switch (MVR-0041)
Dimensions (W x H x D)	440mm (17.32") x 43.21mm (1.70") x 100mm (3.93")
Power Requirements	100 - 240V AC, 50Hz/60Hz, 1A (IEC C14 Connector)
Weight	1.8 kg 4 lbs
IP Rating	Indoor only
Ambient Operating Temperature	10° to 40°C (50° to 104°F)
Certifications	UL, FCC (Class A), CE, WEEE, C-TPAT
Fiber Optic Input from HELIOS®	2 x 10Gb SFP+ Single Mode Fiber Input (LC)
Copper Output Ports	12 x 1Gb / 2.5Gb Ethernet (Video Output ports)
Maximum pixels per port	425,000 pixels (12-bit, 60Hz) = 918Mb/s per port
Maximum pixels per network switch	4,250,000 pixels (12-bit) = 9.18Gb/s per network switch

K.3 M4200-10MG-PoE+ (GSM4210P) Network Switch - Specifications Table

GSM4210P Switch (MVR-0003)	
Dimensions (W x H x D)	440mm (17.32") x 43.21mm (1.70") x 100mm (3.93")
Power Requirements	100 - 240V AC, 50Hz/60Hz, 1A (IEC C14 Connector)
Weight	2.1 kg (4.62 lb)
IP Rating	Indoor only
Ambient Operating Temperature	10° to 40°C (50° to 104°F)
Certifications	UL, FCC (Class A), CE, WEEE, C-TPAT
Fiber Optic Input from HELIOS®	1 x 10Gb SFP+ Single Mode Fiber Input (LC)
Copper Output Ports	8 x 1Gb / 2.5Gb Ethernet (Video Output ports) 1 x 1Gb Ethernet*
Maximum pixels per port	425,000 pixels (12-bit, 60Hz) = 918Mb/s per port
Maximum pixels per network switch	4,250,000 pixels (12-bit) = 9.18Gb/s per network switch

* 1Gb Ethernet uses the second SFP slot fitted with an MVR copper SFP for 1Gb video output.

K.4 I/O Module shipping weights

	Weight
100G SMPTE ST 2110 Upgrade Kit w/ Factory Installation KIT-0047	0.34 kg 0.75 lbs
12G SDI SFP+ Input (BNC) PCB-0006	0.23 kg 0.05 lbs
10G Fiber SFP+ 1270nm TX 1330nm RX 10km (HELIOS® Output) PCB-0008	0.23 kg 0.05 lbs
10G Fiber SFP+ 1330nm TX 1270nm RX 10km (Switch Input) PCB-0028	0.23 kg 0.05 lbs
1000Base-T Copper RJ45 1G SFP 100m (Switch Input) PCB-0029	0.23 kg 0.05 lbs
DisplayPort Input Module w/ Dual DP backplate KIT-0012	0.23 kg 0.05 lbs
HDMI Input Module w/ Dual HDMI backplate KIT-0013	0.23 kg 0.05 lbs

K.5 HELIOS® - Specifications Table

The following sections describe HELIOS® processor specifications; see K.1–K.4 for compatible network switches.

Dimensions (W x H x D)	481.5mm (19.0") x 44.2mm (1.7") x 414.5mm (16.3")	
Power Requirements	100 - 240V AC, 50Hz/60Hz, 3A (IEC C14 Connector) Typical power usage 65W max.	
Fuses	2 x 6.3A 250V Glass Tube Slow Blow, Ø 5 x 20mm	
Weight	5.7kg 12.6lb	
IP Rating	Indoor	
Ambient Operating Temperature	10° to 35°C	
Certifications	UL, FCC (Class A), CE, RoHS, CQC, UKCA, EAC, NOM, BIS, KCC, RCM	
Maximum pixels per Processor	35M pixels	
Heat Load	256 BTU/hr thermal dissipation	
HELIOS® web UI	1 x Gb Ethernet	
System Latency *	3 frames (@ 60Hz = 50ms @ 120Hz = 25 ms)	
Inputs		
HDMI 2.0b	1 x Input - HDMI 2.0b	
HDMI 2.1 (with optional card)	1 x Input - HDMI 2.1	
DisplayPort	1 x Input - DP 1.4 HBR3	
SDI	4 x Inputs:	SD and HD-SDI (Progressive only)
		3G and 6G SDI (level A and B)
		2SI on 12G-SDI **
10G ST 2110	4 x Inputs, 4 x Streams up to 4K @50Hz ea. (See detailed ST2110 specifications in Section K.9)	
100G ST 2110	1 x Input, 4 x Streams Input 'A' - up to 8K@60Hz Inputs 'B/C/D' - up to 4800 x 2700@60Hz ea. for a total of 8K@60Hz [†] (See detailed ST2110 specifications in Section K.9)	
PTP Sync	SMPTE ST 2059 2021	
Analog Sync	1 x - Black burst and Tri-level [‡]	

* Input to eyeball including network switches.

** Square Division is supported, but it cannot be scaled. Stitched inputs also cannot be scaled.

[†] A lower bit depth and/or frame rate allow for more pixels. Regardless of frame rate or bit depth, the maximum pixels per HELIOS® output port is 8.5 million.

[‡] Tested to work with: Evertz MSC5601, AJA GEN-10, BlackMagic Design CONVMSYNC

K.6 HELIOS® - I/O Configurations

K.6.1 - 8K Extreme IP Broadcast

Inputs	1 x 100Gb QSFP SMPTE ST 2110 supports 4 x 4K 60p streams or single 8K 60p 4 x 12G-SDI as independent 4K 60p inputs or stitched for 8K 60p
Resolution	Up to 8K (7680 x 4320 or 8192 x 4320)*
Outputs	8 x 10Gb Fiber SFP+ ** 9/125 Single mode (SMF) OS1 (<=1000m) or OS2 LC-LC terminated UPC Polish Riser / plenum rated
Genlock	Analog Tri-level Sync

K.6.2 - Standard 8K

Inputs	1 x DisplayPort 1.4 1 x HDMI 2.0 4 x 12G SDI
Resolution	Up to 8K (7680 x 4320 or 8192 x 4320)*
Outputs	8 x 10Gb Fiber SFP+ ** 9/125 Single mode (SMF) OS1 (<=1000m) or OS2 LC-LC terminated UPC Polish Riser / plenum rated
Genlock	Analog Tri-level Sync

K.6.3 - Standard 4K

Inputs	1 x DisplayPort 1.4 1 x HDMI 2.0 1 x 12G SDI (up to 4096 x 2160)
Resolution	Up to 4K (4096x2160)*
Outputs	2 x 10Gb Fiber SFP+ ** 9/125 Single mode (SMF) OS1 (<=1000m) or OS2 LC-LC terminated UPC Polish Riser / plenum rated
Genlock	Analog Tri-level Sync

K.6.4 - HELIOS® Jr.

Inputs	1 x DisplayPort 1.4 1 x HDMI 2.0 Optional Input SFP+, not included
Resolution	Up to 2K (2048 x 1080)*
Outputs	8 x 1G Copper SFP † RJ-45 Cat 6/Cat 6a
Genlock	Analog Tri-level Sync

*Higher frame rates at reduced resolution. Resolution and frame rates dependent on video standard.

** Maximum / port @12-bit, 60Hz: 4,250,000 pixels = 9.18Gb per output

† Maximum / port @12-bit, 60Hz: 425,000 pixels = 918Mb per output SFP

K.7 HELIOS® - Input Capability Matrices

The matrices below (and following page) show three (3) common refresh rates (30Hz, 60Hz, and 120Hz). HELIOS® supports any frequency between 15Hz and 120Hz. When capacity planning, use the rate in the table that is closest to the frequency that will be used. See [Chapter 2](#) System Planning for the bandwidth calculation formula that can be used for HDMI, DisplayPort, and ST 2110.

- **HDMI 2.0** indicates formats that operate on both HDMI 2.0 and HDMI 2.1 inputs. Any signal over HDMI 2.0 also operates over HDMI 2.1.
- **HDMI 2.1** indicates formats that require HDMI 2.1 and will not operate over HDMI 2.0.
- **DP** indicates formats supported over the DisplayPort input (DP 1.4).
- **SDI** indicates formats that can be carried over a single SDI input.
- **4× SDI** indicates formats that require four (4) synchronized SDI inputs (quad-link SDI).
- **10G** and **100G** refer to SMPTE ST 2110 over 10 GbE and 100 GbE inputs respectively. Any signal over 10G also operates over 100G.

30Hz								
	720p (1280 x 720)	1080p (1920 x 1080)	UHD (3840 x 2160)	DCI 4K (4096 x 2160)	5K (5120 x 2880)	6K (6016 x 3384)	8K (7680 x 4320)	DCI 8K (8192 x 4320)
RGB/YCC 4:4:4 12-bit	DP HDMI 2.0 10G	DP HDMI 2.0 10G	DP HDMI 2.0 10G	DP HDMI 2.0 10G	DP HDMI 2.1 100G	DP HDMI 2.1 100G	HDMI 2.1 100G	HDMI 2.1 100G
RGB/YCC 4:4:4 10-bit	DP HDMI 2.0 10G	DP HDMI 2.0 10G	DP HDMI 2.0 10G	DP HDMI 2.0 10G	DP HDMI 2.1 100G	DP HDMI 2.1 100G	HDMI 2.1 100G	HDMI 2.1 100G
RGB 8-bit	DP HDMI 2.0 10G	DP HDMI 2.0 10G	DP HDMI 2.0 10G	DP HDMI 2.0 10G	DP HDMI 2.1 100G	DP HDMI 2.1 100G	DP HDMI 2.1 100G	HDMI 2.1 100G
YCbCr 12-bit 4:2:2	DP HDMI 2.0 10G	DP HDMI 2.0 10G	DP HDMI 2.0 10G	DP HDMI 2.0 10G	DP HDMI 2.1 100G	DP HDMI 2.1 100G	DP HDMI 2.1 100G	HDMI 2.1 100G
YCbCr 10-bit 4:2:2	DP HDMI 2.0 10G SDI 10G	DP HDMI 2.0 10G SDI 10G	DP HDMI 2.0 10G SDI 10G	DP HDMI 2.0 10G SDI 10G	DP HDMI 2.1 10G	DP HDMI 2.1 100G	DP HDMI 2.1 4 x SDI 100G	DP HDMI 2.1 4 x SDI 100G

60Hz								
	720p (1280 x 720)	1080p (1920 x 1080)	UHD (3840 x 2160)	DCI 4K (4096 x 2160)	5K (5120 x 2880)	6K (6016 x 3384)	8K (7680 x 4320)	DCI 8K (8192 x 4320)
RGB/YCC 4:4:4 12-bit	DP HDMI 2.0 10G	DP HDMI 2.0 10G	DP HDMI 2.1 100G	DP HDMI 2.1 100G	HDMI 2.1 100G	100G	100G	100G
RGB/YCC 4:4:4 10-bit	DP HDMI 2.0 10G	DP HDMI 2.0 10G	DP HDMI 2.1 100G	DP HDMI 2.1 100G	HDMI 2.1 100G	HDMI 2.1 100G	100G	100G
RGB 8-bit	DP HDMI 2.0 10G	DP HDMI 2.0 10G	DP HDMI 2.0 100G	DP HDMI 2.0 100G	DP HDMI 2.1 100G	HDMI 2.1 100G	100G	100G
YCbCr 12-bit 4:2:2	DP HDMI 2.0 10G	DP HDMI 2.0 10G	DP HDMI 2.0 100G	DP HDMI 2.0 100G	DP HDMI 2.1 100G	HDMI 2.1 100G	100G	100G
YCbCr 10-bit 4:2:2	DP HDMI 2.0 10G SDI 10G	DP HDMI 2.0 10G SDI 10G	DP HDMI 2.0 100G SDI 100G	DP HDMI 2.0 100G SDI 100G	DP HDMI 2.1 100G	DP HDMI 2.1 100G	4 x SDI 100G	4 x SDI 100G

K.7 HELIOS® - Input Capability Matrices

	120Hz							
	720p (1280 x 720)	1080p (1920 x 1080)	UHD (3840 x 2160)	DCI 4K (4096 x 2160)	5K (5120 x 2880)	6K (6016 x 3384)	8K (7680 x 4320)	DCI 8K (8192 x 4320)
RGB/YCC 4:4:4 12-bit	DP HDMI 2.0 10G	DP HDMI 2.0 10G	HDMI 2.1 100G	HDMI 2.1 100G	100G	No	No	No
RGB/YCC 4:4:4 10-bit	DP HDMI 2.0 10G	DP HDMI 2.0 10G	HDMI 2.1 100G	HDMI 2.1 100G	100G	No	No	No
RGB 8-bit	DP HDMI 2.0 10G	DP HDMI 2.0 10G	DP HDMI 2.1 100G	HDMI 2.1 100G	100G	No	No	No
YCbCr 12-bit 4:2:2	DP HDMI 2.0 10G	DP HDMI 2.0 10G	DP HDMI 2.1 100G	HDMI 2.1 100G	100G	No	No	No
YCbCr 10-bit 4:2:2	DP HDMI 2.0 10G	DP HDMI 2.0 10G	DP HDMI 2.1 100G	DP HDMI 2.1 100G	100G	No	No	No

NOTES:

- HDMI signals cannot exceed 4K, regardless of bandwidth.
- HDR (High Dynamic Range) using both PQ and HLG is supported on all interfaces.
- The absolute maximum bandwidth is 2.12 GPix/second regardless of link bandwidth.
(8,192 × 4,320 × 60 / 1,000,000,000)
- HDCP: HDCP 2.x supported on HDMI inputs; HDCP 1.4 not supported.

K.8 HELIOS® - HDMI 2.1 Specifications

K 8.1 HDMI 2.1 Line Rates / Modes

FRL line rates: 6G, 8G, 10G, 12G	✓ Supported
TMDS Fallback	✓ Supported *
DSC	✗ Not Supported *

* TMDS fallback: Supported. When connected to HDMI 1.4/2.0 sources or displays that do not support FRL, the HDMI input operates in legacy TMDS mode at HDMI 2.0 bandwidth. Higher-bandwidth HDMI 2.1 formats require a successful FRL link.

** Since DSC is not supported all formats must operate uncompressed (only timings that fit within uncompressed FRL bandwidth are supported).

K 8.2 Other HDMI 2.1 Features

HDR Formats: HDR10, HLG	✓ Supported
Color Depth: 8-bit, 10-bit, 12-bit	✓ Supported
Dolby Vision	✗ Not Supported
eARC	✗ Not Supported
HDCP 2.3	✓ Supported
VRR (Variable Refresh Rate)	✗ Not Supported
HDMI Info Frame Parsing	✓ Supported
FRL Error Counters	✓ Supported
ALLM (Auto Low Latency Mode)	✗ Not Supported *

* HDMI ALLM is a TV-side feature that tells a display to switch into a low-processing “game” mode; HELIOS® already operates in a low-processing pipeline and gives you explicit control over latency through PLL/TLL.

NOTE: The HDMI 2.1 input does not support stitched rasters.

K.9 HELIOS® - ST 2110 Input Specifications

10G	
Item	Value
Total number of inputs	4
Supported bit depths	8, 10, 12 BPC
Supported color formats	4:4:4 or 4:2:2
Input maximum bandwidth	531 Megapixels per second, 4K@50Hz ea.
Redundancy	No
100G	
Item	Value
Total number of inputs	4
Supported bit depths	8, 10, 12 BPC
Supported color formats	4:4:4 or 4:2:2
A input maximum bandwidth*	2,124 Megapixels per second ,8k@60Hz
B/C/D inputs maximum bandwidth*	780 Megapixels per second, up to 4800 x 2700@60Hz ea. for a total of 8K@60Hz
Redundancy	Yes - ST 2022-7

*Total for all inputs (even if not selected in HELIOS®) must be less than or equal to 2,124 Megapixels per second.

K.10 HELIOS® - Supported SDI Input Formats

The following is a list of supported SDI formats:





Supported Resolutions for each SDI Input
1280 x 720
1920 x 1080
2048 x 1080
3840 x 2160
4096 x 2160

Supported Frame Rates
23.98 / 24
24.97 / 25
29.97 / 30
49.95 / 50
59.94 / 60

NOTES:

- The pixel format must be YCbCr 4:2:2
- All video signals must be Level A with the exception of 1080p 50/60 Hz can be Level B.
- Inputs can be combined using 2SI or square division. Square division is only supported across separate physical inputs (not within a single 12G link). Inputs combined with square division cannot be scaled.
- HELIOS® does not support interlaced or progressive segmented frame (PsF) signals.

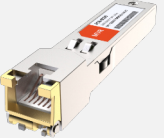
K.11 HELIOS® - Megapixel SFPs

SFP Type	Function	Part Number	Image
10Gb SFP+ 1270nm TX 1330nm RX 10km	HELIOS® Output	PCB-0008	
10Gb SFP+ 1330nm TX 1270nm RX 10km	Network Switch Input	PCB-0028	
1000 Base-T SFP 100m	HELIOS® Jr Output	PCB-0029	
12G SDI SFP+	SDI Input (BNC)	PCB-0006	

K.12 HELIOS® - Supported 100GB SFPs

FS.com SKU	SFP Type	Description
147611	QSFP28-ESR4-100G	Cisco QSFP-100G-ESR4-S Compatible 100GBASE-ESR4 QSFP28 850nm 300m OM4 DOM MTP/MPO-12 Parallel MMF Optical Transceiver Module, 4x 25G-ESR
48354	QSFP28-SR4-100G	Cisco QSFP-100G-SR4-S Compatible 100GBASE-SR4 QSFP28 850nm 100m OM4 DOM MPO-12 Parallel MMF Optical Transceiver Module, 4x 25G-SR
65219	QSFP28-IR4-100G	Cisco QSFP-100G-CWDM4-S Compatible 100GBASE-CWDM4 QSFP28 1310nm 2km OS2 DOM Duplex LC SMF Optical Transceiver Module

K.13 HELIOS® - Supported DAC (Direct Attached Cables)

FS.com SKU	SFP Type	Description
50174	Q28-AO01 ME	100G QSFP28 AOC 1m
65898	Q28-PC02	100G QSFP28 DAC 2m
148754	Q28-AC03	3m (10ft) Cisco Compatible 100G QSFP28 Active Direct Attach Copper Twinax Cable
50481	Q28-PC01	1m (3ft) Cisco QSFP-100G-CU1M Compatible 100G QSFP28 Passive Direct Attach Copper Twinax Cable
116122	Q28-PC015	1.5m (5ft) Cisco QSFP-100G-CU1.5M Compatible 100G QSFP28 Passive Direct Attach Copper Twinax Cable
116123	Q28-PC025	2.5m (8ft) Cisco QSFP-100G-CU2.5M Compatible 100G QSFP28 Passive Direct Attach Copper Twinax Cable
50482	Q28-PC03	3m (10ft) Cisco QSFP-100G-CU3M Compatible 100G QSFP28 Passive Direct Attach Copper Twinax Cable
50483	Q28-PC05	5m (16ft) Cisco QSFP-100G-CU5M Compatible 100G QSFP28 Passive Direct Attach Copper Twinax Cable

K.14 HELIOS® & Switch - Output Port Capacity (Pixels)

Bit Depth	10	10	10	12	12	12
Connection	Switch to Tiles	Switch to Tiles	HELIOS® to Switch	Switch to Tiles	Switch to Tiles	HELIOS® to Switch
Ethernet Speed (Gbps)	1	2.5*	10	1	2.5*	10
Video FPS						
24	1,237,000	3,094,000	8,075,000	1,031,000	2,578,000	8,075,000
25	1,187,000	2,968,000	8,075,000	989,000	2,473,000	8,075,000
30	985,000	2,464,000	8,075,000	821,000	2,053,000	8,075,000
48	608,000	1,520,000	6,082,000	506,000	1,267,000	5,068,000
50	583,000	1,457,000	5,830,000	485,000	1,214,000	4,858,000
60	482,000	1,205,000	4,823,000	401,000	1,004,000	4,019,000
120	230,000	576,000	2,306,000	192,000	480,000	1,921,000
144	188,000	471,000	1,886,000	157,000	393,000	1,572,000
180	146,000	366,000	1,466,000	122,000	305,000	1,222,000
200	129,000	324,000	1,299,000	108,000	270,000	1,082,000
240	104,000	261,000	1,047,000	87,000	218,000	872,000

* 2.5G connectivity is dependent on the tile design capabilities set by the tile manufacturer. Check tile specifications to ensure the tiles are 2.5G capable. Most tiles are only 1G capable.

NOTE: Regardless of frame rate or bit depth, the maximum pixels per HELIOS® output port is 8.5 million, and with all outputs combined, a maximum of 35 million pixels per HELIOS®.

K.15 HELIOS® - Fiber Out / Data to GSM4210P Network Switch

	720p (1280 x 720)	1080p (1920 x 1080)	UHD (3840 x 2160)	DCI 4K (4096 x 2160)	5K (5120 x 2880)	6K (6016 x 3384)	8K (7680 x 4320)	DCI 8K (8192 x 4320)
120 Hz								
444 12-bit	1 x 10Gb	2 x 10Gb	5 x 10Gb	6 x 10Gb	8 x 10Gb	No	No	No
444 10-bit	1 x 10Gb	2 x 10Gb	4 x 10Gb	5 x 10Gb	8 x 10Gb	8 x 10Gb	No	No
60 Hz								
444 12-bit	1 x 10Gb	1 x 10Gb	3 x 10Gb	3 x 10Gb	5 x 10Gb	5 x 10Gb	No	No
444 10-bit	1 x 10Gb	1 x 10Gb	3 x 10Gb	3 x 10Gb	4 x 10Gb	5 x 10Gb	8 x 10Gb	8 x 10Gb
30 Hz								
444 12-bit	1 x 10Gb	1 x 10Gb	2 x 10Gb	2 x 10Gb	3 x 10Gb	3 x 10Gb	5 x 10Gb	6 x 10Gb
444 10-bit	1 x 10Gb	1 x 10Gb	2 x 10Gb	2 x 10Gb	2 x 10Gb	3 x 10Gb	5 x 10Gb	5 x 10Gb

K.16 HELIOS® - Network Ports

HELIOS® runs a Linux build based on Alpine Linux. The following network ports and services are used by the system:

Network Ports	Notes
80 (TCP)	Main Web UI and Public API (HTTP)
443 (TCP)	Main Web UI, Public API (HTTPS)
443 (TCP Outbound)	General Megapixel Cloud connections
1900 (TCP+UDP)	Service Discovery (SSDP)
56066 (TCP Outbound)	Megapixel Cloud back-channeled remote connections
5353 (UDP)	Service Discovery (mDNS)
5568 (UDP)	Public API / Control (sACN)
56004 (TCP+UDP)	HELIOS® Stacking
ICMP	Network ping, etc.
5000 (TCP)	NMOS

K.17 HELIOS® - API

HELIOS® has a REST-like API. The API documentation is available on request. Please get in touch via our HELIOS® [support website](#). Select the API documentation button. Then, complete the form to download.

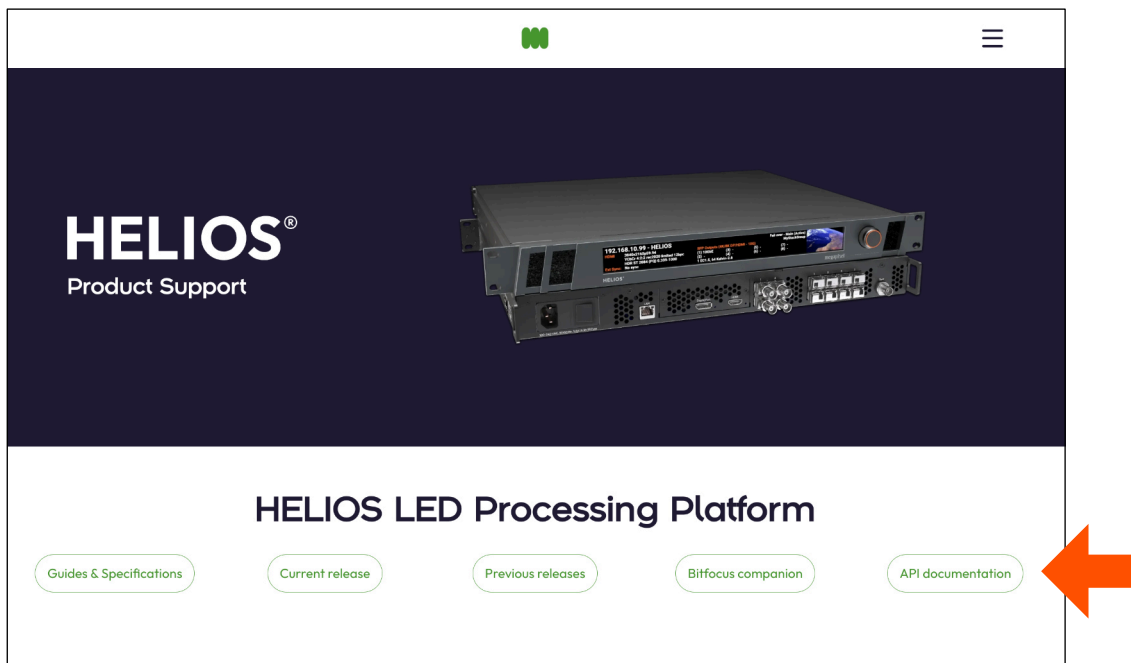











Figure 250: API documentation button

K.18 HELIOS® & Tile - Sensor Ranges

The table below provides the minimum/maximum range for key HELIOS® and tile sensors.

Sensor	Range	Alert Severity	
HELIOS® CPU Temp.	0°C - 80°C	Critical (Red)	
HELIOS® Case Temp.	0°C - 50°C	Critical (Red)	
HELIOS® Fan Speed	800 - 5,000 RPM	Warning (Yellow)	
HELIOS® SFP Temp.	0°C - 70°C	Error (Orange)	
HELIOS® 100GB VFMC Card	0°C - 85°C	Critical (Red)	
Tile CPU Temperature*	0°C - 85°C	Error (Orange)	
Tile LDM Temperature	0°C - 80°C	Error (Orange)	
Tile PHY Temperature	0°C - 90°C	Error (Orange)	
Tile Hub Temperature	0°C - 45°C	Error (Orange)	
Tile PHY db	3dBm - 12dBm	Error (Orange)	

*Tile CPU thermal crisis occurs at 125°C. Tiles at this temperature are blacked out until cooled to 85°C.

K.19 HELIOS® - Normal Voltage Ranges

Sensor	Range
SFP Voltage	3.2 - 3.4 V
SFP Current	2 - 44 mA
SFP Tx Power	-8.0 - 2.49 dBm
SFP Rx Power	-8.0 - 2.49 dBm

Sensor readings can be found on the **Devices** pane (examples marked with red rectangles below).

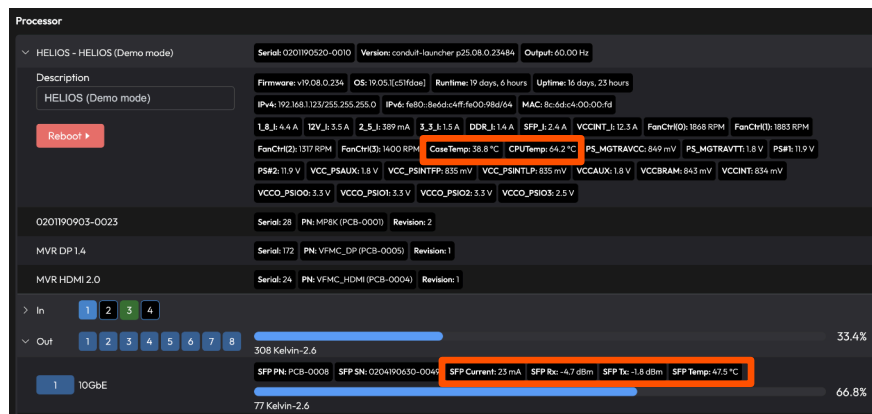

Figure 251: Devices pane sensor data

K.20 HELIOS® - Functions Tracked by Stacking

Below is a comprehensive list of features that the HELIOS® Stacking feature tracks when enabled. For more information on how to use Stacking see the [Processor Stacking](#) section.

■ Global

- Blackout
- Freeze
- Lock Controls
- Image Settings
 - Brightness
 - Gamma
 - Color Temperatures + Duv
- Video Patterns
 - Test pattern settings (Enable, Color, Motion, Type)
 - Show Still toggle, but not the selected still
 - Show Tile Topology

■ Mapping

- Canvas Lock
- Tile Position & Rotation
- Positioning Tools (CAD style selection)
- GhostFrame® bypass
- Group assignment
- Group settings (all, incl. mask media selection)

■ Seams

- Tile Seams (Show seams)

■ Input

- HDCP allow
- Input adjustments (all sliders + range/standard overrides)
- Aspect ratio
- EOTF adjustments
- NanoSync® (Enable, Delay, No input freq.)
- Output window (Canvas repeat)

■ Output

- Curves (Enable + Curve points)
- Adjustments (Enable, Lift, Gamma, Gain, Offset, Saturation, Legacy)
- Display gamut
 - Gamut type
 - Custom gamut points
- Calibration
 - Bypass calibration
 - LDM level correction
 - Clip to achievable
- Display bit depth
- Light science
- Latency (TLL + PLL + frame delay)
- Output adjustments (R/G/B, Black Clipping, Gamma offset, Limit to lowest)

■ Camera/GhostFrame®

- Enable
- Video streams
- Chroma colors
- Slices with gains
- Advanced timings (Active, Refresh, Overclock)

■ Settings

- Interface (Dark mode, Language)
- Tiles (Identify behavior, Fan control, Low power mode)
- Redundancy (Mode, backup test pattern, Offline on input failure)

NOTES:

- Inputs are per named input. Processors in a stack must have identically named inputs. As an example, if 'HDMI1' is used as a name it will not match 'HDMI'.
- The widest/achievable gamut type is synchronized, the actual achievable points are not. Actual achievable points are dependent on the tiles connected to the processor.

K.21 HELIOS® - Shipping Info.

HELIOS® LED Processing Platform w/ 100G SMPTE ST 2110 Input KIT-0050	5.6 kg 12.4lb
HELIOS® LED Processing Platform w/ HDMI & DP Input KIT-0008	5.3 kg 11.7 lb
HELIOS® LED Processing Platform w/ Dual DP Input KIT-0009	5.3 kg 11.7 lb
HELIOS® LED Processing Platform w/ Dual HDMI Input KIT-0010	5.3 kg 11.7 lb

Each HELIOS® box contains:

- HELIOS®
- Power cord (North American, NEMA 5-15P)
- Ethernet cable (5ft)
- Rack mount screws
- Quickstart guide

K.22 HELIOS® - Dimensions

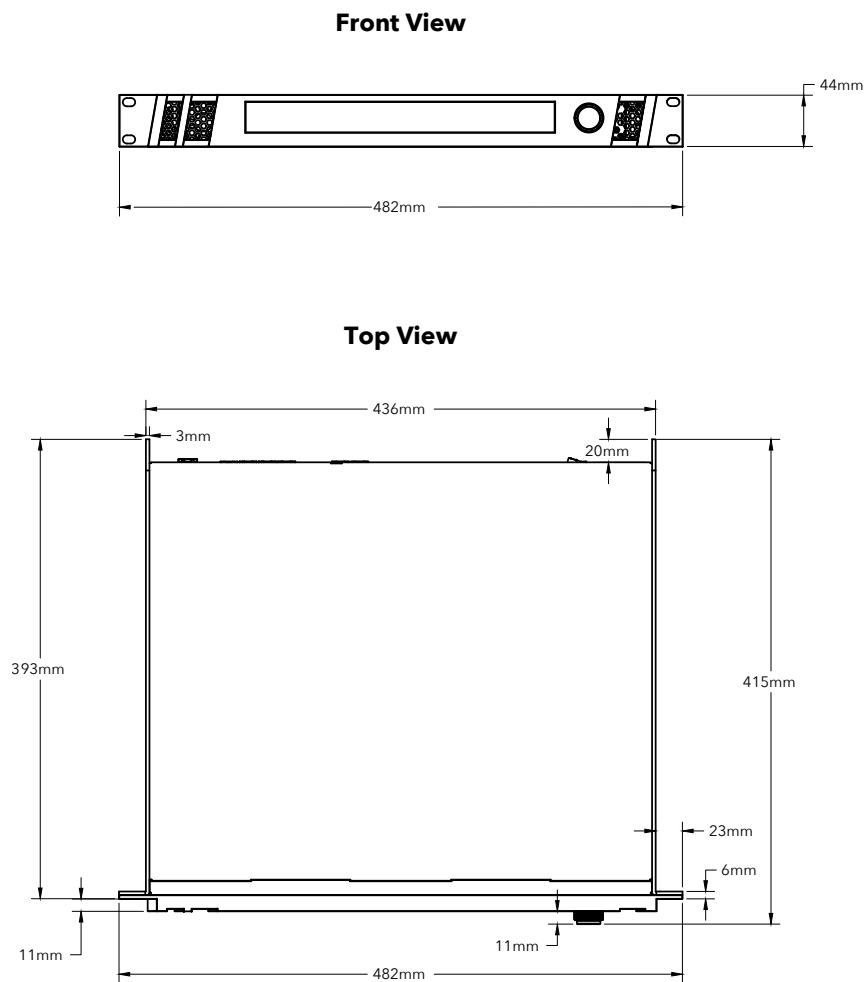

Figure 252: HELIOS® dimensions

L - Glossary

This glossary defines technical terms, acronyms, and proprietary names used throughout the HELIOS® User Guide. Entries are grouped by category and sorted alphabetically within each group.

L.1 Megapixel Proprietary Terms

Term	Definition
GhostFrame®	<p>A Megapixel technology for virtual production and motion picture applications that interleaves multiple sub-frame images within a single video frame period. GhostFrame® takes advantage of the high refresh rates of LED displays to deliver separate content streams simultaneously — one optimized for camera capture and one for human vision. Requires a GhostFrame® license and compatible LED tiles.</p> <p>See also: Sub-frame Slice Gains; Virtual Production</p>
LDM (LED Display Module)	<p>The front-facing modular panel of an LED tile, populated with the display LEDs. One or more LDMs make up the visible surface of a tile. LDMs contain the LED elements and connect to the tile's Hub PCB. LDM seam and configuration information is stored on the tile itself, not on the HELIOS® processor.</p> <p>See also: Hub PCB; PX1 Receiver Card</p>
LightScience®	<p>A proprietary HELIOS® algorithm that improves the reproduction of low-light levels and shadow detail on LED displays. LightScience® expands the effective bit depth of each tile to 21 or up to 32 bits per color channel, enhancing gradation in near-black regions that standard bit depths cannot resolve. Enabled in the Output pane.</p>
NanoSync®	<p>Megapixel's proprietary synchronization system that aligns the actual light output of LED tiles to the video source signal within 1/4 microsecond (250 nanoseconds). NanoSync® can lock to the inbound video signal frequency or to an external clock source (analog genlock via rear BNC, or PTP). Required for redundant systems and camera-synchronized virtual production setups.</p> <p>See also: PTP; Genlock</p>
PXL	<p>The proprietary display protocol developed by Megapixel for communication between the HELIOS® processor and connected LED tiles. Tiles must be equipped with a PXL-compatible receiver card (such as the PX1) to receive and decode HELIOS® video streams and tile management messages.</p> <p>See also: PX1 Receiver Card</p>
PX1 Receiver Card	<p>A PXL-compatible receiver card installed in LED tiles that enables communication with the HELIOS® processor. The PX1 decodes HELIOS® video streams and tile management messages, and reports onboard sensor data (fan, CPU, PSU) back to the processor.</p> <p>See also: PXL; LDM</p>
Seamless Loop™	<p>Megapixel's redundancy architecture for LED tile data distribution. In a Seamless Loop™ configuration, tiles receive duplicate data so that a single link failure does not interrupt the display. Variants include HELIOS® Jr. redundancy (no switches), Tile Link Redundancy (bidirectional data from switch to tiles), and Switch Redundancy (multiple fiber ports feeding redundant switches).</p> <p>See also: Redundancy; Data Redundancy</p>
VFMC (Video Format and Media Card)	<p>The removable input card module housed in the center of the HELIOS® front panel. VFMC cards provide the video inputs for the processor. The card is field-replaceable, allowing input type changes without replacing the full unit.</p> <p>See also: HDMI; DisplayPort</p>

L.2 Video & Color Standards

Term	Definition
Bit Depth	<p>The number of bits used to represent each color channel in a video signal. Higher bit depth allows more gradations between colors, reducing visible banding. HDR workflows require a minimum of 10-bit; HELIOS® recommends 12-bit where bandwidth allows. Consumer sources may default to 8-bit, which is insufficient for HDR.</p> <p>See also: HDR; Display Bit Depth</p>
CIE 1931 Chromaticity	<p>A standardized color space defined by the International Commission on Illumination (CIE) in 1931, represented as a 2D chart using x and y coordinates. HELIOS® uses CIE 1931 chromaticity coordinates to define and display gamut targets in the Display Gamut accordion. The CIE chart shows tile capabilities, achievable gamut, and any out-of-range targets.</p> <p>See also: Display Gamut; Rec.2020; Color Space</p>
Chroma Subsampling	<p>A method of encoding color information at a lower resolution than luminance. Expressed as a ratio (4:4:4, 4:2:2, 4:2:0). 4:4:4 preserves full color detail; 4:2:2 reduces horizontal color resolution by half; 4:2:0 reduces both horizontal and vertical color resolution. HELIOS® does not fully support 4:2:0 — a 4:2:0 input will display as black and white. Set input sources to 4:2:2 or 4:4:4.</p> <p>See also: Color Space; HDR</p>
Color Space	<p>The defined range of colors that a signal, display, or workflow can represent. Common color spaces in HELIOS® workflows include Rec.709 (standard HD video), Rec.2020 (HDR signal definition, wide gamut), and P3 (common HDR content color space, a subset of Rec.2020). Mismatched color spaces between content and display produce desaturated or incorrect color.</p> <p>See also: Rec.2020; Display Gamut; HDR</p>
Delta E (ΔE)	<p>A numerical measure of perceptual color difference between two color values. A Delta E below 1.0 is imperceptible to the human eye. Values above 3.0 are clearly visible. Used to assess calibration accuracy and consistency across LED panels. Requires additional equipment such as a colorimeter.</p> <p>See also: Calibration; Tile Calibration Report</p>
Display Gamut	<p>The range of colors a display system is capable of reproducing, defined using CIE 1931 chromaticity coordinates. In HELIOS®, the Display Gamut accordion allows setting color targets (e.g., Rec.2020, P3) and comparing the Target (configured) values against the Actual (tile-measured) values. Wide gamut capability is required for HDR output.</p> <p>See also: CIE 1931 Chromaticity; Rec.2020; HDR</p>
EOTF (Electro-Optical Transfer Function)	<p>The mathematical function that defines how encoded digital signal values are converted into light output (luminance) on a display. HELIOS® supports SDR (gamma 2.4), SDR Preserve Details (sRGB), PQ (SMPTE ST 2084 for HDR10), and HLG. The EOTF must match the transfer function used during content mastering.</p> <p>See also: PQ; HLG; HDR; Tone Mapping</p>
HDR (High Dynamic Range)	<p>A video standard that extends the range of luminance and color beyond standard dynamic range (SDR). HDR requires consistent handling across the full pipeline: HDR-mastered content, a supporting playback device, correct signal transport, an HDR-capable processor (HELIOS®), and HDR-capable display tiles. HELIOS® supports HDR10 (PQ-based) and HLG. HDR requires a minimum of 10-bit color and wide gamut tile capability.</p> <p>See also: EOTF; PQ; HLG; Rec.2020; MaxCLL; MaxFALL</p>
HLG (Hybrid Log-Gamma)	<p>A broadcast-oriented HDR transfer function that is backward-compatible with SDR displays. HLG does not carry absolute luminance metadata — it uses display maximum luminance rather than content light level information. Supported by HELIOS® alongside PQ.</p> <p>See also: EOTF; PQ; HDR</p>

L.2 Video & Color Standards

Term	Definition
LUT (Look-Up Table)	<p>A mathematical table used to transform color values from one state to another. LUTs are used in color grading, calibration, and display management pipelines. Unintended LUTs applied inside media servers or playback systems are a common source of HDR color errors. HELIOS® supports LUT-based color management through its calibration system.</p> <p>See also: Color Space; EOTF; Calibration</p>
MaxCLL (Maximum Content Light Level)	<p>An HDR10 static metadata value specifying the highest single-pixel luminance value anywhere in the content, expressed in nits. HELIOS® reads MaxCLL from the inbound signal to inform tone mapping and roll-off decisions. If MaxCLL is absent or zero, HELIOS® assumes content is mastered for the display's maximum luminance.</p> <p>See also: MaxFALL; HDR; PQ; Tone Mapping</p>
MaxFALL (Maximum Frame Average Light Level)	<p>An HDR10 static metadata value specifying the highest average luminance across all pixels in any single frame of the content, expressed in nits. Used alongside MaxCLL to characterize the brightness envelope of HDR content and inform display rendering decisions.</p> <p>See also: MaxCLL; HDR; PQ</p>
Nits	<p>A unit of luminance equal to one candela per square meter (cd/m²). Used to describe the brightness of content mastering targets and display capabilities. HDR10 content is typically mastered to 1,000 nits; the PQ transfer function is defined up to 10,000 nits. HELIOS® reports display maximum luminance and content maximum luminance in nits.</p> <p>See also: HDR; PQ; EOTF</p>
PQ (Perceptual Quantizer)	<p>The SMPTE ST 2084 transfer function used for HDR10 content. PQ maps encoded values to absolute luminance levels (defined up to 10,000 nits), making it display-agnostic. PQ content carries MaxCLL and MaxFALL metadata. HELIOS® reads PQ content and maps it to the display's actual luminance range using roll-off curves when a mismatch exists.</p> <p>See also: EOTF; HDR; MaxCLL; MaxFALL; SMPTE ST 2110</p>
Rec.2020 (BT.2020)	<p>The ITU-R BT.2020 wide color gamut standard used as the signal color space definition for HDR content. Rec.2020 encompasses a wider gamut than Rec.709 or P3. Most LED displays reproduce a P3 subset of Rec.2020. HELIOS® uses Rec.2020 as its default Auto gamut target and references Rec.2020 coordinates on the CIE gamut chart.</p> <p>See also: Color Space; Display Gamut; HDR; CIE 1931 Chromaticity</p>
SDR (Standard Dynamic Range)	<p>The conventional video standard using a gamma-based transfer function (typically gamma 2.4 or sRGB), a Rec.709 color space, and luminance levels referenced to 100 nits. HELIOS® supports SDR alongside HDR and can operate with mixed SDR/HDR inputs. The SDR max 100 nits toggle preserves correct SDR rendering when HELIOS® is operating at higher brightness levels.</p> <p>See also: HDR; EOTF; Rec.2020</p>
Signal Range (Full vs. Legal)	<p>Defines the quantization range used to encode video levels. Legal (Limited) range uses values 16–235 for luma, where 16 = black and 235 = white. Full range uses 0–255. HELIOS® must be configured to match the encoding of the source signal via the Color Range Override in the Input pane. A mismatch causes crushed blacks or clipped whites.</p> <p>See also: Color Range Override; EOTF</p>
Tone Mapping	<p>The process of remapping brightness values from the content mastering range to the display's actual capability. When content peak luminance exceeds display peak luminance, HELIOS® introduces a roll-off curve to preserve highlight detail. Tone mapping should occur at only one stage in the pipeline — applying it at both the media server and HELIOS® results in compounded errors.</p> <p>See also: EOTF; PQ; HDR; MaxCLL</p>

L.3 Networking & Protocols

Term	Definition
DHCP (Dynamic Host Configuration Protocol)	<p>A network protocol that automatically assigns IP addresses to devices on a network. HELIOS® supports DHCP for automatic IP assignment. For fixed installations, a static IP address is recommended to ensure reliable access to the HELIOS® web UI.</p> <p>See also: IP Addressing; Networking</p>
DNS-SD (DNS Service Discovery)	<p>A protocol that enables automatic discovery of network services using standard DNS queries. HELIOS® uses DNS-SD alongside SSDP for network device discovery. Can be toggled on or off under Settings > Processor Settings > Networking.</p> <p>See also: SSDP; mDNS; Networking</p>
EDID (Extended Display Identification Data)	<p>A metadata standard that allows a display device to communicate its capabilities (supported resolutions, refresh rates, color formats) to a connected source. HELIOS® uses EDID to inform media playback devices of the capabilities of its DisplayPort and HDMI input cards. Custom EDID files can be uploaded when non-standard resolutions or frame rates are required.</p> <p>See also: HDMI; DisplayPort; VFMC</p>
HDCP (High-bandwidth Digital Content Protection)	<p>A copy protection standard applied to HDMI signals carrying DRM-protected content. HELIOS® HDMI inputs support HDCP 2.x — meaning any version in the HDCP 2 family (2.2, 2.3, etc.). HDCP 2.3 is recommended where the source device supports it, as it includes security improvements over earlier revisions, but HDCP 2.2 is sufficient for normal operation. HDCP 1.4 is not supported. A separate HDCP license is required for HELIOS® to process HDCP-protected content.</p> <p>See also: HDMI; EDID; Licensing</p>
ICMP (Internet Control Message Protocol)	<p>A network protocol used for diagnostic and control functions, including the ping command used to test network connectivity. HELIOS® uses ICMP for network ping operations.</p> <p>See also: Networking</p>
LLDP (Link Layer Discovery Protocol)	<p>A vendor-neutral network protocol that allows devices to advertise their identity and capabilities to neighboring devices on a local network. Used in HELIOS® systems for switch and device discovery on the network topology.</p> <p>See also: Networking; Network Switch</p>
mDNS (Multicast DNS)	<p>A protocol that resolves hostnames to IP addresses within a local network without a dedicated DNS server, using multicast UDP on port 5353. HELIOS® uses mDNS for service discovery on local networks.</p> <p>See also: DNS-SD; SSDP; Networking</p>
NMOS (Networked Media Open Specifications)	<p>A suite of open specifications for IP-connected audio and video devices, enabling automatic device discovery, registration, and connection management. HELIOS® implements NMOS to support SMPTE ST 2110 workflows. Key components include the NMOS Registry (centralized registration), NMOS Controller (connection management), and NMOS Node (each device on the network).</p> <p>See also: SMPTE ST 2110; SDP; PTP</p>
PTP (Precision Time Protocol)	<p>IEEE 1588 — a network protocol for synchronizing clocks across devices on a local network to sub-microsecond accuracy. Used in SMPTE ST 2110 environments to provide a shared timing reference for video streams and for HELIOS® NanoSync® synchronization. A PTP Generator device provides sync through the network switch to connected devices.</p> <p>See also: NanoSync®; SMPTE ST 2110; NMOS</p>
sACN (Streaming ACN / ANSI E1.31)	<p>A streaming protocol based on the ANSI E1.31 standard, used for remote control of lighting and display systems over IP networks. HELIOS® supports sACN for remote control of group and processor parameters including intensity, color, and brightness. When sACN is active, controlled functions are locked in the GUI and cannot be adjusted manually.</p> <p>See also: Networking; Tile Groups</p>

L.3 Networking & Protocols

Term	Definition
SDP (Session Description Protocol)	<p>A text-based format (IETF RFC 4566) that describes multimedia session parameters including stream source addresses, payload types, clock rates, and format-specific attributes. HELIOS® requires an SDP record to locate and connect to a SMPTE ST 2110 video stream on the network. SDP records can be entered manually or managed automatically via NMOS.</p> <p>See also: SMPTE ST 2110; NMOS; ST 2110 Input</p>
SFP / SFP+ (Small Form-factor Pluggable)	<p>A compact, hot-swappable transceiver module used for network data and video signal transmission. HELIOS® uses SFP+ modules for 10G fiber outputs to display tiles and for 12G SDI video inputs. Standard licenses support 1G copper SFP modules; fiber SFP+ modules require a Standard or higher license.</p> <p>See also: Licensing; Fiber Troubleshooting</p>
RTP (Real-time Transport Protocol)	<p>A network protocol for delivering audio and video over IP networks. RTP breaks a media stream into individually addressed packets called datagrams, each stamped with sequence and timing information to allow the receiver to reassemble and synchronize the content. SMPTE ST 2110 uses RTP as its transport layer.</p> <p>See also: SMPTE ST 2110; SMPTE ST 2022-7; SDP</p>
SMPTE ST 2022-7	<p>A SMPTE standard for seamless reconstruction of RTP datagrams. ST 2022-7 defines how a receiver can reconstruct a single output stream from two redundant streams sent over separate network paths, reconstructing on a packet-by-packet basis. HELIOS® implements ST 2022-7 on its 100G input, providing automatic failover between primary and secondary ST 2110 streams without user intervention.</p> <p>See also: SMPTE ST 2110; SDP; RTP</p>
SMPTE ST 2110	<p>A suite of standards developed by the Society of Motion Picture and Television Engineers (SMPTE) for professional media over IP networks. ST 2110 defines the transport of uncompressed video, audio, and ancillary data as separate IP streams. HELIOS® supports ST 2110 input via a 100G VFMC card. ST 2110 is the preferred transport for HDR workflows due to its reliable metadata handling.</p> <p>See also: SDP; NMOS; PTP; HDR</p>
SSDP (Simple Service Discovery Protocol)	<p>A network protocol used for advertisement and discovery of network services and devices without dedicated configuration servers. HELIOS® uses SSDP on port 1900 for device discovery on the local network. Can be toggled on or off under Settings > Processor Settings > Networking.</p> <p>See also: mDNS; DNS-SD; Networking</p>